

ARGENTINE
STANDARD

IRAM
2063*

Third edition
2001-12-28

Modification N°1:2003 is included in this printing

<http://www.china-gauges.com/>
Bipolar electrical ungrounded plug, for 10 A, 250 V of alternating current, for household and similar uses

Corresponds to review of IRAM standard 2063:1982.

Numeric reference:
IRAM 2063:2001

IRAM 2063:2001

Preface

A non-profit civil association, the Argentine Institute of Standardization IRAM (in Spanish, Instituto Argentino de Normalización), in its capacity of Standardization Organ of Argentina, is concerned with the establishment of technical norms - unlimited in whichever the field they cover- and fosters the application of standardization as the basis of quality by promoting product certification procedures and quality systems in companies to provide for consumer satisfaction.

IRAM is Argentina's representative at the International Organization for Standardization (ISO), at the Pan American Commission for Technical Standards COPANT (in Spanish Comisión Panamericana de Normas Técnicas) and at the Standardization Committee for MERCOSUR CMN (in Spanish, Comité MERCOSUR de Normalización).

This IRAM standard emerges from the technical consensus reached among the several parties involved, which, through their incumbent representatives, have acted in the corresponding Standard Study Organs.

This corresponds to the review of IRAM standard 2063:1982.

Index

	Page
1. GOAL AND SCOPE.....	4
2. REFERENCE STANDARDS.....	4
3. GLOSSARY OF TERMS	4
4. GENERAL TERMS.....	5
5. INSPECTION AND RECEPTION.....	8
6. TEST METHODS.....	8
Annex A (Informative) Bibliography.....	13
Annex B (Informative) Members of the study organisms.....	14

<http://www.china-gauges.com/>

Bipolar electrical ungrounded plug, for 10 A, 250 V of alternating current, for household and similar uses

1 GOAL AND SCOPE

1.1 Establish the requirements and tests bipolar electrical plugs without ground connection, for 10 A, 250 V alternating current, for household and similar purposes, shall comply with so as to be used in type 2 insulation devices.

1.2 This does not include plugs meant to be used in explosive environments or with corrosive gases, neither in ship on board facilities.

2 REFERENCE STANDARDS

The following norms contain provisions which, when being quoted in the texts, constitute a requirement of this IRAM standard. The issues stated were valid at the time of this publication. As any other standard, it is subject to review and for those who make agreements based on this standard, it is advisable to analyse whether the use of more recent issues of the following standards is convenient. The IRAM holds information on the currently valid standards.

IRAM 15:1973 – Inspections for attributes. Single, double, and multiple sample with rejection.

IRAM 2006:1983 – Outlets, plugs and sockets. General requirements.

IRAM 2007:1995 – Manual electrical switches for household and similar use.

IRAM 2022:1988 – Electrical conductors for insulated wires.

IRAM 2158:1992 – Insulated flexible wires with vinyl polychloride (PVC). For nominal voltage of up to 300:19500 V. Requirements and tests.

IRAM 2339:1991 – Solid electrical insulating materials. Method to determine the resistance indexes and the electrical steering test under humid conditions.

NM 01:00 IEC 60228:2000* - Conductors for insulated wires.

NM 01:00-IEC 60227-5:2000* - Vinyl polychloride (PVC) insulated wires for nominal voltage of up to 450/750 V, inclusive. Part 5: flexible cords and wires.

IEC 60884-1 – Plugs and sockets for household or similar use. Part 1: General requirements.

(*) Projects for MERCOSUR Norm NM 01:00-IEC 60228 and NM 01:00 IEC 60227-5 are under study, which once approved will replace the corresponding IRAM standards, respectively.

3 GLOSSARY OF TERMS

3.1. plug. Movable accessory with contact pins, which is used to temporarily connect a consuming device to a fix or mobile outlet.

3.2. nominal voltage. Network voltage for which the plug has been manufactured, according to the manufacturer's specification.

3.3. nominal current. Permanent maximum current for which the plug has been manufactured, according to the manufacturer's specification (10 A).

3.4. dismantlable plug: plug built in such a way that the flexible wire can be replaced.

3.5. non-dismountable plug: plug built in such a way that it makes a whole unit with the flexible wire, after connection and assembly by the manufacturer.

3.6. injected plug: non-dismountable plug which is completed by covering the pre-assembled component with the flexible wire finishings with insulating material.

3.7. finishing: insulated or not connection element meant to prevent the reconnection of the supplying wire.

4. GENERAL TERMS

4.1. General features. The plugs will comply with all applying terms specified in IRAM 2006.

4.2 Standardized values

4.2.1 The standardized value for the nominal voltage will be 250 V efficacious.

4.2.2 The standardized value for the nominal current will be 10 A efficacious.

4.3 Conductor. For compound plugs, the terminals will enable the connection of flexible conductors with a section from 0.5 mm² to 1.5mm²; the fastening device will fit the external diameters of the wire between 6 mm and 8 mm, inclusive. (see IRAM 2022 and IRAM 2158)*.

Projects for MERCOSUR Norm NM 01:00-IEC 60228 and NM 01:00 IEC 60227-5 are under study, which once approved will replace the corresponding IRAM standards, respectively.

The tests for the fastening device will be performed according to standard IEC 60884-1, point 23.2, with 2 x 0.5mm² wires.

NOTE: In case wires with special shapes are used, the features of the fastening device will be previously agreed on, having to comply with all applicable tests specified in this standard.

4.4 Plug shape. The plug will have a shape suitable to allow its easy manual plugging and unplugging, so that it can be plugged or unplugged without exposing the conductor to any kind of strain. The useful length of the plugging and unplugging grip will be no less than 15 mm.

4.5 Dimensions

4.5.1 The plug dimensions, specified according to 6.2 to 6.2.6, inclusive, will be the ones shown on table 1 and figure 1.

Table 1 – Plug dimensions

Plug	a	b	E	$\frac{g}{g}$
10 A	6.25	7.92	155 ± 0.07	18.2 ± 0.2

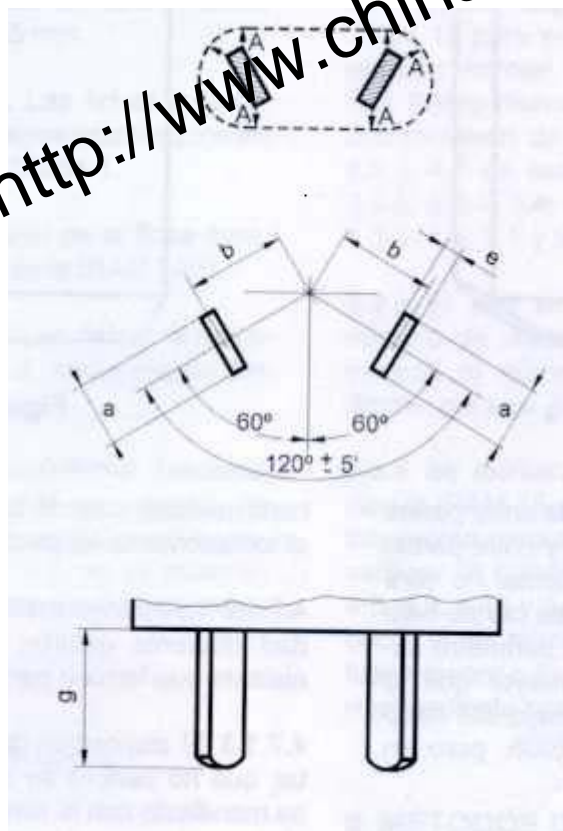

References

Dimensions in mm

A: 8 mm (min.)

The broken line only delimits the construction minimum value

Figure 1 – Plug dimensions

4.5.2. Pin endings: the connection pin endings will be shaped in the appropriate way according to figure 2a or figure 2b.

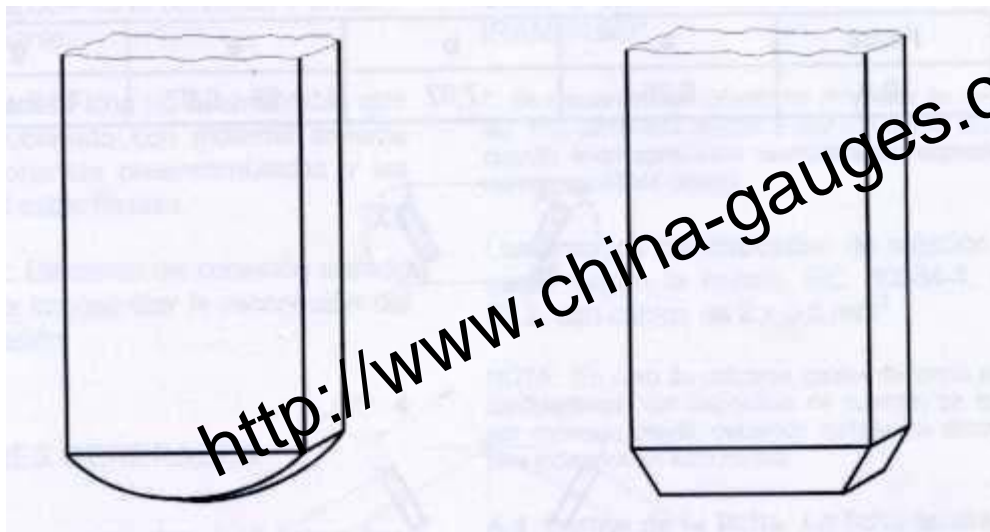

Figure 2 a

Figure 2 b

4.6 Insulating distance. The distance between the parts under voltage with a different polarity and between the metallic parts not conducting current will not be lower than 3 mm. The distance between parts under voltage with a different polarity and the external perimeter of the plug will be equal or higher than the necessary one to comply with the finger test trial specified in IRAM 2006, but in no case it will be lower than 8 mm.

4.7 Construction

4.7.1 Dismountable plugs

4.7.1.1 The constituting parts of the plug will be tightly fastened, so that it becomes impossible to dismantle the plug, without

the use of tools, when the plug is connected into its corresponding outlet.

4.7.1.2 The internal metallic parts of different polarity will be separated by insulating material which make an integral part of the plug.

4.7.1.3 The fastening device of the wire will be in such way that cannot pierce its insulation and whose action manifests itself with the assembled plug.

4.7.2 Layout and polarity

4.7.2.1 The layout and polarity of the pins for any type of plug, as seen from the pins, will be the one shown in figure 3.

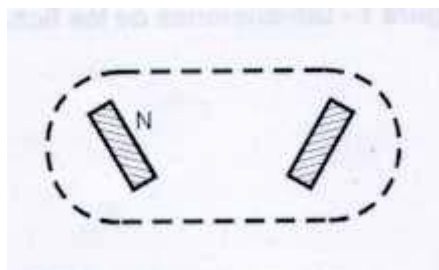

Figure 3

Layout and polarity of the plug, as seen from the pins
The broken line does not delimit the construction limits

4.7.2.2 The neutral terminal will be identified with the symbol N.

4.7.2.3 Insertion face. The insertion face of the plugs shall not present any protruding part other than the pin, when the plug has one of its conductors and is assembled for normal use, except the markings on relief with a maximum height of 0.5 mm.

4.8 **Mechanic resistance.** The injected plugs shall comply with the tests established in 24.4, 24.5 and 24.10 of the IEC 60884-1.

4.9 **Inflamability.** The plug material will comply with all that has been established in 23.1 of IRAM 2007.

4.10 **Heat resistance.** The plugs tested according to 6.3 will be resistant to heat.

4.11 **Superficial dielectric rigidity (steering).** For plugs with a protection rate higher than IP X1, once the test specified in 6.4 has been performed, no discharge between the electrodes shall take place before 50 drops fall.

5. INSPECTION AND RECEPTION

5.1 Type of test

5.1.1 Six specimens of the same type will undergo the tests specified in chapters 4 and 6. The non-destructive tests will be performed on 3 specimens and the destructive ones on the other 3. If necessary, additional specimens will be used.

5.1.2 The type will be considered as approved if all specimens comply with all the requirements of this standard.

IRAM 2063:2001

5.2. Lot tests

5.2.1. All units with the same model and having the features of one complying with 5.1 will be grouped in lots.

5.2.2 On these lots as many specimens as specified by IRAM 15 for the simple sampling, normal inspection and special inspection level S-3 will be taken. On these specimens the compliance to conditions 4.2, 4.3, 4.5, 4.6 and 4.7 of this standard, and 3.1.1., 3.1.3, 3.2.1, 3.2.3, 3.3.1, 3.4, 4.2.2, 4.2.3, 4.2.4, 4.3.1, 4.3.2, 4.3.3, 4.4, 5.1 and 5.2 of IRAM 2006 will be verified.

5.2.3 The lot will be considered as approved if the number of defective units is lower or equal to the corresponding acceptance number, for an AQL of 2.5%.

5.2.4 As many specimens as specified by IRAM 15 for the simple sampling, normal inspection and special inspection level S-1 will be taken so as to verify the compliance to what is specified in 4.8, 4.9, 4.10 and 4.11. The lot will be considered as approved if the number of defective units is lower or equal to the corresponding acceptance number, for an AQL = 4.0%.

6 Test methods

6.1 Test conditions. The tests specified in this standard will be performed, unless otherwise stated, with the plug in the conditions for use, that is, with the corresponding conductors connected to the respective terminals.

6.2 Dimensions

6.2.1 The width, length and thickness of the pins are verified by means of a combined calibrator “fits” and “doesn’t fit” of the measures established in table 2 and fig. 4

Table 2

Dimension (mm)	POLES		
	a	e	
Fits Side	6.36 ^{+0.01} ₀	1.63 ^{+0.01} ₀	8.4 ± 0.01
Doesn't fit Side	6.14 ⁰ _{-0.01}	1.47 ⁰ _{-0.01}	9.10 ± 0.5

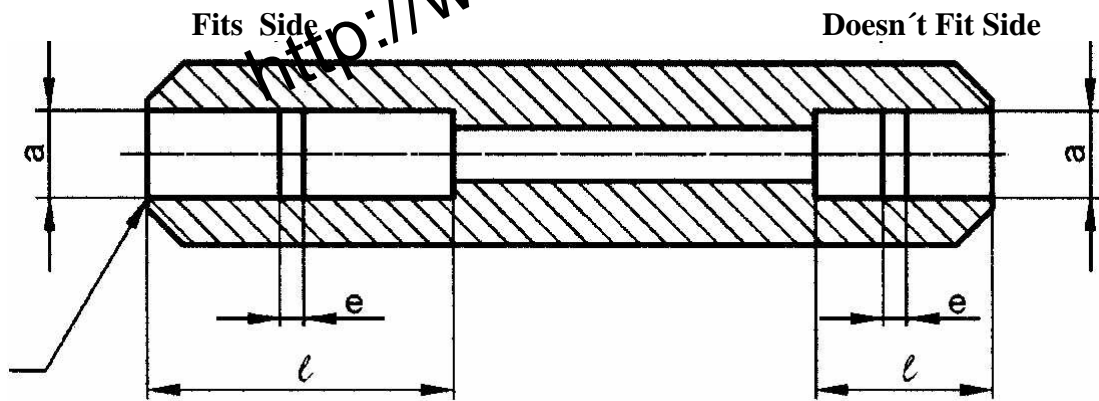

Figure 4 – “Fits” and “Doesn’t fit” calibrator

6.2.2 The verification with the “Fits” calibrator is made introducing this calibrator, without forcing it, into each of the contact pins, the S area will make contact with the external part of the plug. Then a calibrator with a thickness of 0.5 deep is placed at the bottom of the calibrator and, introducing the pins in the same way as it was described, the area S of the “fits” calibrator shall not make contact with the external part of the plug. The contact pins will not penetrate the “doesn’t fit” calibrator in any position.

6.2.3 The pin layout is verified by using the “fits” calibrator having the measures specified in table 3 and figure 5.

6.2.4 For the tests specified in IRAM 2006, the standard outlet of plain frontal area is used, whose measures are specified on table 3 and figure 5, the contact layers will be made of phosphorous bornze, with an adequate elasticity and the connections will be built with copper wires having a 1.8 mm diameter.

Table 3 – Measures for the standard outlet to verify the pins (mm)

Standard Outlet	A	b	c	d	s	g_{min}
10 A	7 ± 0.05	7.92 ± 0.025	7.92 ± 0.025	10.3 ± 0.025	2.2 ± 0.05	18.4

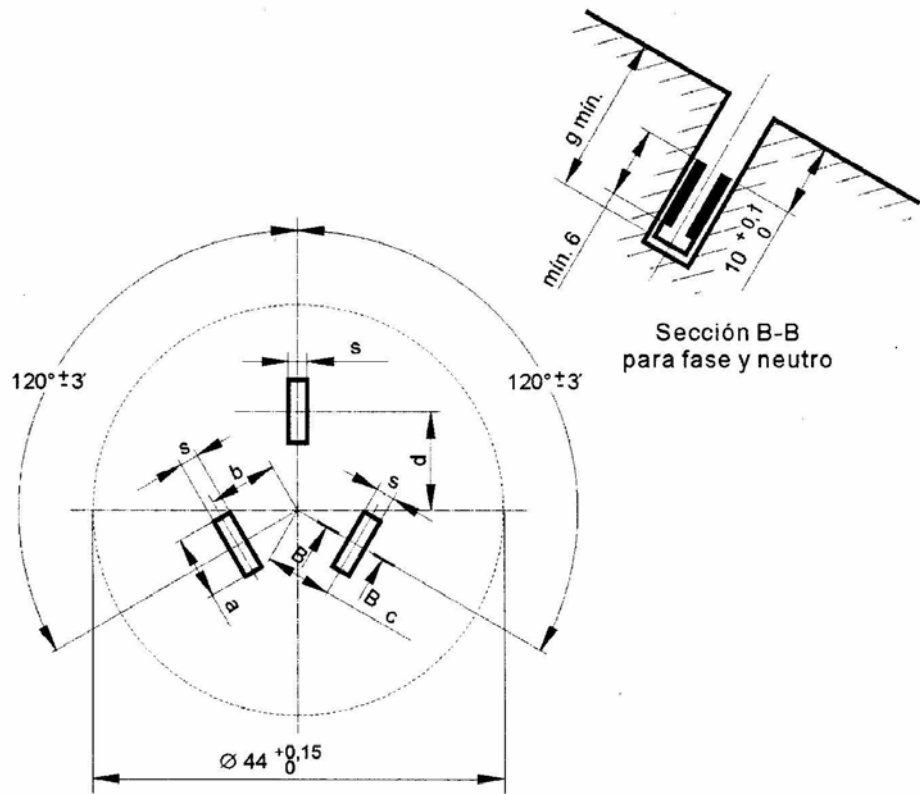

Figure 5 – Standard outlet for bipolar plugs with or without ground connection

(Where *Sección B-B para fase y neutro* = Section B-B for phase and neutral)

6.2.5 The standard outlet is verified by means of a calibrator having the measures specified in table 4 and figure 6. Each contact layer will resist the Mnd mass without the pin detaching and, with Md mass the pin will detach before 5 s.

6.2.6 The measurements for which calibrators are not recommended are verified with measuring instruments which allow reading 0.01 mm.

6.3 Heat resistance

The plugs will be resistant to heat.

The compliance is verified carrying out the tests specified in chapter 25 of the IEC 60884-1:1994

NOTE: according to the IECEE interpretation, the exception made in the IEC 60884-1, chapter 25, item b) for those compounds with natural or synthetic rubber or a mixture of both shall also apply to those made of PVC.

Table 4 – Calibrator measurement for the verification of the standard outlet

Type	a (mm)	e (mm)	L (mm)	Md (kg)	Mnd (kg)
10 A	6.25 ± 0.02	1.55 ± 0.02	Poles 18.2 ± 0.2	1.5	0.5

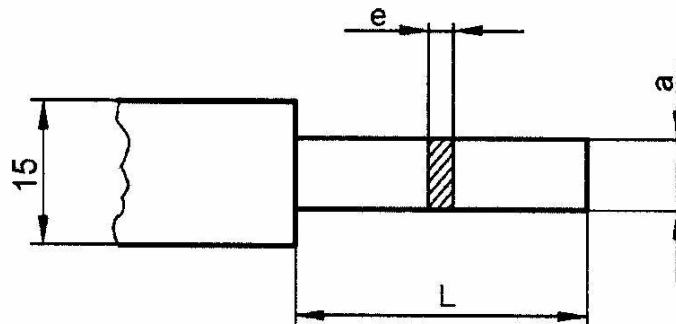

Figure 6 – Calibrator for the verification of the standard outlet

6.4 Superficial dielectric rigidity (steering)

6.4.1 The test requires the use of two platinum electrodes, or any other sufficiently non-corrodable material, with the shape and sizes shown in figure 7.

NOTE: In the IRAM standard 2339 additional details are included regarding the way to carry out this test.

6.4.2 The electrodes are placed on a plain, horizontal area of the test specimen, whose dimensions shall not be, if

6.4.3 In a serial way with the electrodes, a variable resistor is connected and the whole of it to a supply source of a.c. 50 Hz, with a voltage of 175 V and practically senoidal. The total impedance of the circuit is adjusted by changing the resistance of the resistor in such a way that it allows the current running along the shortcircuited electrodes to be regulated to 1 A ± 0.1 A, and the voltmeter voltage falls no more than 10% when the circulation of this current is made. The circuit may be completed with a fuse or any other element protecting against

possible, lower than 15 mm by 15 mm, in such a way that the whole width of these electrodes lies on this area and that each of them makes a force of around 1 N.

overintensities, which works when the electrodes are in shortcircuit.

IRAM 3063:2001

6.4.4 The specimen's area is moistened using an ammonium chloride solution in water for analysis, with a volumetric resistivity of $400 \Omega \cdot \text{cm}$ at 25°C , corresponding to a concentration of around 0.1%.

from 20 mm^3 to 25 mm^3 of the solution specified in 6.4.4, with an interval of $30 \text{ s} \pm 5$, from a height of 30 mm to 40 mm and at half the distance between the electrodes. The number of drops necessary to produce the flow of current between the electrodes is allowed to fall.

6.4.5 The electrodes are placed on the test areas, separated $4 \text{ mm} \pm 0.1 \text{ mm}$, and by an appropriate dripping means, several drops are dropped, whose volume is

6.4.6 The process is continued until a disruptive discharge takes place or until 50 drops have fallen.

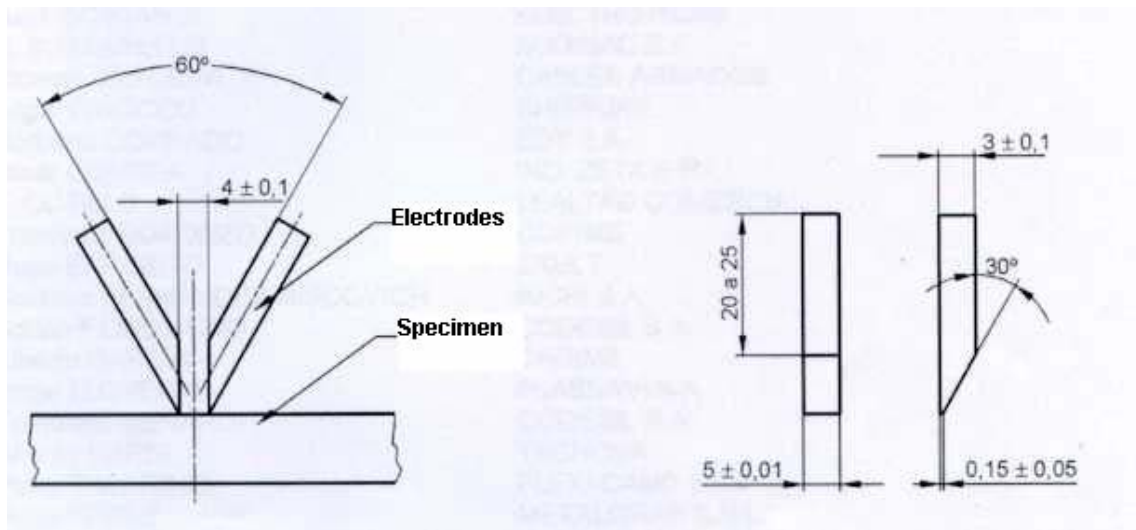

Figure 7 – Layout and dimensions of the electrodes for the superficial dielectric rigidity test

IRAM 2063:2001

Annex A
(Informative)

Bibliography

In the review of this standard, the following background was considered:

IRAM – INSTITUTO ARGENTINO DE NORMALIZACIÓN

IRAM 2063:1982 – Bipolar electrical plugs without ground connection to be used with sockets in fixed household installations with a nominal voltage of 220 V.

Annex B
(Informative)

The review of this standard has been performed by the corresponding commissions, made up in the following way:

Plug and outlet for household use Commission

Members

Eng. Federico ANDRIBEL
Mr. Julio AMAYA
Tec. Luis A. ATTA
Eng. Juan BARGARDI
Eng. H. BOZZARELLO
Mr. Ricardo BRACCINI
Mr. Angel CIROCCO
Eng. Norberto CORRADO
Mr. Omar CORREA
Mr. F. CUTILLO
Tec. Francisco DORONZO
Eng. Hugo EXPOSITO
Eng. Gustavo FERNANDEZ MISCOVICH
Mr. Adrián FIORENTINO
Mr. Alberto GARCIA
Eng. Jorge LLOVERAS
Mr. Francisco MENARDI
Eng. Andrés NARDI
Eng. Pablo PALADINO
Mr. Hugo PEREZ
Mr. Omar RODRIGUEZ
Mr. Sebastián SKRYPNYK
Eng. Rubens STANGLINI

Representing:

ENRE
SYBYSA S.A.
COVRE S.A.
ELECTROTRINO
AUDINAC S.A.
CABLES ARMADOS
SHITSUKE
EDY S.A.
IND. ZETA S.R.L.
LEALTAD COMERCIAL
COPIME
EXULT
RICHI S.A.
CODESIL S.A.
CADIME
PLASNAVI S.A.
CODESIL S.A.
TECNOVA
FLEXI-CAMP S.A.
METALGRAB S.R.L.
MULTIFICHAS LOGIC S.R.L.
KALOP
IRAM

Standards General Committee (N.G.C.)

Members

Eng. Juan C. ARCIONI
Eng. Severiano ITUARTE
Eng. Samuel MARDYKS
Eng. Norberto O'NEILL
Dr. Mario PECORELLI
Eng. Raúl DELLA PORTA

APPROVAL AS MODIFICATION N° 1:2003**TO IRAM STANDARD 2063:2001**

Bipolar electrical ungrounded plug for 10 A, 250 V of alternating current, for household and similar uses

November 2003

The General Board, notifying the Steering Committee in their meeting held on 03-11-17 (Record N° 719), considering the proposal made by the Household Outlet and Plug Subcommittee, in their meeting of 03-08-19 (Redord 6-2003), has approved as

Modification N°1:11/2003

The Emergency Modification N° 1 to the IRAM standard 2063:2001, as follows:

I) **Item 6.3** The current text in this item is replaced by the following:

6.3 Heat resistance

The plugs will be resistant to heat.

The compliance is verified carrying out the tests specified in chapter 25 of the IEC 60884-1:1994.

NOTE: according to the IECEE interpretation, the exception made in the IEC 60884-1, chapter 25, item b) for the compound of natural or synthetic rubber or a mixture of both shall also apply to the PVC compounds.

II) **Item 4.11** The text:

Superficial dielectric rigidity (steering). For plugs with a protection rate higher than IP OX, once the test specified in 6.4 has been performed, any discharge between the electrods shall take place before 50 drops fall.

is replaced by the following:

Superficial dielectric rigidity (steering). For plugs with a protection rate higher than IP X1, once the test specified in 6.4 has been performed, any discharge between the electrods shall take place before 50 drops fall.

**APPROVAL AS MODIFICATION N° 1*
TO IRAM STANDARD 2063:2001**

Bipolar electrical ungrounded plug, for 10 A, of 200 V
alternating current, for household and similar uses

November 2003

The General Board, considering the Modification proposed by the Household Outlet and Plug Subcommittee in their meeting of 02/08/20 (Record 7-2002), which was approved by the Standards General Committee in their meeting of 02/11/01 (Record 6E), has approved, notifying the Steering Committee, the introduction of the emergency modification stated below, in the epigraph standard which will be enforced until **30 June 2003**.

I) Item 6.3 The current text in this item is replaced by the following:

6.3 Heat resistance

The plugs will be resistant to heat.

The compliance is verified carrying out the tests specified in chapter 25 of the IEC 60884-1:1994.

II) Item 4.11 The text:

Superficial dielectric rigidity (steering). For plugs with a protection rate higher than IP 0X, once the test specified in 6.4 has been performed, any discharge between the electrodes shall take place before 50 drops fall.

is replaced by the following:

Superficial dielectric rigidity (steering). For plugs with a protection rate higher than IP X1, once the test specified in 6.4 has been performed, any discharge between the electrodes shall take place before 50 drops fall.

Standards General Committee (NGC)

Members

Eng. Juan C. ARCIONI
Eng. Samuel MARDYKS
Eng. Norberto O'NEILL
Dr. Mario PECORELLI
Eng. Raúl DELLA PORTA

*** Valid until 30 June 2003.**