

# 校准证书

## CALIBRATION CERTIFICATE

证书编号:



第 1 页 共 3 页

Certificate No.

J202110107626-0002

Page

of

委托方

HK LEE HING INDUSTRY CO., LIMITED

Client

联络信息

See more at: <http://www.china-gauges.com/>

Contact Inf.

仪器名称

IP2XC Test Probe with 50N

Description

型号/规格

LX-IP2CT

制造厂

HK LEE HING  
INDUSTRY CO.,  
LIMITED

Model/Type

Manufacturer

出厂编号

JLX2021G201225

管理号

-----

Serial No.

Asset No.

接收日期

2021年10月13日

校准日期

2021年10月18日

Receipt Date

Y M D

Cal. Date

Y M D

发布日期

2021年10月18日

Issued Date

Y M D

批准

李平 (副总工)

Approved by

审核

伍水生

Inspected by

校准

曾佩余

Calibrated by

证书专用章

(Stamp)

总部地址(Headquarters Add.): 广东省广州市黄埔大道西平云路163号

No.163.Pingyun Rd, West of HuangPu Ave.Guangzhou Guangdong China

实验室地址(Add.of the Lab): 广东省广州市黄埔大道西平云路163号

No.163.Pingyun Rd,West of HuangPu Ave.Guangzhou,Guangdong,China

联系电话(Tel.):400-602-0999

邮政编码(Postcode):510656

扫一扫验真伪

网站(Website):[http:// www.grgtest.com](http://www.grgtest.com)

电子邮件(E-mail):[grgtest@grgtest.com](mailto:grgtest@grgtest.com)

## 校 准 说 明

### DIRECTIONS OF CALIBRATION

证书编号: J202110107626-0002

第 2 页 共 3 页

**Certificate No.**

Page of

- 1.本实验室的质量管理体系符合ISO/IEC 17025:2017标准的要求。  
(The quality system is in accordance with ISO/IEC 17025:2017.)
- 2.本结果仅对本次校准样品有效。未经实验室批准,不得部分复制。如有疑问请在15个工作日内反馈。  
(The result is only valid for the calibrated sample.The certificate shall not be reproduced except in full,without the written approval of our laboratroy .please feedback to us within 15 days if you have any question.)
- 3.本证书编号具有唯一性,后缀若带有“-Gx”的证书为替换证书,自发出后原证书即刻作废。  
(Each certificate has a unique number. The suffix of "-Gx" will be added to the number as a replacement of the old version. The original certificate will be officially invalid once the new certificate number is issued.)
- 4.证书中最大允许误差、判定结果仅供参考,其中“P”代表“合格”,“F”代表“不合格”,“N/A”代表“不适用”。使用人员应结合实际测量需求,评估测量不确定度对符合性评定的影响。(MPE & judgement result in the datasheet is only for reference, "P" is "Pass", "F" is "Fail" and "N/A" is "Not Applicable".Whereas users should evaluate the effects of MU of calibration results on conformance assessment by actual measurement.)
- 5.本次校准的技术依据及CNAS认可范围,超出范围的内容未被认可。详细认可范围请查看CNAS网站中的证书附件。(Reference document and accredited scope by CNAS for calibration, beyond which isn't accredited. Please see the certificate attachments on the CNAS website.)

GRGJL.WI-CD-09-QBJZ100-2016试验指、棒、销、钩、探针校准方法 (Test finger,rod,pin,hock,probe) 长度: (0~1000) mm 角度: 10°~120°力值: (0.001~200) N

6. 本次校准使用的主要测量标准(Main Standards of Measurement Used in the Calibration.):

名称 Description	编号 Serial No.	证书号/有效期 Certificate No./ Due Date	溯源机构 Traceability Institute	技术特征 Technique Character
图像处理万能工具显微镜 Toolmaker's Microscope	ZH0020	CYY202100232 2022-03-17	广东省计量科学 研究院	MPE: (1+L/100)μm
推拉力计 Digital Push & Pull Tester	401985	J202101134608- 0005 2022-01-12	广州广电计量检 测股份有限公司	1.0级

7. 校准地点、环境条件(Place and environmental conditions of the calibration):

地点 Place	广州计量长度精密测量室	温度 Temperature	20.3 °C	相对湿度 Relative Humidity	67 %
-------------	-------------	-------------------	---------	---------------------------	------

8. 建议复校时间间隔: 1 年,送校单位也可按实际使用情况自主决定。  
Suggested calibration interval is 1 year or it can be altered depending on the actual usage of the user.



## 校准结果 RESULTS OF CALIBRATION

证书编号: J202110107626-0002

第 3 页 共 3 页

Certificate No.

Page of

1、外观: 符合要求

Appearance: Pass

2、尺寸测量:

Dimension measurement:

标准要求(mm) Specifications	实测值 (mm) Measured Value	扩展不确定度 (mm) $U(k=2)$	结论 (P/F) Conclusion
12.5 <sup>+0.2</sup> <sub>0</sub>	12.60	0.02	P

3、力值测量:

Force measurement

标称值 (N) Nominal	实测值 (N) Measured Value	扩展不确定度 $U_{rel}(k=2)$
10	10.2	5%
20	19.9	5%
30	29.8	5%
40	39.6	5%
50	49.3	5%

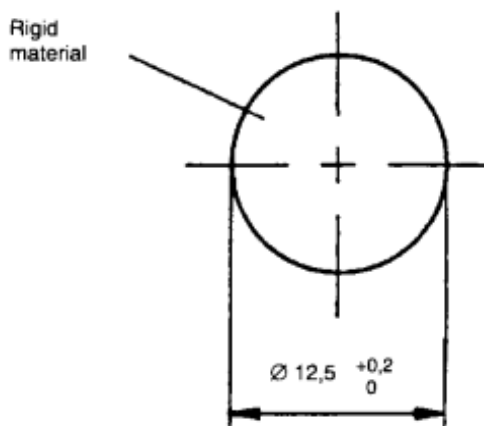

备注:

Notes:

1. 结论(Conclusion): 按校准结果使用

2. 本报告中的扩展不确定度是由标准不确定度乘以包含概率约为95%时的包含因子 $k$ 。

The expanded uncertainty is given in the report by the standard uncertainty multiplied by the probability of about 95% when the factor  $k$ .

3. 依据(Reference document)

JJF 1059.1-2012 测量不确定度评定与表示

(JJF 1059.1-2012 Evaluation and Expression of Uncertainty in Measurement)

4. 技术指标来自于:

IEC61032

Technical indicators source:

(以下空白)

(The below is blank)