



# 校准证书

## CALIBRATION CERTIFICATE

证书编号:  
Certificate No.



J201908263183-0002

第 1 页 共 4 页  
Page of

委托方  
Client

HK LEE HING INDUSTRY CO., LIMITED

委托方地址  
Address

See more at: <http://www.china-gauges.com/>

仪器名称  
Description

E27 Holder for Torque Test on Lamps with Screw Caps of IEC 60432-1 Fig. C.2

型号/规格  
Model/Type

LX-E27NH

制造厂  
Manufacturer

HK LEE HING INDUSTRY CO., LIMITED

出厂编号  
Serial No.

JLX2019G108828

管理号  
Asset No.

-----

校准日期  
Date of Calibration

2019年09月02日

Y M D

样品接收日期  
Date of Receipt

2019年08月27日

Y M D

批准人:  
Approved Signatory

刘文鸣 (副总监)

审核:  
Inspected by

伍水生

校准:  
Calibrated by

黄星顺

证书专用章  
(Stamp)

总部地址: 广东省广州市黄埔大道西平云路163号(分场所地址见公司网站)

Headquarters Address: No.163.Pingyun Rd, West of HuangPu Ave.Guangzhou.  
Guangdong.China(Each Address Can be Found on The Company's Website)

联系电话(Tel.): 020-38699960, 66830999, 400-602-0999

传真(Fax): 020-38695185

邮政编码(Postcode): 510656

扫一扫验真伪

网站(Website): [http:// www.grgtest.com](http://www.grgtest.com)

电子邮件(E-mail): [grgtest@grgtest.com](mailto:grgtest@grgtest.com)



## 校准说明

### DIRECTIONS OF CALIBRATION

证书编号: J201908263183-0002

第 2 页 共 4 页

**Certificate No.**

Page of

1. 本实验室出具的数据均可溯源至国家计量基准和国际单位制(SI)。  
(All data issued by GRGTest are traced to National Primary Standards and International System of Units(SI).)
2. 本结果仅对当次被测样品有效, 如有疑问请在15个工作日内反馈。(The result is ONLY valid for the tested sample, please feedback to us within 15 working days if you have any question.)
3. 本证书编号具有唯一性, 后缀若带有“-Gx”的证书为替换证书, 自发出后原证书即刻作废。  
(Each certificate has a unique number. The suffix of "-Gx" will be added to the number as a replacement of the old version. The original certificate will be officially invalid once the new certificate number is issued.)
4. 证书中如有最大允许误差、判定结果, 仅供参考, 其中“P”代表“合格”, “F”代表“不合格”。使用人员还应结合实际测量要求, 评估校准结果测量不确定度对符合性评定的影响。(MPE & judgement result in the datasheet is only for reference, "P" represents "Pass" and "F" represents "Fail".Whereas users should evaluate the effects of measurement uncertainty of calibration results on conformity determination associated with actual measurement.)
5. 本次校准的技术依据及CNAS认可范围, 超出范围的内容未被认可。注: 详细的认可范围请查看CNAS网站中注册编号为L0446的证书附件。(Reference document and accredited scope by CNAS for calibration, beyond which isn't accredited. Please see the attachment of certificate No.L0446 on CNAS website for details.)  
GRGT (JL) 4002-2017量规校准方法 (Calibration Method of Gauge): 角度(0~360)°、几何尺寸&形位误差: (0~1000)mm、质量(0~3)kg、粗糙度Ra(0.012~6.3)μm、洛氏硬度(1~100)HR、邵氏硬度(0~100)HA HD

6. 本次校准使用的主要测量标准(Main Standards of Measurement Used in the Calibration.):

名称 / 型号 Description / Model	编号 Serial No.	证书号/有效期 Certificate No./ Due Date	溯源机构 Traceability Institute	技术特征 Technique Character
数显测高仪/ID-C150MXB	08136975	J201907252222-0004 2020-08-01	广州广电计量检测股份有限公司	MPE: ±0.005mm
图像处理万能工具显微镜/JX13C	ZH0020	CYY201900266 2020-03-24	广东省计量科学研究院	MPE: (1+L/100)μm
螺纹综合测量机/MSXP6060	103628	CDIz2018-1581 2019-10-18	中国计量科学研究院	En小于1

7. 校准地点、环境条件(Place and environmental conditions of the calibration):

地点 Place	广州计量长度精密测量室	温度 Temperature	21 °C	相对湿度 Relative Humidity	60 %
-------------	-------------	-------------------	-------	---------------------------	------

8. 建议复校时间间隔: 1 年, 送校单位也可按实际使用情况自主决定。  
Suggested calibration interval is 1 year or it can be altered depending on the actual usage of the user.

校 准 结 果  
RESULTS OF CALIBRATION

证书编号: J201908263183-0002

第 3 页 共 4 页

Certificate No.

Page of

1、外观以及一般性检查: 符合要求

Appearance: Pass

2、尺寸测量:

Dimension measurement:

尺寸代号 Size code	标准要求 (mm) Specifications	实测值 (mm) Measured value	扩展不确定度 (mm) $U(k=2)$	结论 (P/F) Conclusion
C	Min.32	38.00	0.02	P
K	$13.5 \begin{smallmatrix} 0 \\ -0.3 \end{smallmatrix}$	13.48	0.02	P
O	$23 \begin{smallmatrix} +0.1 \\ -0.1 \end{smallmatrix}$	23.04	0.02	P
S	12	13.98	0.02	P
d	$26.45 \begin{smallmatrix} +0.1 \\ 0 \end{smallmatrix}$	26.47	0.02	P
d1	$24.26 \begin{smallmatrix} +0.1 \\ 0 \end{smallmatrix}$	24.33	0.02	P
P	3.629	2.83	0.02	---
r	1.025	1.02	0.02	---



# 校准结果 RESULTS OF CALIBRATION

证书编号: J201908263183-0002

Certificate No.

第 4 页 共 4 页

Page of

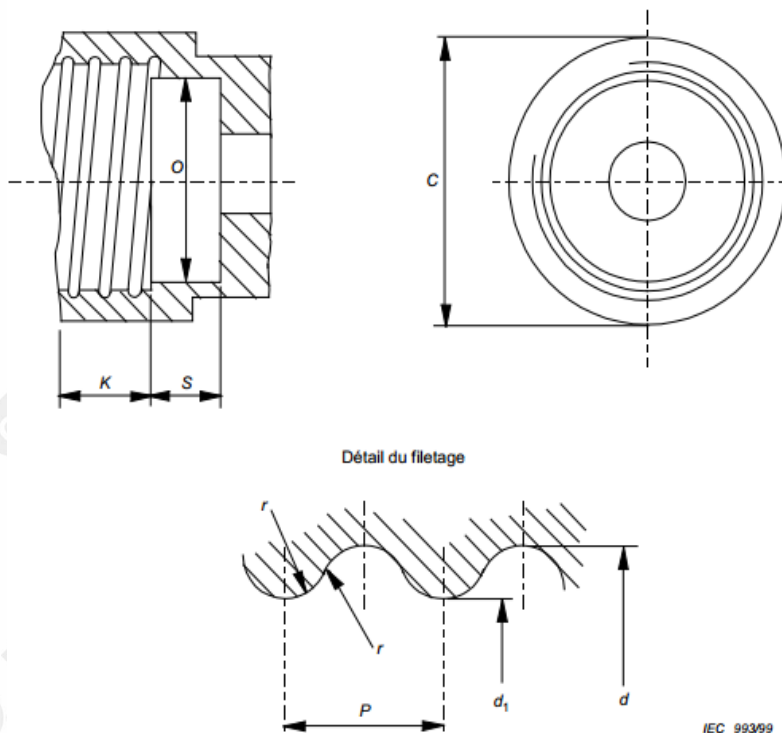

备注 Notes:

结论 (Conclusion): 按校准结果使用

1.本报告中的扩展不确定度是由标准不确定度乘以包含概率约为95%时的包含因子 $k$ 。  
The expanded uncertainty is given in the report by the standard uncertainty multiplied by the probability of about 95% when the factor  $k$ .

2.依据(Reference document)

JJF 1059.1-2012 测量不确定度评定与表示

(JJF 1059.1-2012 Evaluation and Expression of Uncertainty in Measurement)

(以下空白)  
(The below is blank)