

Arc welding equipment —

Part 2: Liquid cooling systems

<http://www.china-gauges.com/>

ICS 25.160.30

National foreword

This British Standard is the UK implementation of EN 60974-2:2008. It is identical to IEC 60974-2:2007. It supersedes BS EN 60974-2:2003 which is withdrawn.

The UK participation in its preparation was entrusted to Technical Committee WEE/6, Electric arc welding equipment.

A list of organizations represented on this committee can be obtained on request to its secretary.

This publication does not purport to include all the necessary provisions of a contract. Users are responsible for its correct application.

Compliance with a British Standard cannot confer immunity from legal obligations.

<http://www.china-gauges.com/>

This British Standard was published under the authority of the Standards Policy and Strategy Committee on 28 February 2009

© BSI 2009

ISBN 978 0 580 56863 3

Amendments/corrigenda issued since publication

Date	Comments

English version

Arc welding equipment
Part 2: Liquid cooling systems
(IEC 60974-2:2007)

Matériel de soudage à l'arc
Partie 2: Systèmes
de refroidissement par liquide
(CEI 60974-2:2007)

Lichtbogenschweißeinrichtungen -
Teil 2: Flüssigkeitskühlsysteme
(IEC 60974-2:2007)

This European Standard was approved by CENELEC on 2008-02-01. CENELEC members are bound to comply with the CEN/CENELEC Internal Regulations which stipulate the conditions for giving this European Standard the status of a national standard without any alteration.

Up-to-date lists and bibliographical references concerning such national standards may be obtained on application to the Central Secretariat or to any CENELEC member.

This European Standard exists in three official versions (English, French, German). A version in any other language made by translation under the responsibility of a CENELEC member into its own language and notified to the Central Secretariat has the same status as the official versions.

CENELEC members are the national electrotechnical committees of Austria, Belgium, Bulgaria, Cyprus, the Czech Republic, Denmark, Estonia, Finland, France, Germany, Greece, Hungary, Iceland, Ireland, Italy, Latvia, Lithuania, Luxembourg, Malta, the Netherlands, Norway, Poland, Portugal, Romania, Slovakia, Slovenia, Spain, Sweden, Switzerland and the United Kingdom.

CENELEC

European Committee for Electrotechnical Standardization
Comité Européen de Normalisation Electrotechnique
Europäisches Komitee für Elektrotechnische Normung

Central Secretariat: rue de Stassart 35, B - 1050 Brussels

Foreword

The text of document 26/362/FDIS, future edition 2 of IEC 60974-2, prepared by IEC TC 26, Electric welding, was submitted to the IEC-CENELEC parallel vote and was approved by CENELEC as EN 60974-2 on 2008-02-01.

This European Standard supersedes EN 60974-2:2003.

EN 60974-2:2007 includes the following significant technical changes with respect to EN 60974-2:2003:

- changes induced by the publication of EN 60974-1:2005;
- introduction of a set-up for torch simulation during leakage test;
- complementary requirement for attachment plug in 125 V supply network;
- introduction of new items in instructions;
- correction of density value for water/alcohol (50/50);
- improvement of rating plate example.

This standard is to be used in conjunction with EN 60974-1:2005.

The following dates were fixed:

- latest date by which the EN has to be implemented
at national level by publication of an identical
national standard or by endorsement (dop) 2008-11-01
- latest date by which the national standards conflicting
with the EN have to be withdrawn (dow) 2011-02-01

Annex ZA has been added by CENELEC.

Endorsement notice

The text of the International Standard IEC 60974-2:2007 was approved by CENELEC as a European Standard without any modification.

CONTENTS

<http://www.china-gauges.com/>

1	Scope	6
2	Normative references	5
3	Terms and definitions	5
4	Environmental conditions	5
5	Tests	6
5.1	Test conditions	6
5.2	Measuring instruments	6
5.3	Conformity of components	6
5.4	Type tests	6
5.5	Routine tests	6
6	Protection against electric shock	7
6.1	Insulation	7
6.2	Protection against electric shock in normal service (direct contact)	7
6.3	Protection against electric shock in case of a fault condition (indirect contact)	7
6.4	Connection to the input supply network	7
6.5	Leakage current between welding circuit and protective earth	8
7	Mechanical provisions	8
7.1	General	8
7.2	Cooling liquid overflow	9
7.3	Hose coupling devices and hose connections	9
8	Cooling system	9
8.1	Rated maximum pressure	9
8.2	Thermal requirements	9
8.3	Pressure and temperature	9
9	Abnormal operation	9
9.1	General requirements	9
9.2	Stalled test	10
10	Cooling power	10
10.1	Test procedure	10
11	Rating plate	10
11.1	General	12
11.2	Description	12
11.3	Contents	12
11.4	Tolerances	13
12	Instructions	13
12.1	Supplied documents and information	13
13	Marking	14
13.1	General markings	14
13.2	Inlet and outlet	14
13.3	Pressure warning	14

Annex A (informative) Example diagram of built-in and stand-alone liquid cooling systems 15

Annex B (informative) Example for a rating plate of stand-alone cooling system 16

Annex ZA (normative) Normative references to international publications with their corresponding European publications 17

Figure 1 – Leakage current measurement configuration 8

Figure 2 – Measuring circuit for determination of the cooling power 11

Figure 3 – Principle of the rating plate of stand-alone cooling systems 12

Figure A.1 – Example diagram of built-in liquid cooling systems 15

Figure A.2 – Example diagram of stand-alone liquid cooling systems 15

Table 1 – Example of cooling liquid data at 60 °C 11

<http://www.china-gauges.com/>

ARC WELDING EQUIPMENT –

Part 2: Liquid cooling systems

1 Scope

This part of IEC 60974 specifies safety and construction requirements for industrial and professional liquid cooling systems used in arc welding and allied processes to cool torches.

This part of IEC 60974 is applicable to stand-alone liquid cooling systems that are either connected to a separate welding power source or built into the welding power source enclosure.

This part of IEC 60974 is not applicable to refrigerated cooling systems.

NOTE 1 Typical allied processes are, for example, plasma arc cutting and arc spraying.

NOTE 2 This part of IEC 60974 does not include electromagnetic compatibility (EMC) requirements.

2 Normative references

The following referenced documents are indispensable for the application of this document. For dated references, only the edition cited applies. For undated references, the latest edition of the referenced document (including any amendments) applies.

IEC 60974-1:2005, *Arc-welding equipment – Part 1: Welding power sources*

IEC 60974-7:2005, *Arc-welding equipment – Part 7: Torches*

IEC 60974-10, *Arc welding equipment – Part 10: Electromagnetic compatibility (EMC) requirements*

3 Terms and definitions

For the purposes of this document, the terms and definitions given in IEC 60974-1 and IEC 60974-7, as well as the following, apply.

3.1

cooling power

P

cooling energy related to the mass flow rate

3.2

liquid cooling system

system that circulates and cools liquid used for decreasing the temperature of equipment of arc welding and allied processes

4 Environmental conditions

See Clause 4 of IEC 60974-1.

5 Tests

5.1 Test conditions

See 5.1 of IEC 60974-1.

Stand-alone cooling systems may be tested without a welding power source.

Built-in cooling systems shall be tested with the welding power source.

5.2 Measuring instruments

The accuracy of measuring instruments shall be as follows.

- a) Electrical measuring instruments: class 0,5 ($\pm 0,5$ % of full-scale reading), except for the measurement of insulation resistance and dielectric strength where the accuracy of the instruments is not specified, but shall be taken into account for the measurement.
- b) Thermometer: ± 2 K.
- c) Pressure measuring instruments: class 2,5.
- d) Flow-rate measuring instruments: class 2,5.

5.3 Conformity of components

See 5.3 of IEC 60974-1.

5.4 Type tests

All type tests shall be carried out on the same cooling system unless specified otherwise.

As a condition of conformity the type tests given below shall be carried out in the following sequence:

- a) general visual inspection (see 3.7 of IEC 60974-1);
- b) protection provided by the enclosure (see 6.2.1 of IEC 60974-1);
- c) mechanical provisions (see Clause 7);
- d) insulation resistance (see 6.1.4);
- e) dielectric strength (see 6.1.5).

The other tests included in this standard and not listed here may be carried out in any convenient sequence.

5.5 Routine tests

All routine tests given below shall be carried out on each cooling system in the following sequence:

- a) general visual inspection (see 3.7 of IEC 60974-1);
- b) continuity of the protective circuit (see 10.4.2 of IEC 60974-1);
- c) dielectric strength (see 6.1.5);
- d) general visual inspection (see 3.7 of IEC 60974-1; for example leaks of cooling liquid and flow or pressure sensor operation as specified by the manufacturer).

6 Protection against electric shock

6.1 Insulation

6.1.1 General

See 6.1.1 of IEC 60974-1.

6.1.2 Clearances

See 6.1.2 of IEC 60974-1.

6.1.3 Creepage distances

See 6.1.3 of IEC 60974-1.

6.1.4 Insulation resistance

See 6.1.4 of IEC 60974-1.

The test may be carried out without cooling liquid.

6.1.5 Dielectric strength

See 6.1.5 of IEC 60974-1.

The test may be carried out without cooling liquid.

6.2 Protection against electric shock in normal service (direct contact)

See 6.2 of IEC 60974-1.

6.3 Protection against electric shock in case of a fault condition (indirect contact)

6.3.1 Protective provisions

See 6.3.1 of IEC 60974-1.

6.3.2 Isolation of the supply circuit and the welding circuit

See 6.3.2 of IEC 60974-1.

6.3.3 Insulation between windings of the supply circuit and the welding circuit

See 6.3.3 of IEC 60974-1.

6.3.4 Internal conductors and connections

See 6.3.4 of IEC 60974-1.

6.3.5 Primary leakage current

See 6.3.7 of IEC 60974-1.

6.4 Connection to the input supply network

See Clause 10 of IEC 60974-1.

<http://www.china-gauges.com/>

Additionally, for 125 V input supply networks, the current rating of the attachment plug shall be not less than 70 % of the supply current, as measured with the fan motor or pump stalled, whichever is greater.

6.5 Leakage current between welding circuit and protective earth

With the cooling system filled with the cooling liquid specified by the manufacturer (see 12.1e)), the leakage current from the torch to the protective earth connection of the cooling system shall not exceed 10 mA d.c.

The design of the torch can influence the leakage current value; therefore, a conventional copper pipe shall be used to simulate the torch during the conformity test.

Conformity shall be checked by applying a d.c. voltage of 500 V at room temperature between the protective earth connection and a copper pipe to simulate the torch connected to the output of the cooling system pump. A hose with a maximum length of 0,5 m as shown in Figure 1. The minimum inner diameter of the hose shall be 5 mm. The minimum length of the copper pipe shall be 10 cm with a minimum internal diameter of 5 mm. The cooling system and the simulated torch are filled with liquid for the test. The pump is operating.

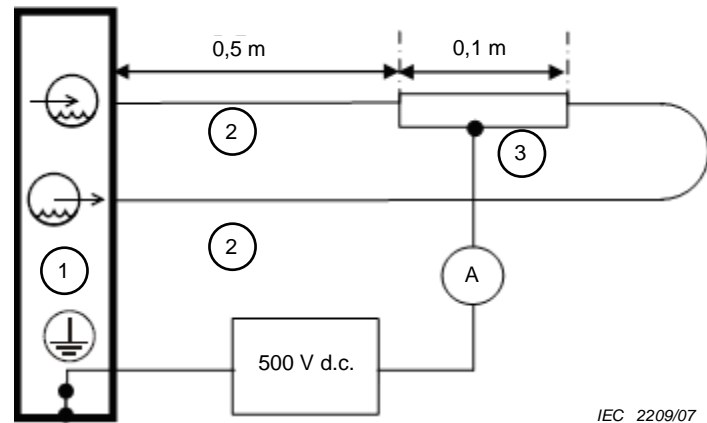

Key

- 1 Liquid cooling system
- 2 Hose
- 3 Copper pipe

Figure 1 – Leakage current measurement configuration

7 Mechanical provisions

7.1 General

See Clause 14 of IEC 60974-1.

The test shall be carried out with cooling liquid.

7.2 Cooling liquid overflow

When filling the cooling system in accordance with the manufacturer's instructions, overflow or spillage shall not result in electric shock.

Conformity shall be checked by the following treatment and test. The liquid container is completely filled. A further quantity of liquid equal to 15 % of the capacity of the container or 0,25 l, whichever is the greater, is then poured in steadily over a period not to exceed 60 s. Immediately after this treatment, the equipment shall pass the dielectric strength test of 6,1 kV between input circuits and exposed conductive parts.

7.3 Hose coupling devices and hose connections

If hose coupling devices or hose connections, which often have to be undone, are placed above or near to live parts, these live parts shall be protected from cooling liquid by splash proof enclosures, with drains or other appropriate measures. An exception is made for live parts of the welding circuit.

8 Cooling system

8.1 Rated maximum pressure

The manufacturer shall determine the rated maximum pressure attainable by the cooling system (see 11.3c), box 12).

Conformity shall be checked by measuring the pressure when the outlet is blocked.

8.2 Thermal requirements

8.2.1 Heating test

Liquid cooling systems shall be capable of operating at rated cooling power without causing any component to exceed its rated temperature.

Conformity shall be checked in accordance with Clause 10.

8.2.2 Tolerances of test parameters

- a) p pressure: $p_{-2\%}^{+10\%}$
- b) q_v volume flow: $q_{v-2\%}^{+10\%}$
- c) T temperature: $T \pm 2 \text{ K}$

8.2.3 Duration of test

See 7.1.3 of IEC 60974-1.

8.3 Pressure and temperature

Liquid cooling systems shall be capable of operating without leakage at the maximum pressure with a cooling liquid temperature of 70 °C.

Conformity shall be checked by visual inspection during 120 s of operation or until shutdown by a protection system, immediately following the heating test while the outlet of the cooling system is blocked.

9 Abnormal operation

9.1 General requirements

A cooling system shall not suffer hazardous electrical breakdown or cause a risk of fire under the conditions of operation of 9.2. These tests are conducted without regard to temperature attained on any part, or the continued proper functioning of the cooling system. The only

criterion is that the cooling system does not become unsafe. These tests may be conducted on other cooling systems.

The cooling system, protected internally by, for example, a circuit-breaker or thermal protection, meets this requirement if the protection device operates before an unsafe condition occurs.

Conformity shall be checked by the following tests.

- a) A layer of dry absorbent surgical type cotton is placed under the cooling system, extending beyond each side for a distance of 150 mm.
- b) Starting from the cold state, the cooling system is operated in accordance with 9.2.
- c) During the test, the cooling system shall not emit flames, molten metal or other materials that ignite the cotton indicator.
- d) Following the test and within 5 min, the cooling system shall be capable of withstanding a dielectric test in accordance with 6.1.5.

9.2 Stalled test

A cooling system, which relies on motor-driven fan(s) and pump(s) for conformity with the tests of 8.2, is operated at rated supply voltage or rated load speed for a period of 4 h while the fan motor(s) and pump(s) is(are) stalled or disabled at the output condition of 8.2.1, which produces the maximum heating.

NOTE The intention of this test is to run the cooling system with the fan stationary. The fan may be blocked mechanically or disconnected.

10 Cooling power

10.1 Test procedure

Cooling power data shall be given in kW for 100 % duty cycle (duty factor), with the cooling liquid as recommended by the manufacturer and at an ambient air temperature at 25 °C (see tolerances of test parameters in 8.2.2). For these values the volume flow shall be 1 l/min.

This test may be carried out on a separate cooling system.

A built-in cooling system may additionally be heated by the welding power source. Therefore, the test shall be performed together with the welding power source, set for maximum heating.

Conformity shall be checked by the following test and calculation:

- a) the liquid cooling system is filled with the amount and type of cooling liquid recommended in the manufacturer's instructions;
- b) the liquid cooling system is connected to a measuring circuit according to Figure 2;
- c) the valve is adjusted to obtain a flow of 1 l/min \pm 0,1 l/min;
- d) the electric heater is adjusted to give a stable condition at a temperature 40 K \pm 2 K over ambient air temperature at the inlet of the liquid cooling system;
- e) the inlet and outlet temperature is measured directly at the liquid cooling system. Heat losses of the measuring device should be as low as possible;
- f) the test is carried out for a period of not less than 60 min and continued until the rate of temperature rise does not exceed 2 K/h.

The cooling power is calculated by the following formulae:

$$P = (T_1 - T_2) q_m c \qquad q_m = q_v \rho$$

where

- P is the cooling power (kW);
- T_1 is the temperature of inlet flow (K);
- T_2 is the temperature of outlet flow (K);
- $T_1 - T_2$ is the temperature difference (K);
- q_m is the mass flow (kg/s);
- q_v is the volume flow (l/s);
- c is the specific heat capacity of the cooling liquid (see example in Table 1)(kJ/(kg×K));
- ρ is the density of the cooling liquid (see example in Table 1) (kg/l).

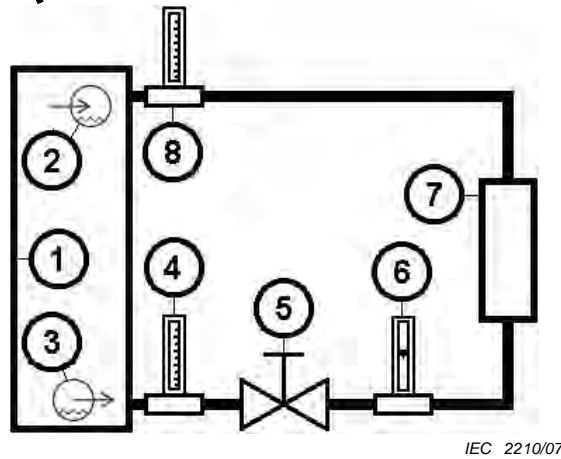

Key

- | | | | | | |
|---|-----------------------|---|-----------------------|---|-----------------------|
| 1 | Liquid cooling system | 4 | Thermometer (T_2) | 7 | Electrical heater |
| 2 | Inlet flow | 5 | Adjustable valve | 8 | Thermometer (T_1) |
| 3 | Outlet flow | 6 | Flow meter | | |

Figure 2 – Measuring circuit for determination of the cooling power

Table 1 – Example of cooling liquid data at 60 °C

Liquid	Specific heat capacity (c) kJ/(kg × K)	Density (ρ) kg/l
Water/ethanol (50/50)	3,85	0,88
Water/ethylene glycol (50/50)	3,44	1,07
Water/propylene glycol (50/50)	3,69	1,04
Water/ethylene glycol (10/90)	2,670	1,10
Water/propylene glycol (10/90)	2,846	1,02

NOTE Figures in parentheses in column 1 are volume ratios.

11 Rating plate

11.1 General

See Clause 15 of IEC 60974-1.

11.2 Description

The rating plate shall be divided into three sections:

- a) identification of stand-alone cooling systems;
- b) energy input of stand-alone cooling systems
- c) liquid cooling system.

The arrangement and sequence of the data shall comply with the principle shown in Figure 3 (for an example, see Annex B).

The dimensions of the rating plate are not specified and may be chosen freely.

NOTE Additional information may be given, if necessary, on a special rating plate. Further useful information may be given in technical literature supplied by the manufacturer (see Clause 12).

In the case of built-in cooling systems, section c) of Figure 2 shall be added to the rating plate of the welding power source. See Clause 15 of IEC 60974-1.

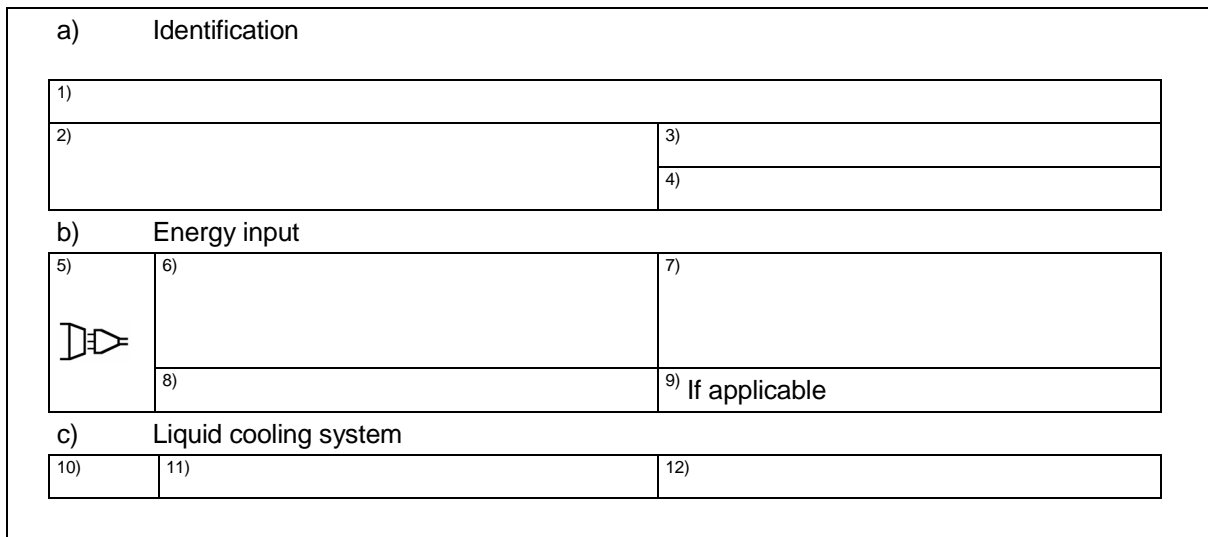

Figure 3 – Principle of the rating plate of stand-alone cooling systems IEC 2211/07

11.3 Contents

a) Identification

- Box 1 Name and address of the manufacturer and if required distributor, importer, a trade mark and the country of origin
- Box 2 Type (identification) as given by the manufacturer
- Box 3 Traceability of design and manufacturing data (for example, serial number)
- Box 4 Reference to IEC 60974-2 confirming that the cooling system complies with its requirements

b) Energy input

- Box 5 Symbol for mains supply

Box 6	$U_1 \dots V / 1(3)\sim \dots \text{ Hz}$	Rated supply voltage, number of phases (for example, 1 or 3), symbol for a.c. current \sim , and rated frequency, for example, 50 Hz or 60 Hz
Box 7	$I_{1\text{max}} \dots \text{ A}$	Maximum rated supply current
Box 8	IP	Degree of protection, for example, IP 21S or IP 23S
Box 9		Symbol for protection class IP, if applicable

c) Liquid cooling system

Box 10		Symbol for cooling
Box 11	$P_1 \text{ l/min} \dots \text{ kW}$	Rated cooling power at 1 l/min of cooling liquid flow at 25 °C
Box 12	$p_{\text{max}} \dots \text{ Pa (bar)}$	Rated maximum pressure

Conformity shall be checked by visual inspection and by checking of the complete data.

11.4 Tolerances

Manufacturers shall meet rating plate values within the following tolerances by controlling component and manufacturing tolerances:

- a) P cooling power in kW
The value shall be not less than that stated on the rating plate.
- b) p_{max} rated maximum pressure in Pa (bar)
The value shall be not greater than that stated on the rating plate.

Conformity shall be checked by comparing the values with those stated on the rating plate.

12 Instructions

12.1 Supplied documents and information

Each cooling system shall be delivered with instructions including the following, as applicable:

- a) general description;
- b) weight and correct methods of handling stand-alone liquid cooling systems;
- c) meaning of indications and graphical symbols;
- d) interface requirements for an arc welding power source, for example control power, control signals, static characteristics and means of connections;
- e) correct operational use of the liquid cooling system, for example cooling liquid, cooling conditions, location, pump characteristic, cooling power characteristic, antifreezes, recommended additives, pressure range, etc.;
- f) limitations and explanation of thermal protection, if relevant;
- g) limitations related to the degree of protection provided, for example a cooling system with a degree of protection of IP 21S is not suitable for storage or use in rain or snow;
- h) conditions under which extra precautions are to be observed when welding or cutting, for example environment with increased hazard of electric shock;

- i) maintenance and service of the liquid cooling system;
- j) adequate circuit diagram together with a list of recommended spare parts;
- k) warning against the use of non-suitable and conductive cooling liquids and antifreezes;
- l) precautions against toppling over, if the liquid cooling system shall be placed on a tilted plane;
- m) correct handling and disposal of the cooling liquid;
- n) EMC classification in accordance with IEC 60974-10 (stand-alone cooling systems only);
- o) a statement drawing attention to the fact that the ratings were developed at an ambient temperature of 20 °C to 25 °C and the operating ranges specified as -10 °C to +40 °C.

Conformity shall be checked by reading the instructions.

13 Marking

13.1 General markings

See 17.2 of IEC 60974-1.

13.2 Inlet and outlet

The inlet and outlet connections for the cooling liquid shall be clearly and indelibly marked with the following symbols.

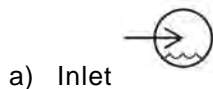

In addition, a colour code may be used.

13.3 Pressure warning

If the rated maximum pressure of the liquid cooling system is higher than 0,5 MPa (5 bar), a warning shall be attached, for instance:



p_{\max} X MPa

Annex A
(informative)

Example diagram of built-in and stand-alone liquid cooling systems

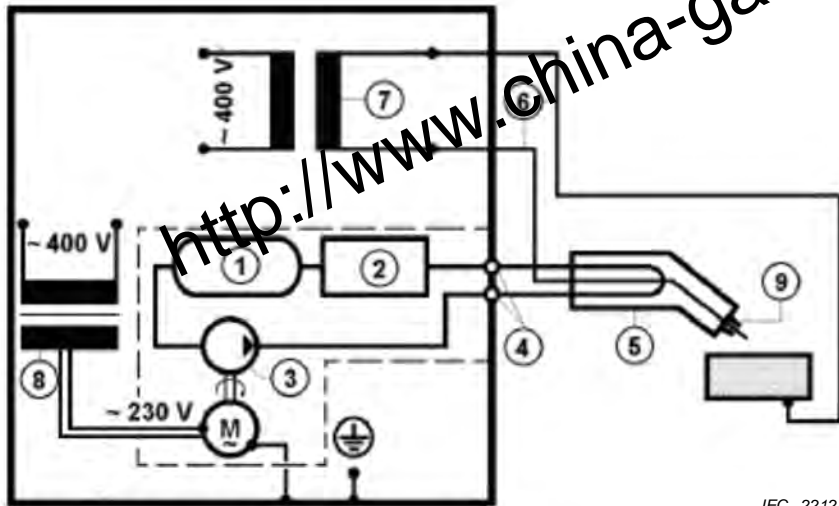

Key

- | | |
|---------------------------------|-----------------------|
| 1 Tank | 6 Welding circuit |
| 2 Heat exchanger | 7 Welding transformer |
| 3 Pump | 8 Transformer |
| 4 Grounded cooling liquid pipes | 9 Contact tip |
| 5 Torch | |

Figure A.1 – Example diagram of built-in liquid cooling systems

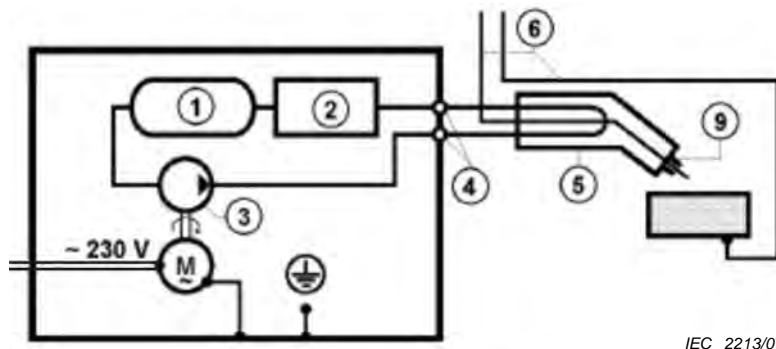



Key

- | | |
|---------------------------------|-------------------|
| 1 Tank | 5 Torch |
| 2 Heat exchanger | 6 Welding circuit |
| 3 Pump | 9 Contact tip |
| 4 Grounded cooling liquid pipes | |

Figure A.2 – Example diagram of stand-alone liquid cooling systems

Annex B
(informative)

Example for a rating plate of stand-alone cooling system

a) Identification			
1) Manufacturer		Trademark	
Address			
2) Type		3) Serial No.	
		4) IEC 60974-2	
b) Energy input			
5) 	6) $U_1 = 230 \text{ V} / 1\sim 50 \text{ Hz}$	7) $I_{1\text{max}} = 1,2 \text{ A}$	
	8) IP 23S	9) —	
c) Liquid cooling system			
10) 	11) $P_1 \text{ l/min} = 0,55 \text{ kW}$	12) $p_{\text{max}} = 0,38 \text{ MPa}$	

<http://www.china-gauges.com/>

Annex ZA
(normative)

**Normative references to international publications
with their corresponding European publications**

The following referenced documents are indispensable for the application of this document. For dated references, only the edition cited applies. For undated references, the latest edition of the referenced document (including any amendments) applies.

NOTE When an international publication has been modified by common modifications, indicated by (mod), the relevant EN/HD applies.

<u>Publication</u>	<u>Year</u>	<u>Title</u>	<u>EN/HD</u>	<u>Year</u>
IEC 60974-1	2005	Arc welding equipment - Part 1: Welding power sources	EN 60974-1	2005
IEC 60974-7	2005	Arc welding equipment - Part 7: Torches	EN 60974-7	2005
IEC 60974-10	– ¹⁾	Arc welding equipment - Part 10: Electromagnetic compatibility (EMC) requirements	EN 60974-10	2007 ²⁾

¹⁾ Undated reference.

²⁾ Valid edition at date of issue.

BSI — British Standards Institution

BSI is the independent national body responsible for preparing British Standards. It presents the UK view on standards in Europe and at the international level. It is incorporated by Royal Charter.

Revisions

British Standards are updated by amendment or revision. Users of British Standards should make sure that they possess the latest amendments or editions.

It is the constant aim of BSI to improve the quality of our products and services. We would be grateful if anyone finding an inaccuracy or ambiguity while using this British Standard would inform the Secretary of the technical committee responsible, the identity of which can be found on the inside front cover. Tel: +44 (0)20 8996 9000. Fax: +44 (0)20 8996 7400.

BSI offers members an individual updating service called PLUS which ensures that subscribers automatically receive the latest editions of standards.

Buying standards

Orders for all BSI, international and foreign standards publications should be addressed to Customer Services. Tel: +44 (0)20 8996 9001. Fax: +44 (0)20 8996 7001. Email: orders@bsi-global.com. Standards are also available from the BSI website at <http://www.bsi-global.com>.

In response to orders for international standards, it is BSI policy to supply the BSI implementation of those that have been published as British Standards, unless otherwise requested.

Information on standards

BSI provides a wide range of information on national, European and international standards through its Library and its Technical Help to Exporters Service. Various BSI electronic information services are also available which give details on all its products and services. Contact the Information Centre. Tel: +44 (0)20 8996 7111. Fax: +44 (0)20 8996 7048. Email: info@bsi-global.com.

Subscribing members of BSI are kept up to date with standards developments and receive substantial discounts on the purchase price of standards. For details of these and other benefits contact Membership Administration. Tel: +44 (0)20 8996 7002. Fax: +44 (0)20 8996 7001. Email: membership@bsi-global.com.

Information regarding online access to British Standards via British Standards Online can be found at <http://www.bsi-global.com/bsonline>.

Further information about BSI is available on the BSI website at <http://www.bsi-global.com>.

Copyright

Copyright subsists in all BSI publications. BSI also holds the copyright, in the UK, of the publications of the international standardization bodies. Except as permitted under the Copyright, Designs and Patents Act 1988 no extract may be reproduced, stored in a retrieval system or transmitted in any form or by any means – electronic, photocopying, recording or otherwise – without prior written permission from BSI.

This does not preclude the free use, in the course of implementing the standard, of necessary details such as symbols, and size, type or grade designations. If these details are to be used for any other purpose than implementation then the prior written permission of BSI must be obtained.

Details and advice can be obtained from the Copyright & Licensing Manager. Tel: +44 (0)20 8996 7070. Fax: +44 (0)20 8996 7553. Email: copyright@bsi-global.com.