

# Low-voltage switchgear and controlgear —

Part 5-4: Control circuit devices and  
switching elements — Method of  
assessing the performance of  
low-energy contacts — Special tests

The European Standard EN 60947-5-4:2003 has the status of a  
British Standard

ICS 29.130.20

## National foreword

This British Standard is the official English language version of EN 60947-5-4:2003. It is identical with IEC 60947-5-4:2002. It supersedes BS EN 60947-5-4:1997 which is withdrawn.

The UK participation in its preparation was entrusted by Technical Committee PEL/17, Switchgear, controlgear and HV-LV co-ordination, to Subcommittee PEL/17/2, Low-voltage switchgear and controlgear, which has the responsibility to:

- aid enquirers to understand the text;
- present to the responsible international/European committee any enquiries on the interpretation, or proposals for change, and keep the UK interests informed;
- monitor related international and European developments and promulgate them in the UK.

A list of organizations represented on this subcommittee can be obtained on request to its secretary.

### Cross-references

The British Standards which implement international or European publications referred to in this document may be found in the *BSI Catalogue* under the section entitled “International Standards Correspondence Index”, or by using the “Search” facility of the *BSI Electronic Catalogue* or of British Standards Online.

This publication does not purport to include all the necessary provisions of a contract. Users are responsible for its correct application.

**Compliance with a British Standard does not of itself confer immunity from legal obligations.**

This British Standard was published under the authority of the Standards Policy and Strategy Committee on 18 December 2003

### Summary of pages

This document comprises a front cover, an inside front cover, the EN title page, pages 2 to 25 and a back cover.

The BSI copyright notice displayed in this document indicates when the document was last issued.

### Amendments issued since publication

Amd. No.	Date	Comments

© BSI 18 December 2003

ISBN 0 580 43145 2

EUROPEAN STANDARD

**EN 60947-5-4**

NORME EUROPÉENNE

EUROPÄISCHE NORM

December 2003

ICS 29.130.20

Supersedes EN 60947-5-4:1997

English version

**Low-voltage switchgear and controlgear**  
**Part 5-4: Control circuit devices and switching elements -**  
**Method of assessing the performance of low-energy contacts -**  
**Special tests**  
(IEC 60947-5-4:2002)

Appareillage à basse tension  
Partie 5-4: Appareils et éléments  
de commutation pour circuits  
de commande -  
Méthode d'évaluation des performances  
des contacts à basse énergie -  
Essais spéciaux  
(CEI 60947-5-4:2002)

Niederspannungsschaltgeräte  
Teil 5-4: Steuergeräte und Schaltelemente -  
Verfahren zur Abschätzung  
der Leistungsfähigkeit  
von Schwachstromkontakten -  
Besondere Prüfungen  
(IEC 60947-5-4:2002)

This European Standard was approved by CENELEC on 2003-12-01. CENELEC members are bound to comply with the CEN/CENELEC Internal Regulations which stipulate the conditions for giving this European Standard the status of a national standard without any alteration.

Up-to-date lists and bibliographical references concerning such national standards may be obtained on application to the Central Secretariat or to any CENELEC member.

This European Standard exists in three official versions (English, French, German). A version in any other language made by translation under the responsibility of a CENELEC member into its own language and notified to the Central Secretariat has the same status as the official versions.

CENELEC members are the national electrotechnical committees of Austria, Belgium, Czech Republic, Denmark, Finland, France, Germany, Greece, Hungary, Iceland, Ireland, Italy, Lithuania, Luxembourg, Malta, Netherlands, Norway, Portugal, Slovakia, Spain, Sweden, Switzerland and United Kingdom.

**CENELEC**

European Committee for Electrotechnical Standardization  
Comité Européen de Normalisation Electrotechnique  
Europäisches Komitee für Elektrotechnische Normung

**Central Secretariat: rue de Stassart 35, B - 1050 Brussels**

## Foreword

The text of the International Standard IEC 60947-5-4:2002, prepared by SC 17B, Low-voltage switchgear and controlgear, of IEC TC 17, Switchgear and controlgear, was submitted to the Unique Acceptance Procedure and was approved by CENELEC as EN 60947-5-4 on 2003-12-01.

This European Standard supersedes EN 60947-5-4:1997.

The following dates were fixed:

- latest date by which the EN has to be implemented at national level by publication of an identical national standard or by endorsement (dop) 2004-12-01
- latest date by which the national standards conflicting with the EN have to be withdrawn (dow) 2006-12-01

Annexes designated "normative" are part of the body of the standard.

In this standard, Annexes A and ZA are normative.

Annex ZA has been added by CENELEC.

---

## Endorsement notice

The text of the International Standard IEC 60947-5-4:2002 was approved by CENELEC as a European Standard without any modification.

---

## CONTENTS

INTRODUCTION.....	4
1 Scope and object.....	5
2 Normative references .....	5
3 Definitions and list of symbols used.....	6
3.1 Definitions .....	6
3.2 List of symbols used.....	8
4 General principles .....	9
5 General test method .....	10
6 General characteristics.....	11
6.1 Measurement methods .....	11
6.2 Sequences of operations .....	12
6.3 Electrical characteristics.....	14
6.4 Characteristics of operation.....	15
7 Characterization of defects.....	16
7.1 Basic method .....	16
7.2 Monitoring the load (figure 3) .....	16
8 Ambient conditions .....	16
8.1 Normal conditions .....	16
8.2 Preconditioning .....	17
8.3 Particular conditions.....	17
9 Methods of reporting .....	17
9.1 Failure criterion .....	17
9.2 Reporting the failure rate.....	17
10 Information to be provided in the test report .....	19
Annex A (normative) Information to be supplied by the manufacturer.....	21
Annex ZA (normative) Normative references to international publications with their corresponding European publications .....	24
Bibliography.....	25
Figure 1 – Functional diagram of the testing equipment .....	10
Figure 2 – Typical test circuit for the basic method .....	11
Figure 3 – Test circuit for monitoring a load.....	12
Figure 4 – Sequential diagram with load-switching contacts.....	13
Figure 5 – Sequential diagram without load-switching contacts .....	14
Table 1 – Coefficient $K_C$ for a time-terminated test.....	20

## INTRODUCTION

Control switches may not be suitable for use at very low voltages and therefore it is recommended to seek the advice of the manufacturer concerning any application with a low value of operational voltage, for example, below 100 V a.c. or d.c. (see IEC 60947-5-1, note 2 of 4.3.1.1).

However, the development of electronic systems and programmable controllers in industrial processes increases the use of switching elements in low-voltage circuit control.

It is thus necessary to define how predicational behaviour of contacts in this area should be established (with an acceptable confidence level), by using precise conventional testing methods, down to specified values (such as 2 V, 1 mA; 5 V, 10 mA).

<http://www.china-gauges.com/>

## LOW-VOLTAGE SWITCHGEAR AND CONTROLGEAR –

### Part 5-4: Control circuit devices and switching elements – Method of assessing the performance of low-energy contacts – Special tests

#### 1 Scope and object

This part of IEC 60947 applies to separable contacts used in the utilization area considered, such as switching elements for control circuits.

This standard takes into consideration two rated voltage areas:

- a) above (and including) 10 V (typically 24 V) where contacts are used for switching loads with possible electrical erosion, such as programmable controller inputs;
- b) below 10 V (typically 5 V) with negligible electrical erosion, such as electronic circuits.

This standard does not apply to contacts used in the very low energy area of measurement, for example, sensor or thermocouple systems.

The object of this standard is to propose a method of assessing the performances of low energy contacts giving

- useful definitions;
- general principles of test methods which are to monitor and record the behaviour of contacts at each operation;
- functional bases for the definition of a general testing equipment;
- preferred test values;
- particular conditions for testing contacts intended for specific applications (such as switching of PC inputs);
- information to be given in the test report;
- interpretation and presentation of the test results.

#### 2 Normative references

The following referenced documents are indispensable for the application of this document. For dated references, only the edition cited applies. For undated references, the latest edition of the referenced document (including any amendments) applies.

IEC 60068-1:1988, *Environmental testing – Part 1: General and guidance*  
Amendment 1 (1992)

IEC 60068-2 (all parts), *Environmental testing – Part 2: Tests*

IEC 60605-6:1997, *Equipment reliability testing – Part 6: Tests for the validity of the constant failure rate or constant failure intensity assumptions*

IEC 60947-1:1999, *Low-voltage switchgear and controlgear – Part 1: General rules*<sup>1</sup>  
Amendment 1 (2000)  
Amendment 2 (2001)

IEC 60947-5-1:1997, *Low-voltage switchgear and controlgear – Part 5-1: Control circuit devices and switching elements – Electromechanical control-circuit devices*<sup>2</sup>  
Amendment 1 (1999)  
Amendment 2 (1999)

IEC 61131-2:1992, *Programmable controllers – Part 2: Equipment requirements and tests*

### 3 Definitions and list of symbols used

#### 3.1 Definitions

For the purpose of this part of IEC 60947, the following definitions apply.

In this standard the term “time interval” is expressed as the “number of operating cycles”, as appropriate in definitions.

##### 3.1.1

##### **reliability**

probability that an item can perform a required function, under given conditions, for a given time interval ( $t_1$ ,  $t_2$ )

NOTE 1 It is generally assumed that the item is in a state to perform this required function at the beginning of the time interval.

NOTE 2 The term “reliability” is also used to denote the reliability performance quantified by this probability (see IEC 191-02-06).

[IEV 191-12-01]

##### 3.1.2

##### **contact reliability**

probability that a contact can perform a required function, under given conditions, for a given number of operating cycles

##### 3.1.3

##### **failure**

termination of the ability of an item to perform a required function

NOTE 1 After a failure the item has a fault.

NOTE 2 “Failure” is an event, as distinguished from “fault”, which is a state.

NOTE 3 This concept as defined does not apply to items consisting of software only.

[IEV 191-04-01]

---

<sup>1</sup> A consolidated version of this standard exists.

<sup>2</sup> A consolidated version of this standard exists.



### 3.1.4

#### **defect**

non-fulfilment of an intended requirement or an expectation for an entity, including one concerned with safety

NOTE The requirement or expectation should be reasonable under the existing circumstances.

### 3.1.5

#### **observed failure rate $\lambda_{ob}$**

for a stated period in the life of an item, ratio of the total number of failures in a sample to cumulated observed number of cycles on that sample. The observed failure rate is to be associated with particular and stated numbers of operating cycles (or summation of operating cycles) in the life of the item and with stated conditions

### 3.1.6

#### **assessed failure rate $\lambda_c$**

failure rate of an item determined by a limiting value or values of the confidence interval associated with a stated confidence level, based on the same data as the observed failure rate of nominally identical items

NOTE 1 The source of the data should be stated.

NOTE 2 Results can be accumulated (combined) only when all conditions are similar.

NOTE 3 The assumed underlying distribution of failures against time should be stated.

NOTE 4 It should be stated whether a one-side or a two-side interval is being used.

NOTE 5 Where only one limiting value is given, this is usually the upper limit.

### 3.1.7

#### **constant failure rate period**

that period, if any, in the life of a non-repaired item during which the failure rate is approximately constant

[IEV 191-10-09]

NOTE In reliability engineering, it is often assumed that the failure rate  $\lambda$  is constant, that is that the times to failure are distributed exponentially.

### 3.1.8

#### **controlling unit**

equipment generating commands to run a specified test sequence controlling synchronization and the flow of orders (such as starts, measurements, stops)

### 3.1.9

#### **steady state** (of the contacts after closing)

state of the contact after mechanical stabilization (after operation bounces)

### 3.1.10

#### **load**

device which is to be controlled by the contact under test

### 3.1.11

#### **duty ratio**

ratio, for a given time interval, of the on-load duration to the total time

[IEV 151-04-13]

**3.1.12****contact voltage drop  $U_k$** 

voltage between the contact members in the steady state

**3.1.13****defect contact voltage drop  $U_{kd}$** 

value of the voltage drop for which a defect is registered if it is exceeded for a time more than  $t_d$

**3.1.14****defect time  $t_d$** 

minimum time during which a contact voltage drop greater than  $U_{kd}$  is considered as a defect

**3.1.15****ON voltage  $U_{ON}$** 

minimum voltage necessary for activating the load from the OFF to the ON state

**3.1.16****ON time  $t_{ON}$** 

corresponding minimum duration of the application of voltage  $U_{ON}$  for activating the load from the OFF to the ON state

**3.1.17****OFF voltage  $U_{OFF}$** 

maximum voltage necessary for deactivating the load from the ON to the OFF state

**3.1.18****OFF time  $t_{OFF}$** 

corresponding minimum time to change from the ON to the OFF state when the voltage drops to  $U_{OFF}$  or below

**3.2 List of symbols used**

AX	auxiliary contact (see figure 2)
B	coefficient used for statistical analysis (see table 1)
c	confidence level
C	contact under test (see figure 2)
I	test current
$m_c$	statistical assessed constant mean number of operating cycles to failure (lower limit) at confidence level c ( $m_c = 1/\lambda_c$ )
M	measurement of voltage drop or monitoring the load (see figure 4)
n	number of tested items at the commencement of the test (see 9.2.2)
N	number of operating cycles (see 9.2.2)
$N_i$	number of operating cycles for item i (see 9.2.2)
$N^*$	cumulative number of operating cycles (see 9.2.2)
r	number of failures (see 9.2.2)
$t_b$	time to reach steady-state conditions (see figure 4)
$t_d$	defect time (see 3.1.14)
$t_c$	final time without surveillance before breaking current (see figure 4)
$t_e$	time interval between the opening of AX and C (see figure 5)

$t_i$	initial time without surveillance after initiation of current (see figure 4)
$t_m$	time of measurement of contact voltage drop $U_k$ or monitoring the load (see figure 4)
$t_{OFF}$	OFF time (see 3.1.18)
$t_{ON}$	ON time (see 3.1.16)
$t_p$	time of current flowing (see figure 4)
$t_s$	time of steady state of the test contact (see 3.1.9 and figure 4)
$U$	supply voltage of the test circuit
$U_k$	contact voltage drop (see 3.1.12)
$U_{kd}$	defect contact voltage drop (see 3.1.13)
$U_L$	voltage across the load (see figure 4)
$U_{OFF}$	OFF voltage (see 3.1.17)
$U_{ON}$	ON voltage (see 3.1.16)
$T$	period of the test cycle (see figure 4)
$\lambda$	true constant failure rate
$\lambda_c$	assessed failure rate (upper limit) at confidence level $c$
$\lambda_{ob}$	observed failure rate (calculated from test) (see 3.1.5)

#### 4 General principles

A method of assessing the performances of low-energy contacts by special tests is proposed. As the failures of such contacts are of a random nature, the method is based on a continuous monitoring of the contacts under test.

For the basic method (see 6.1.1), the voltage drop between the terminals of the closed contact (steady state – see 3.1.9) is measured for each operation and compared to a specified threshold.

In the alternative method, the behaviour of the load is monitored at each operating cycle.

The measurement is performed under constant voltage  $U$  (see figures 2 and 3). The contact(s) under test is (are) mounted and connected as in normal service and under ambient conditions as defined in clause 8. The measurement of the voltage drop is made directly on the connecting terminals of the contact(s) or on the connecting terminals of the load (see 6.1.2).

In the basic and alternative methods recommended here (see 6.1.1 and 6.1.2), the contacts under test switch (make and break) the load.

For tests without switching the load, the analysis may be performed on the same equipment. The testing equipment for this purpose should, therefore, be designed accordingly.

It may be possible to test the contact(s) in particular environments (dry heat, dust, damp heat,  $H_2S$ , etc.). Such environments shall be agreed between the user and the manufacturer, and shall be chosen from those defined in the IEC 60068-2 series (see clause 8).

In the basic method, tests are made with direct current. Precautions concerning measurement of low voltage shall be taken (for example, the use of shielded cables).

When the test is performed on a load, care must be taken to avoid voltage drops other than contact voltage drop (use of stabilized power supply).

Any external influence liable to affect the results (such as vibrations) shall be avoided.

## 5 General test method

The equipment used for the test (see figure 1) controls

- the operation of contacts under test;
- the electrical supply for contact circuits;
- the measurement of contact voltage drop for the basic method or the monitoring of the state of the load for the alternative method;
- the detection and recording of defects and failures for each of the contacts under test.

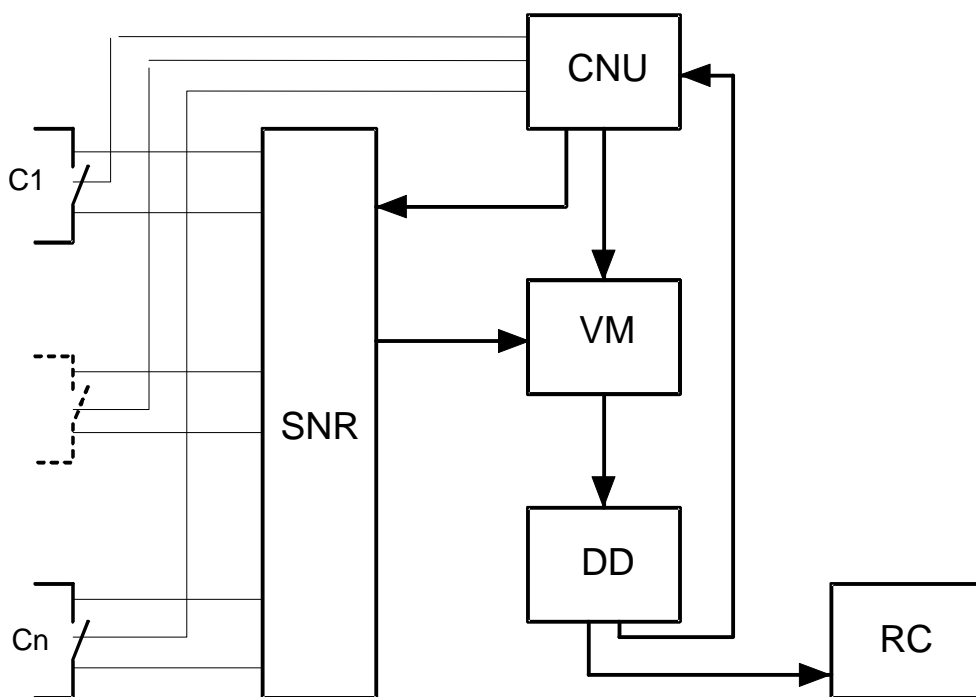

IEC 2432/02

### Key

C1,..., Cn Contacts under test  
 SNR Scanner  
 DD Detection of defects

CNU Controlling unit  
 VM Voltage measuring device  
 RC Recording of results

**Figure 1 – Functional diagram of the testing equipment**

To ensure an adequate statistical estimate of the failure rate, eight or more contacts of the type to be tested shall be tested.

NOTE Where applicable, both make and break contacts should be tested.

The number of operating cycles of the test shall be at least 25 %, and not more than 100 %, of the durability with the number of operating cycles at low energy stated by the manufacturer. Unless otherwise stated, this stated number is the mechanical durability.

Means of verification of the operating sequence, with special attention to the state of the contacts under test, and calibration of measuring devices shall be included in the test equipment.

## 6 General characteristics

### 6.1 Measurement methods

#### 6.1.1 Measurement on the contact (basic method)

The measurement (detection of contact voltage drop) is made directly on the contact terminals according to figure 2.

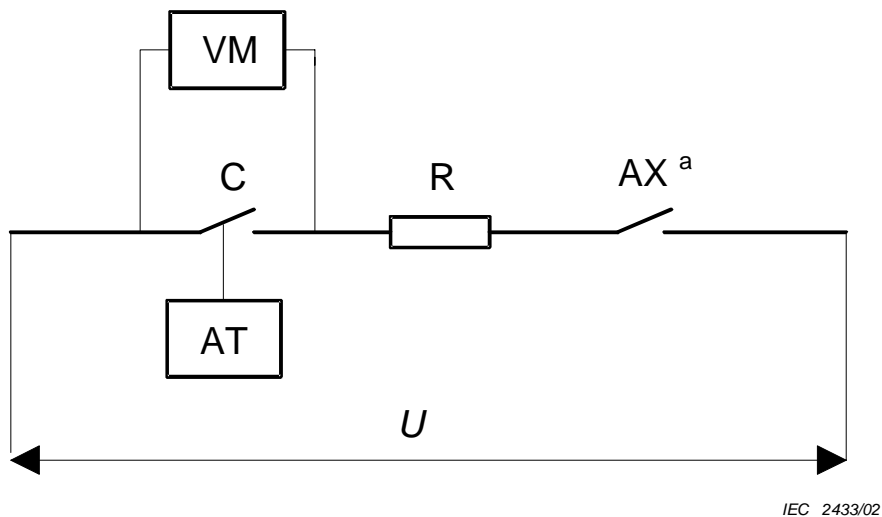

#### Key

C	Contact under test	AX	Auxiliary contact used for making and breaking current when not switching the load by the contact under test
$U$	Supply voltage d.c.	AT	Actuation function of contact under test
R	Resistive load		
VM	Voltage measuring device		

<sup>a</sup> AX shall be chosen with low mechanical bounce and stable contact voltage drop.

**Figure 2 – Typical test circuit for the basic method**

#### 6.1.2 Monitoring the load (alternative method)

In this method the contact is tested by monitoring the behaviour of the load according to figure 3.

This method corresponds to normal service conditions and gives results which depend on the load characteristics. The results can only be compared if the tests are performed on loads with identical characteristics.

The behaviour of the supply voltage has a direct influence on the performance of the load.

Therefore it is necessary to use a stable (better than  $\pm 1\%$ ) uninterruptible power supply (see 6.3.1 for maximum ripple content of supply).

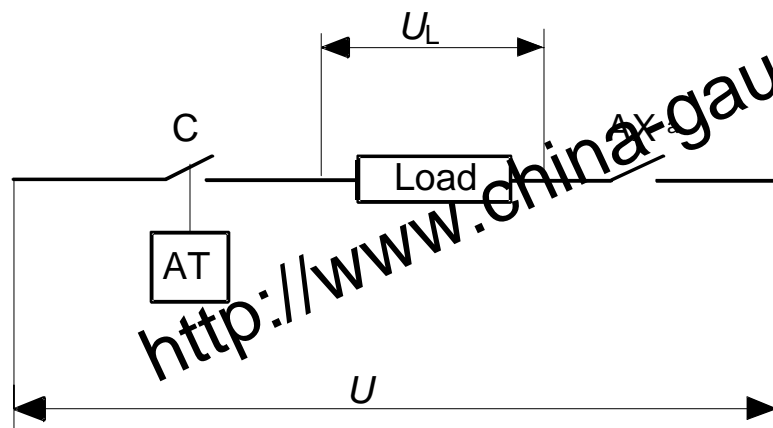

IEC 2434/02

**Key**

C	Contact under test	AT	Actuation function of contact under test
U	Supply voltage (d.c. or a.c.)	AX	Auxiliary contact
$U_L$	Voltage across the load		

NOTE One AX contact may be used for more contacts under test, as long as the AX contact rating is not exceeded, each contact being monitored including an individual resistance load R.

<sup>a</sup> AX shall be chosen with low mechanical bounce and stable contact voltage drop.

**Figure 3 – Test circuit for monitoring a load**

## 6.2 Sequences of operations

For these recommended tests (basic method or alternative method), the contact under test switches the load and AX (see figures 2 and 3) is permanently closed during the test. The sequential diagram is given in figure 4.

For specific applications, the contact under test does not switch the load. An example of a sequential diagram is given in figure 5.

In these diagrams, the represented functions (C, I, etc.) are those indicated in figures 2 and 3. The function M is actually the measurement of the contact voltage drop for the basic method. It can also be the monitoring or the recording of the state of the load in the alternative method.

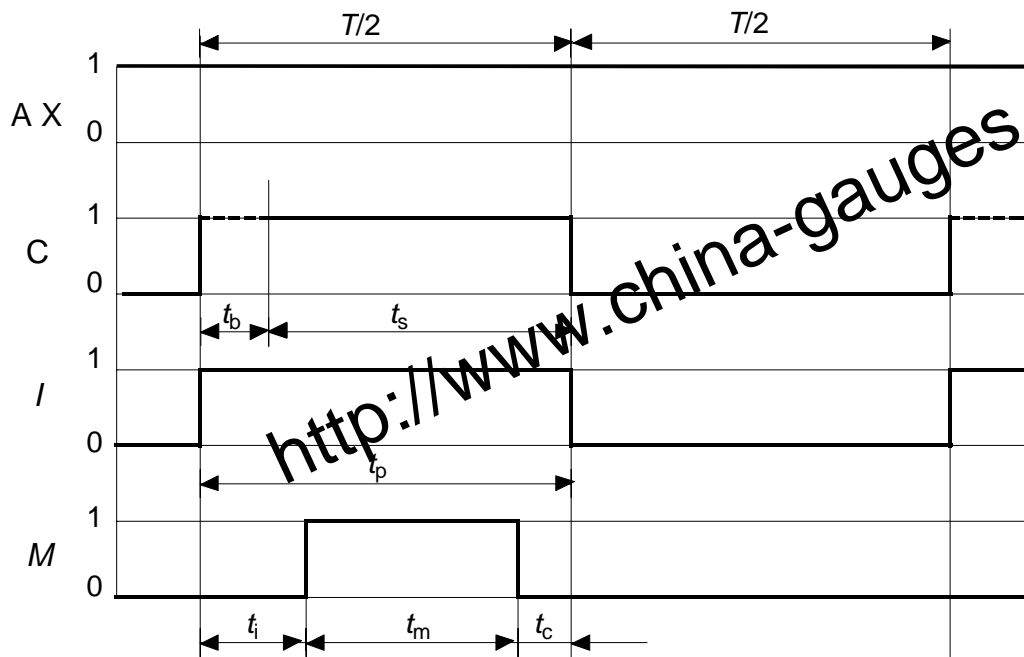

IEC 2435/02

**Key**

C	Contact under test	$t_i$	Initial time without surveillance after initiation of current $t_i \leq 40\%$ of $t_p$ and at least 10 ms
I	Test current	$t_m$	Time of measurement of contact voltage drop ( $U_k$ ), or monitoring of the load
M	Measurement of voltage drop or monitoring of the load	$t_p$	Time of current flowing
T	Period of the test cycle	$t_s$	Time of steady state of the tested contact
AX	Auxiliary contact	$t_b$	Time to reach steady-state conditions (bouncing has ceased) and at least 10 ms
		$t_c$	Final time without surveillance before breaking current (for example, $t_c = 10\%$ of $t_p$ )

**Figure 4 – Sequential diagram with load-switching contacts**

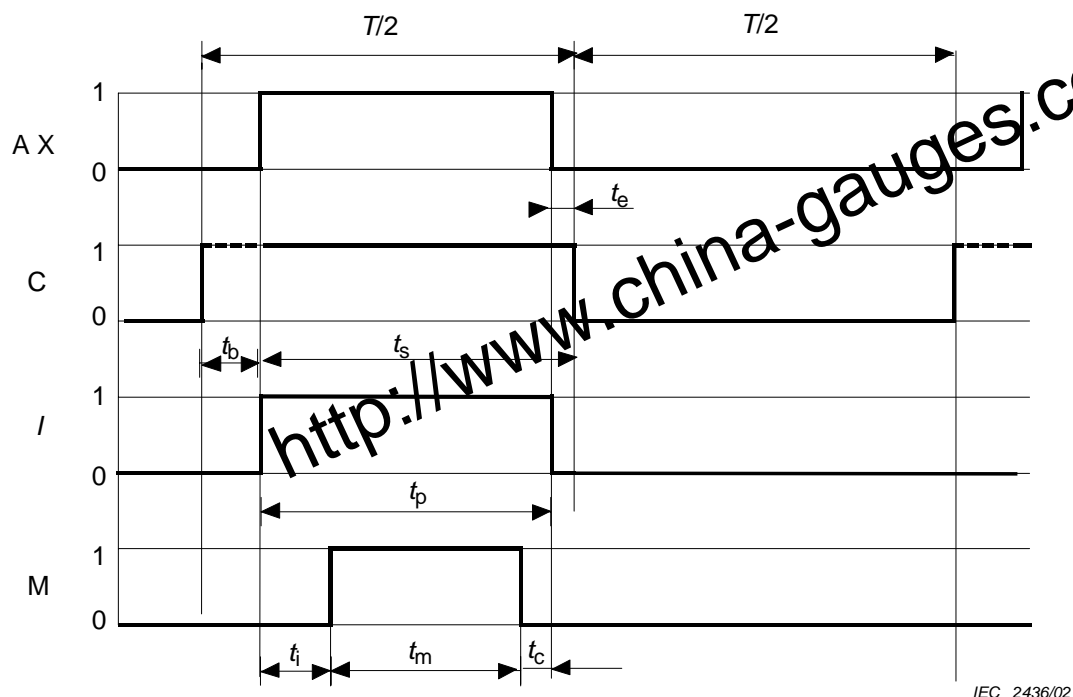
**Key**

C	Contact under test	$t_e$	Time interval between the opening of AX and C
I	Test current	$t_i$	Initial time without surveillance after initiation of current $t_i \leq 40\%$ of $t_p$ and at least 10 ms
M	Measurement of voltage drop or monitoring of the load	$t_m$	Time of measurement of contact voltage drop ( $U_k$ ), or monitoring of the load
T	Period of the test cycle	$t_p$	Time of current flowing
AX	Auxiliary contact	$t_s$	Time of steady state of the tested contact
$t_b$	Time to reach steady-state conditions (bouncing has ceased) and at least 10 ms		
$t_c$	Final time without surveillance before breaking current (for example, $t_c = 10\%$ of $t_p$ )		

**Figure 5 – Sequential diagram without load-switching contacts**

### 6.3 Electrical characteristics

#### 6.3.1 Characteristics of the supply for basic method

##### 6.3.1.1 Supply voltage

The supply voltage for test circuits (see figure 2) shall be

- d.c.  $24\text{ V} \pm 5\%$  (ripple included), or
- d.c.  $5\text{ V} \pm 5\%$  (ripple included).

NOTE When testing contacts, it is recommended to reverse the direction of the current through the contacts at regular intervals during the test. This should be recorded in the test report.



### 6.3.1.2 Current

For the basic method with negligible contact resistance (short-circuited terminals), the prospective current for test shall be chosen from the following values: 1 mA, 5 mA, 10 mA, 100 mA; 10 mA is the preferred value.

The current shall not exceed the rating of the contacts under the stated test conditions.

The tolerance is  $\pm 5\%$  of the nominal value (when setting at the actual voltage  $U$ ).

### 6.3.2 Supply for alternative method

The supply depends on the load requirements. In every case, the stability shall be better than  $\pm 1\%$  of the adjusted voltage (see figure 3).

### 6.3.3 Characteristics of active load

#### 6.3.3.1 General

The load is characterized by the following values:

ON voltage:  $U_{ON}$       ON delay:  $t_{ON}$   
OFF voltage:  $U_{OFF}$       OFF delay:  $t_{OFF}$

The load will be activated (ON state) when  $U_L \geq U_{ON}$  for a time  $t \geq t_{ON}$  and will return to OFF state when  $U_L \leq U_{OFF}$  for a time  $t \geq t_{OFF}$ .

#### 6.3.3.2 Input of programmable controller (PC system as defined in IEC 61131-2)

Manufacturer's name and type designation of the PC system used for the test shall be recorded in the test report.

#### 6.3.3.3 Contactor or relay

As the test corresponds to a practical application, the power supply can be a.c. or d.c. as appropriate.

The load shall be used as recommended by the manufacturer. If a suppressor is used, it shall be mentioned in the test report. The type of suppressor used (diode, varistor, RC link, etc.) shall also be mentioned.

The load, in this case being an electromechanical device, is subject to mechanical wear. Consequently, the load (contactor or relay) shall be replaced before reaching its stated mechanical life.

The manufacturer's name and type designation of the load shall be recorded in the test report.

## 6.4 Characteristics of operation

The operating cycle shall be chosen following 4.3.4.3 of IEC 60947-1, appropriate to the device and load under test.

Duty ratio for the contacts under test: 50 %.

In some cases, an operating machine is necessary for actuating the tested contacts.

Operating conditions of the machine shall be as defined in 8.3.2.1 of IEC 60947-5-1.

## 7 Characterization of defects

### 7.1 Basic method

#### 7.1.1 General

The test equipment shall be adequate to detect contact voltage drops greater than  $U_{kd}$  persisting for a time  $t \geq t_d$ . The value of  $t_d$  required depends on the application and shall be recorded in the test report; preferred values of  $t_d$  are 1 ms and 5 ms.

The value for  $U_{kd}$  depends on the application. Preferred values are: 1 %, 10 %, 25 % of  $U$ .

For a defective operation only one defect shall be counted, even if several defects of conduction (intermittent contact) occur during  $t_m$ .

NOTE The characterization of a defect given in this standard is conventional. In practice, it might be possible that such a defect never causes a malfunction.

#### 7.1.2 Calibration of the detection threshold

For fixed values of  $U$  and  $I$ , a calibration resistor replaces the contact to be tested and is adjusted to obtain  $U_{kd}$ . The detector (or the recorder) is adjusted to operate within the specified tolerances of measurement.

#### 7.1.3 Monitoring (during $t_m$ )

- By analogue measurement: for the measuring time  $t_m$ , see figures 4 and 5.
- By sampling at high frequency: the measuring time  $t_m$  shall be as shown in figures 4 and 5, and the time between two samplings shall be less than  $t_d/2$ .

### 7.2 Monitoring the load (figure 3)

#### 7.2.1 Voltage drop measurement

The first method of monitoring can use the same principle as in 7.1: analogue or sampling measurement of  $U_L$ . In this case, there is a defect when  $U_L < U_{ON}$  for a time  $t \geq t_{OFF}$  (see 6.3.3).

#### 7.2.2 Analysis of the state of the load

This is made by counting the number of operations of the output. In this case, the number of defects to be considered is the difference between the number of contact operations and the number of output changes.

## 8 Ambient conditions

### 8.1 Normal conditions

These are defined in 5.3 of IEC 60068-1, for temperature (15 °C to 35 °C), relative humidity (25 % to 75 %), and pressure (86 kPa to 106 kPa).

## 8.2 Preconditioning

The contacts to be tested should be exposed to the environmental testing conditions, stated in 8.1, for 24 h. If, however, the preconditioning is different from the above, it shall be mentioned in the test report, and a description of the preconditioning procedure shall be added.

## 8.3 Particular conditions

For particular applications, special tests may be required in controlled environments. Such environments should be chosen from IEC 60068-2 series.

## 9 Methods of reporting

### 9.1 Failure criterion

A failure of a contact is considered to have occurred after three defects.

The failure of a contact and the number of operating cycles at the occurrence of the failure for that contact are registered.

The time-terminated test is recommended.

After one failure (three defects), the contact shall not be considered for further statistical evaluation. It may be removed from test and replaced by a new contact whose performance is taken into consideration in the statistical analysis (see 9.2, test with replaced failed item).

### 9.2 Reporting the failure rate

#### 9.2.1 General

In the case where it can be assumed that the failure rate is constant during the test (see IEC 60605-6), the confidence limits which give the assessed values may be derived from the  $\chi^2$  distribution.

For the one-sided interval, at confidence level  $c$ , the upper limit of the failure rate is  $\lambda_c$  for the assessed failure rate, with

$$0 < \lambda < \lambda_c$$

The assessed number of operating cycles to failure is:  $m_c = 1/\lambda_c$

The failure rate is expressed by using the value  $\lambda_c$  at a given confidence level,  $c$ .

The preferred values of the confidence level  $c$  are 60 % and 90 %.

For a time-terminated test, the way of estimating  $\lambda_c$  or  $m_c$  is given below:

- for non-replaced failed items;
- for replaced failed items.

#### 9.2.2 Estimation of $\lambda_c$ when failed items are not replaced

$\lambda_{ob} = (\text{number of failed items})/(\text{total number of operating cycles})$

$$\lambda_{ob} = r/N^*$$

where

$$N^* = N_1 + N_2 + \dots + N_r + (n - r)N$$

$N_1, N_2, \dots, N_r$  are the operating cycles of items failed during the test

$$\lambda_c = K_c / N^*$$

Even when no failure arises during the test, an upper value of the failure rate  $\lambda_c$  can be estimated when using a time-terminated test.

#### EXAMPLE

- 20 contacts under test ( $n = 20$ )
- test duration:  $N = (5 \times 10^6)$  operating cycles (time-terminated test)
- contact No. 1 failed at 100 000 operating cycles
- contact No. 2 failed at 400 000 operating cycles
- contact No. 3 failed at  $(1,5 \times 10^6)$  operating cycles
- contact No. 4 failed at  $(2,5 \times 10^6)$  operating cycles
- contacts No. 5 and No. 6 failed at  $(4 \times 10^6)$  operating cycles
- contact numbers 7 to 20 completed  $(5 \times 10^6)$  operating cycles without failure.

$$n = 20$$

$$r = 6$$

$$\begin{aligned} N^* &= 10^5 + (0,4 \times 10^6) + (1,5 \times 10^6) + (2,5 \times 10^6) + [2 \times (4 \times 10^6)] + [14 \times (5 \times 10^6)] \\ &= 82,5 \times 10^6 \end{aligned}$$

$$\lambda_{ob} = 6 / 82,5 \times 10^6 = 0,7 \times 10^{-7} \text{ failure/operating cycles}$$

At the confidence level of 90 %,  $K_c = 10,55$  (from table 1)

$$\Rightarrow \lambda_c = 10,55 / (82,5 \times 10^6) = 1,3 \times 10^{-7} \text{ failure/operating cycles}$$

or

$$m_c = 7,7 \times 10^6 \text{ operating cycles}$$

#### 9.2.3 Estimation of $\lambda_c$ when failed items are replaced

When an item fails, it is replaced by a new one. All the failures which appear during the test are counted.

$$\lambda_{ob} = r / N^*$$

where

$r$  = total number of failures

$$N^* = n \times N$$

$$\lambda_c = K_c / N^*$$

#### EXAMPLE

Same conditions as in the previous example, that is:

- 20 contacts under test and spare contacts available for replacing any failed ( $n = 20$ )
- test duration:  $N = (5 \times 10^6)$  operating cycles (time-terminated test)

- contact No. 1 failed at  $(0,1 \times 10^6)$  operating cycles. It was replaced by a new one which ran until the end of the test without failure.
- contact No. 2 failed at  $(0,4 \times 10^6)$  operating cycles. It was replaced by a new one which ran until the end of the test without failure.
- contact No. 3 failed at  $(1,5 \times 10^6)$  operating cycles. It was replaced by a new one which failed after  $(3 \times 10^6)$  operating cycles (that is at the  $(4,5 \times 10^6)^{\text{th}}$  operating cycle). It was then replaced by a new contact which ran until the end of the test without failure.
- contact No. 4 failed at  $(2,5 \times 10^6)$  operating cycles. It was replaced by a new one which ran until the end of the test without failure.
- contacts No. 5 and No. 6 failed at  $(4 \times 10^6)$  operating cycles. They were each replaced by a new one which ran until the end of the test without failure.
- contact numbers 7 to 20 completed  $(5 \times 10^6)$  operating cycles without failure.

$$N = 20$$

$$R = 7$$

$$N^* = 20 \times (5 \times 10^6) = 10^8$$

$$\lambda_{\text{ob}} = 7 / 10^8 \quad \lambda_{\text{ob}} = 0,7 \times 10^{-7} \text{ failure/operating cycles}$$

$$\text{At the confidence level of 90 \%,} \quad K_C = 11,75 \text{ (from table 1)}$$

$$\Rightarrow \lambda_C = 11,75 / 10^8 = 1,2 \times 10^{-7} \text{ failure/operating cycles}$$

or

$$m_C = 8,3 \times 10^6 \text{ operating cycles}$$

## 10 Information to be provided in the test report

The test report shall indicate

- chosen normative characteristics for the basic method:  $U$ ,  $I$ ,  $U_{\text{kd}}$ ,  $t_d$ ;
- characteristics of loads when studying on active load:  $U_{\text{ON}}$ ,  $U_{\text{OFF}}$ ,  $t_{\text{ON}}$ ,  $t_{\text{OFF}}$ , etc.;
- wiring and mounting conditions;
- operating conditions: frequency of operations; mean velocity of actuating device if any; number of significant interruptions and their duration (and state of contact, open or closed, during these interruptions); particular ambient conditions;
- when the test is made on active load, the variations of functional characteristics shall be noted (including thermal stabilization). The characteristics (operating time, sensibility, etc.) of counters shall be given.

A recommended tabular form of report is given in annex A.

Table 1 – Coefficient  $K_c$  for a time-terminated test

Number of failures $r$	Value of $K_c$ at confidence level $c$ %	
	$c = 60$ %	$c = 90$ %
0	0,915	2,305
1	2,020	3,890
2	3,105	5,270
3	4,175	6,70
4	5,25	8,00
5	6,3	9,25
6	7,35	10,55
7	8,40	11,75
8	9,45	13,00
9	10,50	14,20
10	11,50	15,40
11	12,55	16,60
12	13,60	17,80
13	14,60	18,95
14	15,65	20,15
15	16,70	21,30
16	17,70	22,45
17	18,75	23,60
18	19,80	24,75
19	20,75	25,90
20	21,85	27,05
21	22,85	28,20
22	23,90	29,30
23	24,90	30,45
24	25,95	31,60

If the number of failures is more than 24, use the formula:  $K_c = 0,25 [(4r+1)^{1/2} + B]^2$   
 where  $B$  has the following values:

- for  $c = 60$  %,  $B = 0,253$
- for  $c = 90$  %,  $B = 1,28$

**Annex A**  
 (normative)

**Information to be supplied by the manufacturer**

<b>Contacts under test</b>
Manufacturer's name: Type designation of contacts: Form of contacts (see figure 4 of IEC 60947-5-1):

<b>Active load (if any)</b>
Nature of the load: Manufacturer's name: Type designation: Mounting conditions: Method of monitoring the load: (for example, counter, digital voltmeter, logical output): <ul style="list-style-type: none"> <li>• operating time:</li> <li>• sensibility:</li> </ul> Load characteristics <ul style="list-style-type: none"> <li>• ON voltage: <math>U_{ON} = \dots\dots\dots V</math></li> <li>• ON time: <math>t_{ON} = \dots\dots\dots ms</math></li> <li>• OFF voltage: <math>U_{OFF} = \dots\dots\dots V</math></li> <li>• OFF time: <math>t_{OFF} = \dots\dots\dots ms</math></li> </ul>

<b>Environment</b>
Normal (5.3 of IEC 60068-1):    yes – no If no, specify:

Type test		
Reference to standards and subclauses	Test description and requirements	Test values and results
6.1.1	Basic method	yes – no
6.1.2	Alternative method	yes – no

Electrical characteristics		
6.3.1.1	Voltage: $U$ if d.c, $U$ inverted:	d.c or a.c yes – no ..... V
6.3.1.2	Current: $I$	..... mA
IEC 60947-1, 4.3.4.3	Operating cycle	..... cycle/hour
7.1	Defect contact voltage drop	$U_{kd}$ ..... V
7.1	Defect time	$t_d$ ..... ms

Mechanical characteristics		
IEC 60947-5-1, 8.3.2.1	Velocity of actuating device, if any (angular velocity for rotary switches)	..... m/s



Characteristics of the test – Results	
Number of tested item at commencement of test	$n$ =.....
Number of operating cycles	$N$ =.....
Replacement of failed contacts	yes – no
Number of failures	$r$ =.....
Cumulative number of operating cycles (see 9.2.2 and 9.2.3)	$N^*$ =.....
Confidence level	$c$ = 60 % 90 %
Coefficient $K_c$ (from table 1)	$K_c$ =.....
Assessed constant failure rate (failure/operating cycles) $\lambda_c = K_c / N^*$	$\lambda_c$ =.....
Assessed number of operations to fail (operating cycles) $m_c = 1 / \lambda_c$	$m_c$ =.....

<http://www.china-gauges.com/>

## Annex ZA (normative)

### Normative references to international publications with their corresponding European publications

This European Standard incorporates by dated or undated reference, provisions from other publications. These normative references are cited at the appropriate places in the text and the publications are listed hereafter. For dated references, subsequent amendments to or revisions of any of these publications apply to this European Standard only when incorporated in it by amendment or revision. For undated references the latest edition of the publication referred to applies (including amendments).

NOTE When an international publication has been modified by common modifications, indicated by (mod), the relevant EN/HD applies.

<u>Publication</u>	<u>Year</u>	<u>Title</u>	<u>EN/HD</u>	<u>Year</u>
IEC 60068-1 + corr. October + A1	1988 1988 1992	Environmental testing Part 1: General and guidance	EN 60068-1	1994
IEC 60068-2	Series	Environmental testing Part 2: Tests	EN 60068-2 HD 323.2	Series Series
IEC 60605-6	1997	Equipment reliability testing Part 6: Tests for the validity of the constant failure rate or constant failure intensity assumptions	-	-
IEC 60947-1 (mod) A1 A2	1999 2000 2001	Low-voltage switchgear and controlgear Part 1: General rules	EN 60947-1 + corr. October A1 A2	1999 1999 2000 2001
IEC 60947-5-1  A1 A2	1997  1999 1999	Part 5-1: Control circuit devices and switching elements - Electromechanical control circuit devices	EN 60947-5-1 + A12  A1 A2	1997 1999  1999 2000
IEC 61131-2	1992	Programmable controllers Part 2: Equipment requirements and tests	EN 61131-2	1994 <sup>1)</sup>

<sup>1)</sup> EN 61131-2:1994 is superseded by EN 61131-2:2003 + corrigendum August 2003, which is based on IEC 61131-2:2003.

## Bibliography

IEC 60050-151:1978, *International Electrotechnical Vocabulary (IEV) – Part 151: Electrical and magnetic devices*

IEC 60050-191:1990, *International Electrotechnical Vocabulary (IEV) – Chapter 191: Dependability and quality of service*  
Amendment 1 (1999)  
Amendment 2 (2002)

<http://www.china-gauges.com/>

## BSI — British Standards Institution

BSI is the independent national body responsible for preparing British Standards. It presents the UK view on standards in Europe and at the international level. It is incorporated by Royal Charter.

### Revisions

British Standards are updated by amendment or revision. Users of British Standards should make sure that they possess the latest amendments or editions.

It is the constant aim of BSI to improve the quality of our products and services. We would be grateful if anyone finding an inaccuracy or ambiguity while using this British Standard would inform the Secretary of the technical committee responsible, the identity of which can be found on the inside front cover. Tel: +44 (0)20 8996 9000. Fax: +44 (0)20 8996 7400.

BSI offers members an individual updating service called PLUS which ensures that subscribers automatically receive the latest editions of standards.

### Buying standards

Orders for all BSI, international and foreign standards publications should be addressed to Customer Services. Tel: +44 (0)20 8996 9001. Fax: +44 (0)20 8996 7001. Email: [orders@bsi-global.com](mailto:orders@bsi-global.com). Standards are also available from the BSI website at <http://www.bsi-global.com>.

In response to orders for international standards, it is BSI policy to supply the BSI implementation of those that have been published as British Standards, unless otherwise requested.

### Information on standards

BSI provides a wide range of information on national, European and international standards through its Library and its Technical Help to Exporters Service. Various BSI electronic information services are also available which give details on all its products and services. Contact the Information Centre. Tel: +44 (0)20 8996 7111. Fax: +44 (0)20 8996 7048. Email: [info@bsi-global.com](mailto:info@bsi-global.com).

Subscribing members of BSI are kept up to date with standards developments and receive substantial discounts on the purchase price of standards. For details of these and other benefits contact Membership Administration. Tel: +44 (0)20 8996 7002. Fax: +44 (0)20 8996 7001. Email: [membership@bsi-global.com](mailto:membership@bsi-global.com).

Information regarding online access to British Standards via British Standards Online can be found at <http://www.bsi-global.com/bsonline>.

Further information about BSI is available on the BSI website at <http://www.bsi-global.com>.

### Copyright

Copyright subsists in all BSI publications. BSI also holds the copyright, in the UK, of the publications of the international standardization bodies. Except as permitted under the Copyright, Designs and Patents Act 1988 no extract may be reproduced, stored in a retrieval system or transmitted in any form or by any means – electronic, photocopying, recording or otherwise – without prior written permission from BSI.

This does not preclude the free use, in the course of implementing the standard, of necessary details such as symbols, and size, type or grade designations. If these details are to be used for any other purpose than implementation then the prior written permission of BSI must be obtained.

Details and advice can be obtained from the Copyright & Licensing Manager. Tel: +44 (0)20 8996 7070. Fax: +44 (0)20 8996 7553. Email: [copyright@bsi-global.com](mailto:copyright@bsi-global.com).