

Safety of laser products —

Part 4: Laser guards

<http://www.china-gauges.com/>

ICS 13.280; 31.260

National foreword

This British Standard is the UK implementation of EN 60825-4:2006+A2:2011. It is identical with IEC 60825-4:2006, incorporating amendments 1:2008 and 2:2011. It supersedes BS EN 60825-4:2006+A1:2008 which is withdrawn.

The start and finish of text introduced or altered by amendment is indicated in the text by tags. Tags indicating changes to IEC text carry the number of the IEC amendment. For example, text altered by IEC amendment 1 is indicated in the text by $\overline{A1}$.

The UK participation in its preparation was entrusted to Technical Committee EPL/76, Optical radiation safety and laser equipment.

A list of organizations represented on this committee can be obtained on request to its secretary.

This publication does not purport to include all the necessary provisions of a contract. Users are responsible for its correct application.

Compliance with a British Standard cannot confer immunity from legal obligations.

This British Standard was published under the authority of the Standards Policy and Strategy Committee on 30 November 2006

© BSI 2011

Amendments/corrigenda issued since publication

Date	Comments
31 May 2010	Implementation of IEC amendment 1:2008 with CENELEC endorsement A1:2008
31 July 2011	Implementation of IEC amendment 2:2011 with CENELEC endorsement A2:2011

English version

Safety of laser products
Part 4: Laser guards
(IEC 60825-4:2006)

Sécurité des appareils à laser
Partie 4: Protecteurs pour lasers
(CEI 60825-4:2006)

Sicherheit von Lasereinrichtungen
Teil 4: Laserschutzwände
(IEC 60825-4:2006)

This European Standard was approved by CENELEC on 2006-10-01. CENELEC members are bound to comply with the CEN/CENELEC Internal Regulations which stipulate the conditions for giving this European Standard the status of a national standard without any alteration.

Up-to-date lists and bibliographical references concerning such national standards may be obtained on application to the Central Secretariat or to any CENELEC member.

This European Standard exists in three official versions (English, French, German). A version in any other language made by translation under the responsibility of a CENELEC member into its own language and notified to the Central Secretariat has the same status as the official versions.

CENELEC members are the national electrotechnical committees of Austria, Belgium, Cyprus, the Czech Republic, Denmark, Estonia, Finland, France, Germany, Greece, Hungary, Iceland, Ireland, Italy, Latvia, Lithuania, Luxembourg, Malta, the Netherlands, Norway, Poland, Portugal, Romania, Slovakia, Slovenia, Spain, Sweden, Switzerland and the United Kingdom.

CENELEC

European Committee for Electrotechnical Standardization
Comité Européen de Normalisation Electrotechnique
Europäisches Komitee für Elektrotechnische Normung

Central Secretariat: rue de Stassart 35, B - 1050 Brussels

Foreword

The text of document 76/342/FDIS, future edition 2 of IEC 60825-4, prepared by IEC TC 76, Optical radiation safety and laser equipment, was submitted to the IEC-CENELEC parallel vote and was approved by CENELEC as EN 60825-4 on 2006-10-01.

This European Standard supersedes EN 60825-4:1997 + A1:2002 + A2:2003.

The following dates were fixed:

- latest date by which the EN has to be implemented at national level by publication of an identical national standard or by endorsement (dop) 2007-07-01
- latest date by which the national standards conflicting with the EN have to be withdrawn (dow) 2009-10-01

Annex ZA has been added by CENELEC.

Endorsement notice

The text of the International Standard IEC 60825-4:2006 was approved by CENELEC as a European Standard without any modification.

Foreword to amendment A1

The text of document 76/383/FDIS, future amendment 1 to IEC 60825-4:2006, prepared by IEC TC 76, Optical radiation safety and laser equipment, was submitted to the IEC-CENELEC parallel vote and was approved by CENELEC as amendment A1 to EN 60825-4:2006 on 2008-09-01.

The following dates were fixed:

- latest date by which the amendment has to be implemented at national level by publication of an identical national standard or by endorsement (dop) 2009-06-01
- latest date by which the national standards conflicting with the amendment have to be withdrawn (dow) 2011-09-01

Annex ZA has been added by CENELEC.

Endorsement notice

The text of amendment 1:2008 to the International Standard IEC 60825-4:2006 was approved by CENELEC as an amendment to the European Standard without any modification.

Foreword to amendment A2

The text of document 76/428/CDV, future amendment 2 to IEC 60825-4:2006, prepared by IEC TC 76, Optical radiation safety and laser equipment, was submitted to the IEC-CENELEC parallel vote and was approved by CENELEC as amendment A2 to EN 60825-4:2006 on 2011-05-03.

Attention is drawn to the possibility that some of the elements of this document may be the subject of patent rights. CEN and CENELEC shall not be held responsible for identifying any or all such patent rights.

The following dates were fixed:

- latest date by which the amendment has to be implemented at national level by publication of an identical national standard or by endorsement (dop) 2012-02-03
- latest date by which the national standards conflicting with the amendment have to be withdrawn (dow) 2014-05-03

Endorsement notice

The text of amendment 2:2011 to the International Standard IEC 60825-4:2006 was approved by CENELEC as an amendment to the European Standard without any modification.

CONTENTS

INTRODUCTION	7
1 Scope.....	8
2 Normative references.....	8
3 Definitions.....	8
4 Laser processing machines.....	10
4.1 Design requirements.....	10
4.2 Performance requirements.....	11
4.3 Validation.....	11
4.4 User information.....	12
5 Proprietary laser guards.....	12
5.1 Design requirements.....	12
5.2 Performance requirements.....	12
5.3 Specification requirements.....	12
5.4 Test requirements.....	13
5.5 Labelling requirements.....	13
5.6 User information.....	14
Annex A (informative) General guidance on the design and selection of laser guards	15
Annex B (informative) Assessment of foreseeable exposure limit (FEL)	17
Annex C (informative) Elaboration of defined terms	24
Annex D (normative) Proprietary laser guard testing	26
Annex E (informative) Guidelines on the arrangement and installation of laser guards	31
Annex F (informative) Guideline for assessing the suitability of laser guards	41
Annex G (informative) Beam delivery systems	70
Annex ZA (normative) Normative references to international publications with their corresponding European publications.....	80
Bibliography	79
Figure B.1 – Calculation of diffuse reflections	18
Figure B.2 – Calculation of specular reflections.....	18
Figure B.3 – Some examples of a foreseeable fault condition	19
Figure B.4 – Four examples of errant laser beams that might have to be contained by a temporary guard under service conditions.....	20
Figure B.5 – Illustration of laser guard exposure during repetitive machine operation.....	21
Figure B.6 – Two examples of assessed duration of exposure.....	22
Figure B.7 – Assessed duration of exposure for a machine with no safety monitoring	23
Figure C.1 – Illustration of guarding around a laser processing machine.....	24
Figure C.2 – Illustration of active laser guard parameters	25
Figure D.1 – Simplified diagram of the test arrangement	27
Figure D.2 – Simplified diagram of the ventilation for the guard under test.....	28

Figure F.1 – Damage resistance of 1 mm thick zinc coated steel sheet derived from 10 s exposure to a defocused beam during experiments using a CW CO ₂ laser	59
Figure F.2 – Damage resistance of 1 mm thick zinc coated steel sheet derived from 100 s exposure to a defocused beam during experiments using a CW CO ₂ laser	59
Figure F.3 – Damage resistance of 2 mm thick zinc coated steel sheet derived from 10 s exposure to a defocused beam during experiments using a CW CO ₂ laser	60
Figure F.4 – Damage resistance of 2 mm thick zinc coated steel sheet derived from 100 s exposure to a defocused beam during experiments using a CW CO ₂ laser	60
Figure F.5 – Damage resistance of 3 mm thick zinc coated steel sheet derived from 10 s exposure to a defocused beam during experiments using a CW CO ₂ laser	61
Figure F.6 – Damage resistance of 3 mm thick zinc coated steel sheet derived from 100 s exposure to a defocused beam during experiments using a CW CO ₂ laser	61
Figure F.7 – Damage resistance of 2 mm thick aluminium sheet derived from 10 s exposure to a defocused beam during experiments using a CW CO ₂ laser	62
Figure F.8 – Damage resistance of 2 mm thick aluminium sheet derived from 100 s exposure to a defocused beam during experiments using a CW CO ₂ laser	62
Figure F.9 – Damage resistance of 1 mm thick stainless steel sheet derived from 10 s exposure to a defocused beam during experiments using a CW CO ₂ laser	63
Figure F.10 – Damage resistance of 1 mm thick stainless steel sheet derived from 100 s exposure to a defocused beam during experiments using a CW CO ₂ laser	63
Figure F.11 – Damage resistance of 6 mm thick polycarbonate sheet derived from 10 s exposure to a defocused beam during experiments using a CW CO ₂ laser	64
Figure F.12 – Damage resistance of 6 mm thick polycarbonate sheet derived from 100 s exposure to a defocused beam during experiments using a CW CO ₂ laser	64
Figure F.13 – Damage resistance of 1 mm thick zinc coated steel sheet derived from 10 s exposure to a defocused beam during experiments using a CW Nd:YAG laser	65
Figure F.14 – Damage resistance of 1 mm thick zinc coated steel sheet derived from 100 s exposure to a defocused beam during experiments using a CW Nd:YAG laser	65
Figure F.15 – Damage resistance of 2 mm thick zinc coated steel sheet derived from 10 s exposure to a defocused beam during experiments using a CW Nd:YAG laser	66
Figure F.16 – Damage resistance of 2 mm thick zinc coated steel sheet derived from 100 s exposure to a defocused beam during experiments using a CW Nd:YAG laser	66
Figure F.17 – Damage resistance of 3 mm thick zinc coated steel sheet derived from 10 s exposure to a defocused beam during experiments using a CW Nd:YAG laser	67

<http://www.china-gauges.com/>

Figure F.18 – Damage resistance of 3 mm thick zinc coated steel sheet derived from 100 s exposure to a defocused beam during experiments using a CW Nd:YAG laser	67
Figure F.19 – Damage resistance of 2 mm thick aluminium sheet derived from 10 s exposure to a defocused beam during experiments using a CW Nd:YAG laser	68
Figure F.20 – Damage resistance of 2 mm thick aluminium sheet derived from 10 s exposure to a defocused beam during experiments using a CW Nd:YAG laser	68
Figure F.21 – Damage resistance of 1 mm thick stainless steel sheet derived from 10 s exposure to a defocused beam during experiments using a CW Nd:YAG laser	69
Figure F.22 – Damage resistance of 1 mm thick stainless steel sheet derived from 100 s exposure to a defocused beam during experiments using a CW Nd:YAG laser	69
Table D.1 – Laser guard eye classification	28
Table F.1 – Application of ALARP	44

<http://www.china-gauges.com/>

INTRODUCTION

At low levels of irradiance or radiant exposure, the selection of material and thickness for shielding against laser radiation is determined primarily by a need to provide sufficient optical attenuation. However, at higher levels, an additional consideration is the ability of the laser radiation to remove guard material – typically by melting, oxidation or ablation processes that could lead to laser radiation penetrating a normally opaque material.

IEC 60825-1 deals with basic issues concerning laser guards, including human access, interlocking and labelling, and gives general guidance on the design of protective housings and enclosures for high-power lasers.

This part of IEC 60825 deals with protection against laser radiation only. Hazards from secondary radiation that may arise during material processing are not addressed.

Laser guards may also comply with standards for laser protective eyewear, but such compliance is not necessarily sufficient to satisfy the requirements of this standard.

Where the term “irradiance” is used, the expression “irradiance or radiant exposure, as appropriate” is implied.

SAFETY OF LASER PRODUCTS –

Part 4: Laser guards

1 Scope

This part of IEC 60825 specifies the requirements for laser guards, permanent and temporary (for example for service), that enclose the process zone of a laser processing machine, and specifications for proprietary laser guards.

This standard applies to all component parts of a guard including clear (visibly transmitting) screens and viewing windows, panels, laser curtains and walls. Requirements for beam path components, beam stops and those other parts of a protective housing of a laser product which do not enclose the process zone are contained in IEC 60825-1.

In addition this part of IEC 60825 indicates:

- a) how to assess and specify the protective properties of a laser guard; and
- b) how to select a laser guard.

2 Normative references

The following referenced documents are indispensable for the application of this document. For dated references, only the edition cited applies. For undated references, the latest edition of the referenced document (including any amendments) applies.

[A1] IEC 60825-1:2007, *Safety of laser products – Part 1: Equipment classification and requirements* **[A1]**

Amendment 1 (1997)

Amendment 2 (2001)

ISO 12100-1:2003, *Safety of machinery – Basic concepts, general principles for design – Part 1: Basic terminology, methodology*

ISO 12100-2:2003, *Safety of machinery – Basic concepts, general principles for design – Part 2: Technical principles and specifications*

ISO 11553-1:2005, *Safety of machinery – Laser processing machines – Safety requirements*

[A1] ISO 14121-1:2007, *Safety of machinery – Risk assessment – Part 1: Principles*

ISO 13849-1:2006, *Safety of machinery – Safety-related parts of control systems – Part 1: General principles for design* **[A1]**

3 Definitions

For the purpose of this part of IEC 60825, the following definitions apply in addition to the definitions given in IEC 60825-1.

3.1

active guard protection time

for a given laser exposure of the front surface of an active laser guard, the minimum time, measured from the issue of an active guard termination signal, for which the active laser guard can safely prevent laser radiation accessible at its rear surface from exceeding the class 1 AEL

3.2

active guard termination signal

the signal issued by an active guard in response to an excess exposure of its front surface to laser radiation and which is intended to lead to automatic termination of the laser radiation

NOTE The action of a safety interlock becoming open circuit is considered a "signal" in this context.

3.3

active laser guard

a laser guard which is part of a safety-related control system. The control system generates an active guard termination signal in response to the effect of laser radiation on the front surface of the laser guard

3.4

foreseeable exposure limit

FEL

the maximum laser exposure on the front surface of the laser guard, within the maintenance inspection interval, assessed under normal and reasonably foreseeable fault conditions

3.5

front surface

the face of the laser guard intended for exposure to laser radiation

3.6

laser guard

a physical barrier which limits the extent of a danger zone by preventing laser radiation accessible at its rear surface from exceeding the class 1 AEL

3.7

laser processing machine

a machine which uses a laser to process materials and is within the scope of ISO 11553-1

3.8

laser termination time

the maximum time taken, from generation of an active guard termination signal, for the laser radiation to be terminated

NOTE Laser termination time does not refer to the response of an active laser guard but to the response of the laser processing machine, in particular the laser safety shutter.

3.9

maintenance inspection interval

the time between successive safety maintenance inspections of a laser guard

3.10

passive laser guard

a laser guard which relies for its operation on its physical properties only

3.11

process zone

the zone where the laser beam interacts with the material to be processed

3.12

proprietary laser guard

a passive or active laser guard, offered by its manufacturer as a guard with a specified protective exposure limit

3.13

protective exposure limit

PEL

the maximum laser exposure of the front surface of a laser guard which is specified to prevent laser radiation accessible at its rear surface from exceeding the class 1 AEL

NOTE 1 In practice, there may be more than one maximum exposure.

NOTE 2 Different PELs may be assigned to different regions of a laser guard if these regions are clearly identifiable (for example a viewing window forming an integral part of a laser guard).

3.14

rear surface

any surface of a laser guard that is remote from the associated laser radiation and usually accessible to the user

3.15

reasonably foreseeable

an event (or condition) when it is credible and its likelihood of occurrence (or existence) cannot be disregarded

3.16

safety maintenance inspection

documented inspection performed in accordance with manufacturer's instructions

3.17

temporary laser guard

a substitute or supplementary active or passive laser guard intended to limit the extent of the danger zone during some service operations of the laser processing machine

4 Laser processing machines

This clause specifies the requirements for laser guards that enclose the process zone and are supplied by the laser processing machine manufacturer.

4.1 Design requirements

A laser guard shall satisfy ISO 12100-2 with respect to the general requirements for guards and also the more specific requirements with regard to its location and method of fixture. In addition, the following specific laser requirements shall be met.

4.1.1 General requirements

A laser guard, in its intended location, shall not give rise to any associated hazard at or beyond its rear surface when exposed to laser radiation up to the foreseeable exposure limit.

NOTE 1 Examples of associated hazards include: high temperature, the release of toxic materials, fire, explosion, electricity.

NOTE 2 See Annex B for assessment of foreseeable exposure limit.

4.1.2 Consumable parts of laser guards

Provision shall be made for the replacement of parts of a laser guard prone to damage by laser radiation.

NOTE An example of such a part would be a sacrificial or interchangeable screen.

4.2 Performance requirements

4.2.1 General

When the front surface of a laser guard is subjected to exposure to laser radiation at the foreseeable exposure limit, the laser guard shall prevent laser radiation accessible at its rear surface from exceeding the class 1 AEL at any time over the period of the maintenance inspection interval. For automated laser processing machines, the minimum value of the maintenance inspection interval shall be 8 h.

This requirement shall be satisfied over the intended lifetime of the laser guard under expected conditions of operation.

NOTE 1 This requirement implies both low transmission of laser radiation and resistance to laser-induced damage.

NOTE 2 Some materials may lose their protective properties due to ageing, exposure to ultraviolet radiation, certain gases, temperature, humidity and other environmental conditions. Additionally, some materials will transmit laser radiation under high-intensity laser exposure, even though there may be no visible damage (i.e. reversible bleaching).

4.2.2 Active laser guards

- a) The active guard protection time shall exceed the laser termination time up to the foreseeable exposure limits.
- b) The generation of an active guard termination signal shall give rise to a visible or audible warning. A manual reset is required before laser emission can recommence.

NOTE See Annex C.2 for an elaboration of terms.

4.3 Validation

If the laser processing machine manufacturer chooses to make a laser guard, the manufacturer shall confirm that the guard complies with the design requirements of 4.1 and can satisfy the performance requirements set out in 4.2.

NOTE See Annex A for guidance on the design and selection of laser guards.

4.3.1 Validation of performance

4.3.1.1 The complete laser guard, or an appropriate sample of the material of construction of the laser guard, shall be tested at each FEL identified.

NOTE 1 A table of predetermined PELs for common combinations of lasers and guarding materials, together with suitable testing procedures shall be issued as an informative annex in a future amendment to this standard. This could provide a simple alternative to direct testing for the majority of cases.

NOTE 2 See Annex B for the assessment of FEL.

4.3.1.2 For testing purposes, the FEL exposure shall be achieved either:

- a) by calculating or measuring the exposure and reproducing the conditions; or
- b) without quantifying the FEL, by creating the machine conditions under which the FEL is produced.

The condition of the laser guard or sample shall be such as to replicate those physical conditions of the front surface permitted within the scope of the routine inspection instructions and within the service life of the guard, which minimize the laser radiation protective properties of the laser guard (for example wear and tear and surface contamination) (see 4.4.2).

4.4 User information

4.4.1 The manufacturer shall document and provide to the user the maintenance inspection interval for the laser guard, and details of inspection and test procedures, cleaning, replacement or repair of damaged parts, together with any restrictions of use.

4.4.2 The manufacturer shall document and provide to the user instructions that after any actuation of the safety control system of an active guard, the cause shall be investigated, checks shall be made for damage, and the necessary remedial action to be taken before resetting the control system.

5 Proprietary laser guards

This clause specifies the requirements to be satisfied by suppliers of proprietary laser guards.

5.1 Design requirements

A proprietary laser guard shall not create any associated hazard at or beyond its rear surface when exposed to laser radiation up to the specified PEL when used as specified in the user information (see 5.6).

5.2 Performance requirements

The accessible laser radiation at the rear surface of the laser guard shall not exceed the class 1 AEL when its front surface is subjected to laser radiation at the specified PEL. For an active laser guard, this requirement shall apply to laser radiation accessible over the period of the active guard protection time, measured from the moment an active guard termination signal is issued.

This requirement shall be satisfied over the intended lifetime of the guard under expected service conditions.

5.3 Specification requirements

The full specification of a PEL shall include the following information:

- a) the magnitude and variation with time of irradiance or radiant exposure at the front surface of the laser guard (in units of Wm^{-2} or Jm^{-2} respectively), specifying any upper limit to the area of exposure;
- b) the overall duration of exposure under these conditions;
- c) the wavelength for which this PEL applies;
- d) the angle of incidence and (if relevant) the polarization of the incident laser radiation;

- e) any minimum dimensions to the irradiated area (for example as might apply to an active laser guard with discrete sensor elements so that a small diameter laser beam could pass through the guard undetected);
- f) for an active laser guard, the active guard protection time.

NOTE 1 See Clause B.1 for an elaboration of terms.

NOTE 2 In all cases, a range or set of values can be stated rather than a single value.

NOTE 3 A graphical form of presentation is acceptable (for example irradiance vs. duration with all other parameters constant).

5.4 Test requirements

5.4.1 General

Testing shall be performed using the complete laser guard or an appropriate sample of the material used to construct the guard. In either case, the condition of the guard or sample shall be such as to replicate or exceed the worst permissible physical condition of the front surface, including reduced surface reflection and damage permitted within the scope of the routine maintenance instructions (see 5.6).

The front surface irradiation shall be either as specified by the PEL or, in the case of sample testing, as specified in 5.4.2 below.

When the front surface is subjected to the PEL exposure conditions, the accessible laser radiation measured at the rear surface of the laser guard shall not exceed the class 1 AEL (tests as prescribed in Clause 8 of 60825-1). This requirement applies over the exposure duration specified in the PEL or, in the case of an active guard, over the specified active guard protection time measured from the moment an active guard termination signal is issued.

NOTE In cases where materials opaque at the laser wavelength(s) are used (for example metals), the transmitted radiation will only rise to the class 1 AEL when complete (or almost complete) physical removal of material along a path through to the rear surface has been achieved. In such cases, the rise from zero transmission to a value greatly in excess of the class 1 AEL will therefore be rapid, and sensitive radiation detectors will not be required.

5.4.2 Sample testing

Sample guard testing shall be performed by irradiating the front surface of the guard material using the procedure and methodology as specified in Annex D.

5.5 Labelling requirements

5.5.1 All labelling shall be placed on the rear surface of the guard.

5.5.2 The rear surface of the guard shall be clearly identified if the orientation of the guard is important.

5.5.3 If only part of the front surface of the guard is a laser guard, this area shall be clearly identified by a bold coloured outline and words to indicate the outer boundary of the laser guard.

5.5.4 The labelling shall state the full PEL specification.

5.5.5 The manufacturer's name, the date and place of manufacture according to ISO 11553-1, and a statement of compliance with this standard shall be provided.

5.6 User information

In addition to the specifications listed in 5.3, the following information shall be supplied to the user by the manufacturer of a proprietary laser guard:

- a) a description of the permitted uses of the laser guard;
- b) a description of the form of mounting and connection of the laser guard;
- c) information on the installation of the laser guard – for active laser guards this shall include interface and supply requirements for the guard;
- d) maintenance requirements, including for example details of inspection and test procedures, cleaning, replacement or repair of damaged parts;
- e) instructions, that after any actuation of the safety control system of an active guard, the cause shall be investigated, checks shall be made for damage, and the necessary remedial action to be taken before resetting the control system;
- f) the labels in 5.5 and their locations. If only part of the front surface of the guard is a laser guard, this area shall be identified;
- g) a statement of compliance with this standard.

Annex A
(informative)

General guidance on the design and selection of laser guards

A.1 Design of laser guards

A.1.1 Passive laser guards

Examples of a passive laser guard include the following.

- a) A metal panel relying on thermal conduction, if necessary enhanced by forced air or water cooling, to maintain the surface temperature below its melting point under normal and reasonably foreseeable fault conditions.
- b) A transparent sheet, opaque at the laser wavelength, which is unaffected by low value of laser exposure under normal operation of the laser processing machine.

A.1.2 Active laser guards

Examples of an active laser guard include the following.

- a) A guard, with discrete embedded thermal sensors, which detects overheating.

NOTE The spacing between sensors should be considered in relation to the minimum dimensions of an errant laser beam.

- b) A laser guard comprising two panels between which is contained a pressurized liquid or gaseous medium in combination with a pressure-sensing device capable of detecting the pressure drop following perforation of the front surface.

A.1.3 Hazard indication (passive guards)

Visible indication of exposure of the laser guard to hazardous amounts of laser radiation should be provided where feasible (for example by adding a layer of an appropriate paint on both sides of the laser guard).

A.1.4 Power supply (active guards)

If power is required for the proper functioning of an active guard, its supply should be arranged so that laser operation is not possible in the absence of such power.

A.2 Selection of laser guards

A simple selection process is as follows:

- a) identify the preferred position for the laser guard and estimate the FEL at this position. Annex B gives guidance on the estimation of FEL values;

- b) if necessary, minimize the FEL under fault conditions, preferably by including automatic monitoring in the machine which will detect the fault conditions and limit the exposure time. Examples of alternatives include the following:
- ensure that the laser guard is sufficiently far away from beam focus produced by focusing optics;
 - install vulnerable parts of laser guard (such as viewing windows) away from regions that could be exposed to high irradiance;
 - move the laser guard farther away from the laser process zone;
 - require in the essential servicing documentation for temporary laser guards, additions such as:
 - one or more persons to be present to supervise the condition of the front surface of the laser guard, to reduce the assessed exposure duration of a passive guard;
 - a hold-to-operate controller to be used by the person(s) supervising the condition of the front surface of the laser guard, to reduce the assessed exposure duration of a passive guard;
 - additional local temporary guarding, apertures and beam dumps to be employed, to absorb any powerful errant laser beams;
 - the danger zone to be bounded by errant beam warning devices and the guard placed beyond this zone to reduce the assessed exposure duration;
 - incorporate in the design of the machine, when using temporary laser guards, beam control features to facilitate improved laser beam control during servicing operations, such as:
 - holders for precise location of additional beam forming components (for example turning mirrors) required during servicing;
 - mounts which allow only limited scope for beam steering.

Three options then follow. The order below does not indicate a preference.

A.2.1 Option 1: passive laser guard

This is the simplest option.

NOTE Design and quality control are particularly important considerations where the absorption at the laser wavelength is dominated by a minority additive, such as a dye in a plastic. In such cases, where the manufacturer of the material does not specify the concentration of the absorber or the material optical attenuation at the laser wavelength, samples from the same batch of the material should first be tested as described in 4.3.1.

A.2.2 Option 2: active laser guard

If the FEL cannot be reduced to a value where common guarding materials provide adequate protection in the form of a passive laser guard, an active laser guard can always be used.

A.2.3 Option 3: proprietary laser guard

A proprietary laser guard can be used if the assessed FEL values are less than the PEL values quoted by the laser guard manufacturer.

Annex B
(informative)

Assessment of foreseeable exposure limit (FEL)

B.1 General

FEL values may be assessed either by measurement or by calculation (see below).

The standard ISO 14121 provides a general methodology for risk assessment. The assessment should include consideration of cumulative exposure in normal operation (for example during each part processing cycle of the machine) over the maintenance inspection interval.

From this assessment, the most demanding combinations of irradiation, area of exposure and exposure duration should be identified. It is quite likely that several FELs will be identified; for example one condition may maximize the duration of exposure at a relatively low irradiance, while another may maximize the irradiance over a shorter duration of exposure.

The full specification of an FEL comprises the following information.

a) The maximum irradiance at the front surface of the laser guard.

NOTE Irradiance is expressed as the total power or energy divided by the area of the front surface of the guard, or specified limited area, as appropriate.

b) Any upper limit to the area of exposure of the front surface at this level of irradiance.

NOTE No limit to the area would be appropriate for protection against scattered laser radiation while an upper limit to the exposed area would be appropriate for direct exposure to laser beams.

c) The temporal characteristics of the exposure, i.e. whether continuous wave or pulsed laser radiation, and if the latter, then the pulse duration and pulse repetition frequency.

d) The full duration of exposure.

NOTE See Clause B.4 for an elaboration of this term.

e) The wavelength of the radiation.

f) The angle of incidence and (if relevant) the polarization of the radiation.

NOTE 1 Stipulation of angle of incidence is particularly important for laser guards exploiting interference layers to reflect impinging laser radiation.

NOTE 2 CAUTION: At Brewster's angle of incidence "p" polarized radiation is strongly coupled into the surface of the guard.

g) Any minimum dimensions to the irradiated area (for example as might apply to an active laser guard with discrete sensor elements so that a small diameter laser beam could pass through the laser guard undetected).

h) For an active laser guard, the active guard protection time.

B.2 Reflection of laser radiation

B.2.1 Diffuse reflections

Assuming a Lambertian reflector with 100 % reflectivity

$$E_A = \frac{P_o}{\pi} \cdot \frac{\cos\theta}{R^2} \cdot \cos\varphi$$

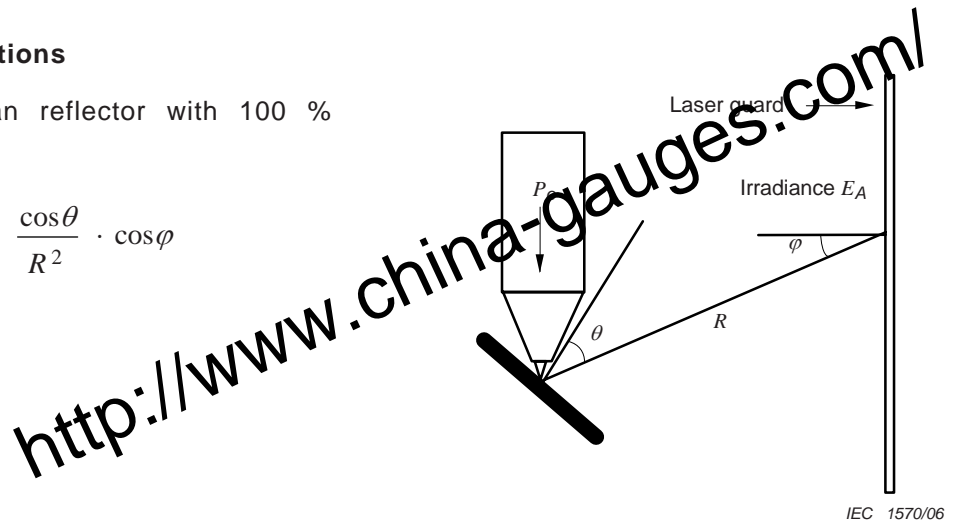

IEC 1570/06

Figure B.1 – Calculation of diffuse reflections

B.2.2 Specular reflections

It is difficult to generalize for the case of specular reflections.

For a circularly symmetric laser beam with a Gaussian distribution, power P_o and diameter d_{63} at the focusing lens, focal length f , the maximum irradiance (at the centre of the Gaussian distribution) in a normal plane distance R from the focus is:

$$E_{AA'} = \frac{4P_o\rho}{\pi d_{63}^2} \left(\frac{f}{R}\right)^2$$

where ρ is the reflectivity of the workpiece surface.

CAUTION: Certain curved surfaces may increase the reflection hazard.

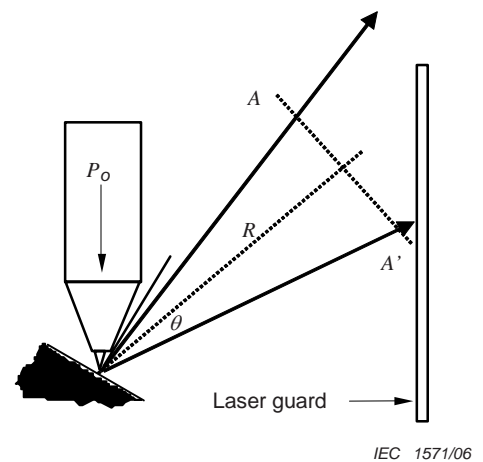

IEC 1571/06

Figure B.2 – Calculation of specular reflections

B.3 Examples of assessment conditions

FELs should be assessed for the worst reasonably foreseeable combination(s) of available laser parameters, workpiece materials, geometry and processes likely to be encountered during normal operation (IEC/TR 60825-14 provides guidance for users).

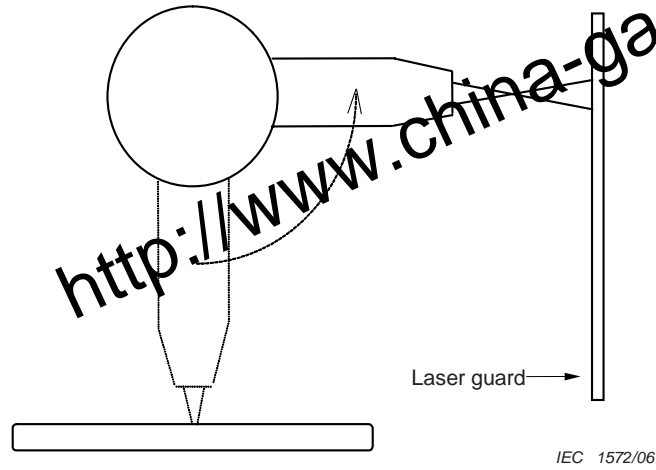

Figure B.3a – Software failure

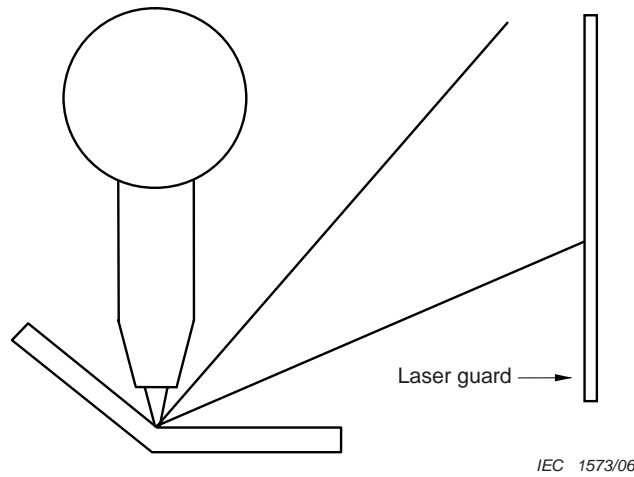

Figure B.3b – Workpiece bends or is inadequately clamped

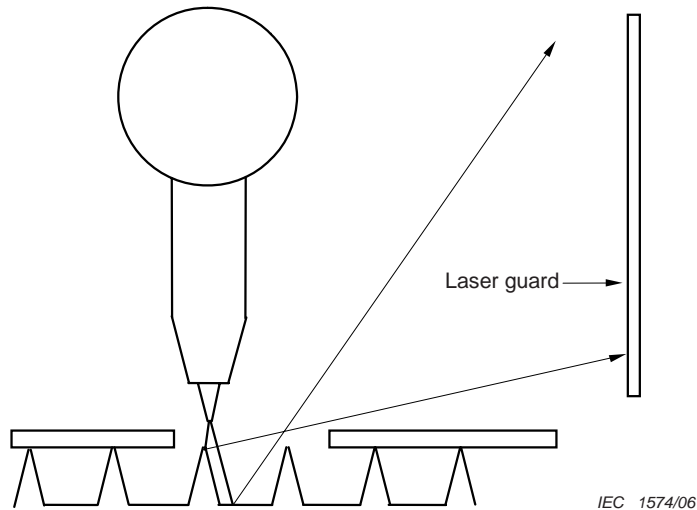

Figure B.3c – Workpiece missing

Figure B.3 – Some examples of a foreseeable fault condition

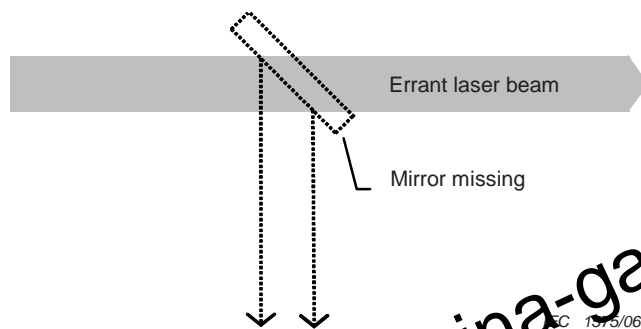

Figure B.4a – Laser is operated with tuning mirror missing

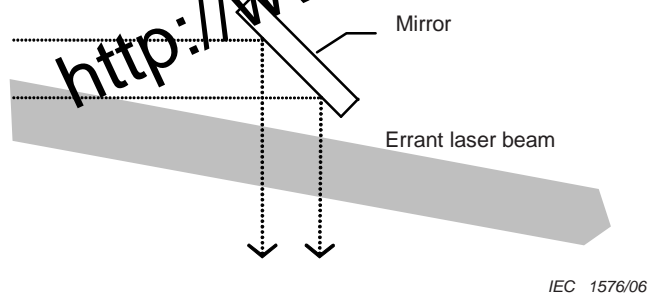

Figure B.4b – Beam displaced off mirror during alignment procedure

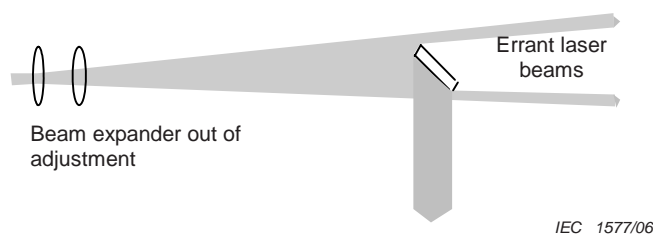

Figure B.4c – Beam expands beyond range of optics

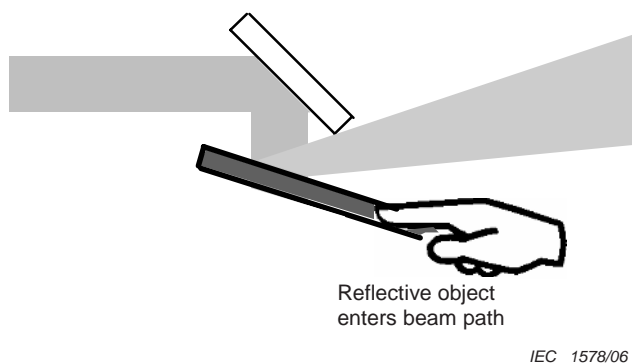

Figure B.4d – Reflective objects intercept laser beam

Figure B.4 – Four examples of errant laser beams that might have to be contained by a temporary guard under service conditions

B.4 Exposure duration

B.4.1 Normal operation

The exposure of a guard to laser radiation during fault-free operation may comprise exposures to low levels of reflected, scattered and transmitted radiation which are repeated on each machine cycle. In this case, the assessed FEL for fault-free operation would encompass the variation in irradiance of the guard during the cycle, repeated for the maximum number of machine cycles within a safety maintenance inspection interval.

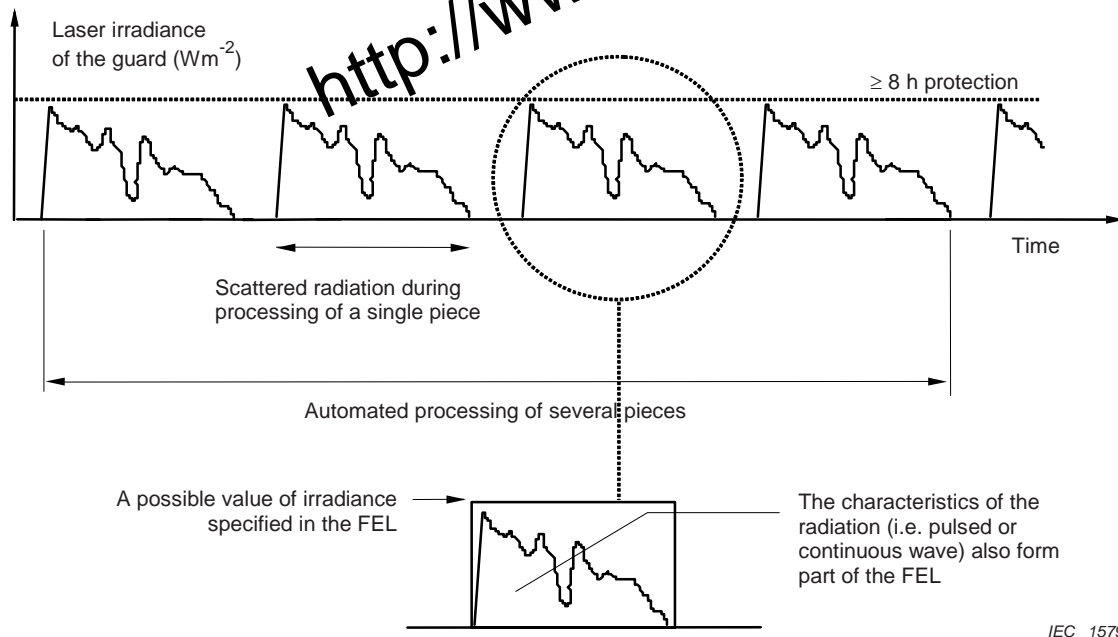

Figure B.5 – Illustration of laser guard exposure during repetitive machine operation

B.4.2 Fault Conditions

A safety control system involving some form of machine monitoring can reduce the time for which the guard must safely contain the radiation hazard under fault conditions. Two examples are given below.

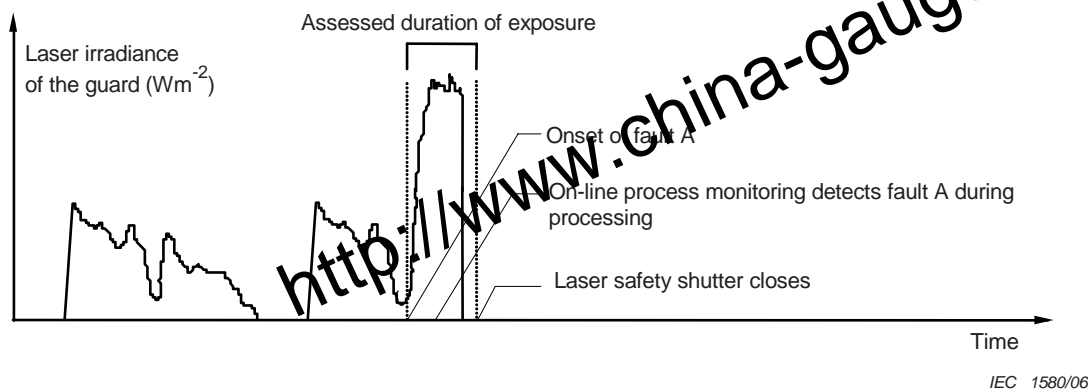

Figure B.6a – Shut-down with on-line machine safety monitoring

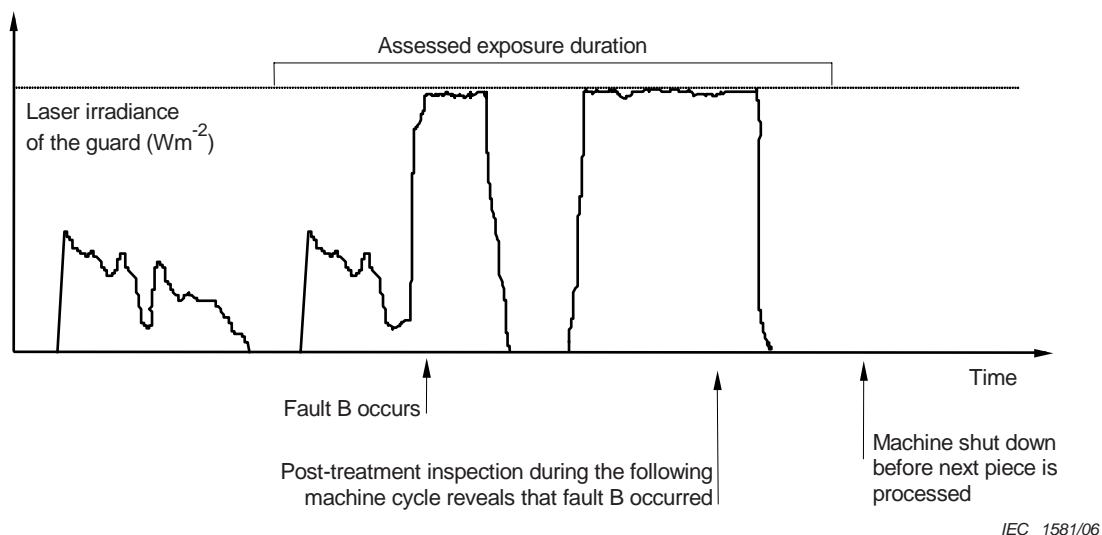

Figure B.6b – Shut-down with off-line machine safety monitoring

Figure B.6 – Two examples of assessed duration of exposure

For reasonably foreseeable fault conditions which are not detected by some safety-related control system, the assessed duration of exposure is the full safety maintenance inspection interval.

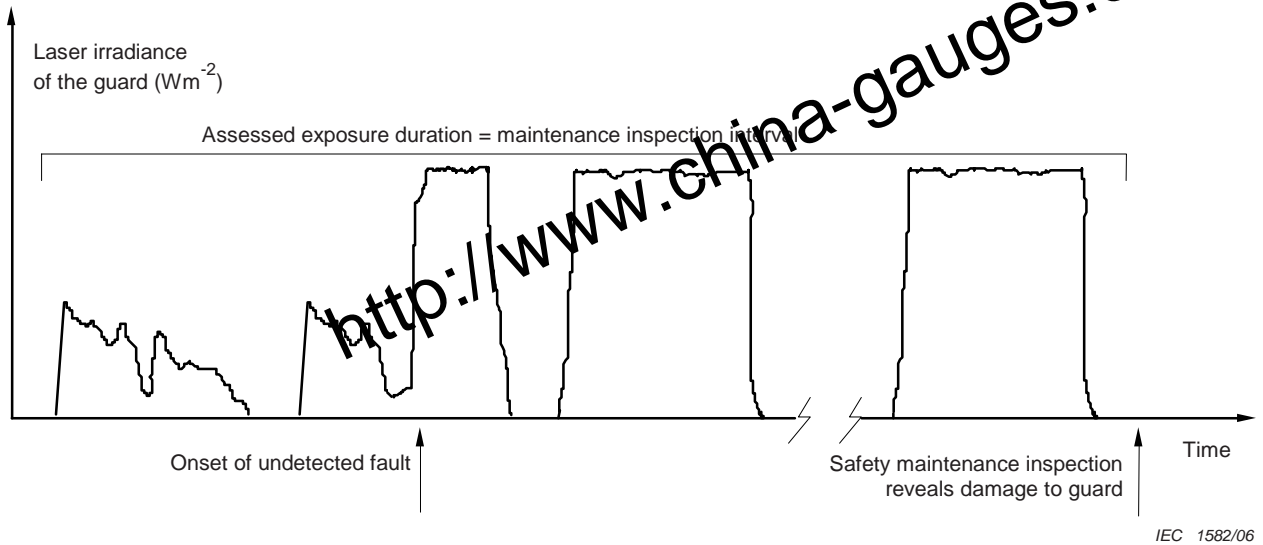

Figure B.7 – Assessed duration of exposure for a machine with no safety monitoring

B.4.3 Servicing operations

The factors which directly affect the time to laser termination measured from the onset of exposure of a temporary guard during servicing operations include:

- the use of a pre-set laser-on time;
- the degree of control over fault conditions;
- provision of persons to supervise the condition of the guard (passive guards);
- provision of a hold-to-operate controller;
- degree of warning provided by the response of the guard to excessive laser exposure (passive guards);
- degree of concealment of the front surface of the guard (passive guards);
- total area of guard to be supervised (passive guards);
- degree of training of service personnel.

A risk assessment should be performed to identify hazardous situations and to assess the foreseeable exposure level. Where human intervention is required to limit the duration of exposure of a temporary guard, a value of not less than 10 s should be used. All reasonably practicable engineering and administrative control measures should be implemented to reduce reliance on temporary screens to provide protection.

B.5 Reference document

ISO 14121:1999, *Safety of machinery – Principles of risk assessment*

Annex C (informative)

Elaboration of defined terms

C.1 Distinction between FEL and PEL

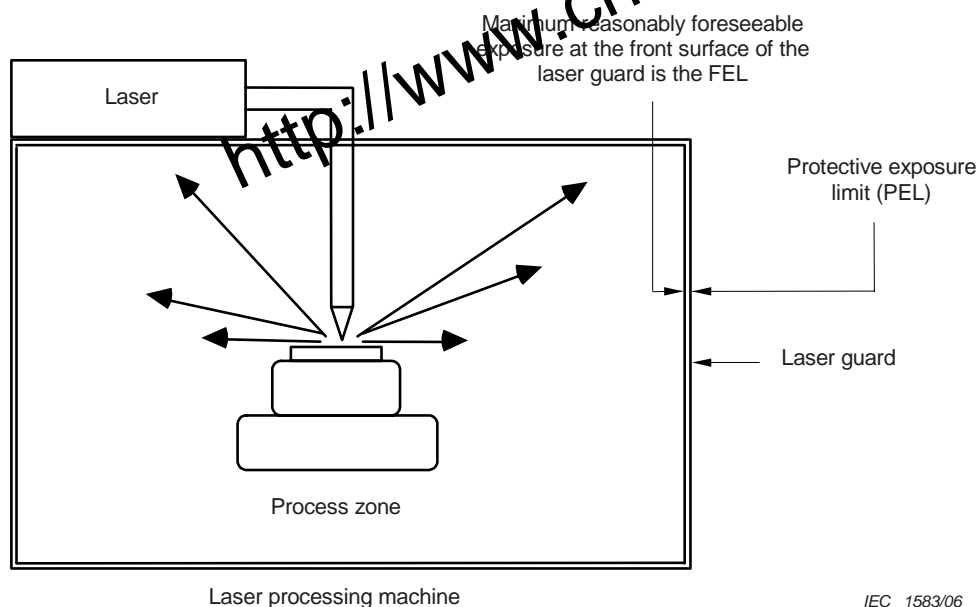

Figure C.1 – Illustration of guarding around a laser processing machine

The foreseeable exposure limit (FEL) at a particular location where a laser guard is to be sited is the maximum exposure estimated by the manufacturer of the laser processing machine, assessed under normal and reasonably foreseeable fault conditions. The FEL value defines the minimum value of the protective exposure limit (PEL) of a laser guard that can be used at that location.

The PEL indicates the capability of a laser guard to protect against incident laser radiation. The manufacturer of the laser processing machine shall perform tests to confirm the adequacy of the laser guards. This can be accomplished by direct testing, or by determining the PEL of the guard, or by purchasing a proprietary laser guard for which the PEL is specified.

C.2 Active guard parameters

An active guard has two essential components:

- a physical barrier, highly attenuating at the laser wavelength, to act as a passive laser guard for low levels of laser radiation (for example diffusely scattered radiation) and to resist the penetration of hazardous levels of incident radiation for a limited (short) time only;

- b) a safety control system which incorporates a sensor that detects hazardous levels of incident laser radiation either directly or indirectly (for example by measuring temperature or by detecting some other effect induced by the laser radiation on some part of the laser guard) and then issues a signal to terminate laser emission (for example by breaking the safety interlock chain, thus switching off the laser source, or by closing a safety shutter).

Laser guards will frequently be subject to low values of laser irradiance during normal operation of a laser processing machine. Since the guard is not threatened by such radiation, the sensor should not react. Instead, the sensor should be set to react only to incident laser radiation that exceeds a threshold value at which the integrity of the laser guard is threatened. There is a time delay between the incident laser radiation exposure exceeding the threshold value and the moment when an active guard termination signal is produced by an active laser guard. Similarly, there is a time delay, termed the laser termination time, between the production of the active guard termination signal and the moment when the laser radiation is terminated.

To satisfy the requirements of this standard it is essential that

[laser termination time] is less than [active guard protection time]

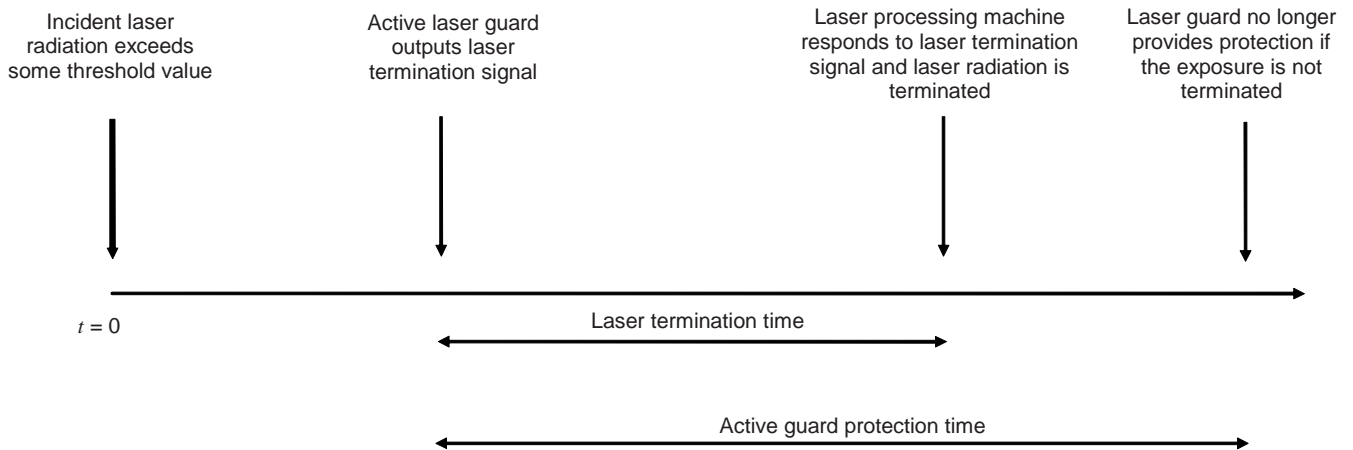

IEC 1584/06

Figure C.2 – Illustration of active laser guard parameters

A₂ Annex D
(normative)

Proprietary laser guard testing

D.1 General

This annex contains details of the test conditions to be adhered to and the documentation to be supplied by manufacturers of proprietary laser guards.

It should be noted that it is inappropriate to use higher power lasers to simulate low power laser parameters or use low powered lasers to simulate high powered, by changing irradiance or by adjustment of the distance from the focal point, because beam quality and other characteristics of the laser beam are likely to be different or unexpected. Manipulating characteristics of lasers of a certain power level to make or extrapolate estimates of a laser in a different level (higher or lower power) is not permitted.

The evidence of the tests described herein is relevant only for, and is limited to, the laser parameters used. Thus the results of these tests should serve only for comparison of laser guards.

The protective exposure limit (PEL $W \cdot m^{-2}$) shall be applicable only for the beam dimensions at the guard used in the tests. These dimensions at the guard shall be stated by the laser guard manufacturer because the PEL, which indicates protection, decreases as the laser beam dimensions increase. If the PEL is exceeded, the guard can be damaged and eventually disintegrates. For the purposes of this annex the protection time is the time interval from initial irradiation of the front surface until the laser radiation emitting beyond the rear surface exceeds the accessible emission limit (AEL) for Class 1 as defined in IEC 60825-1.

D.2 Test conditions

A variety of exposure limit tests with different materials and different lasers may cause non-reproducible results that can lead to false interpretations for the protective exposure limit and overestimated lifetime predictions of laser guards. Thus equal and comparable conditions for repeated tests must be ensured to maintain the integrity of the results.

As part of ensuring the integrity of the results, effort shall be made to eliminate or at least minimise systematic or other errors that may also result in false interpretations for the PEL or overestimation of the guard lifetime. Such errors may arise from:

- a) material: reflecting surfaces, where reflectivity changes through oxidation or contamination;
- b) laser: with high power lasers (e.g. multi-kilowatt lasers), especially those with good beam quality (i.e. fibre lasers and disk lasers), reactions have been seen that have considerable influence on the actual irradiance on the surface of the laser guards.

Thus during testing, it is important that no mechanical or physical effects (such as described below) occur between the beam aperture and the point of incidence on the guard material that adversely affect any optical properties. It is important to note that testing conditions should be accurately replicated, otherwise the resultant PEL or protection times may not be reliably reproduced.

Examples of effects that influence test results include but are not limited to:

- generation of fine metallic fume, whereby laser radiation is absorbed (e.g. thermal blooming) or scattered (e.g. Mie effect) in the metallic fume; **A₂**

- change of the focal point (thermal induced focal shift), whereby there is a change of the power density at the surface of the laser guard. These effects may reduce the laser power on the sample under test;
- establishment of an equilibrium (i.e. thermal equilibrium or balance between, incident and reflected or reemitted radiation) leading to a practically infinite PEL or protection time in one test, while a repeated test under assumed equal conditions leads to a finite PEL or protection time.

The tested exposure limit ($W \cdot m^{-2}$ for CW lasers or $J \cdot m^{-2}$ for pulsed lasers) shall be determined by tests performed when irradiating at least six samples by irradiating one surface of each sample. Each sample shall be of representative thickness and composition, having a front test surface prepared to give worst case absorption to laser radiation. Dimensions of these samples shall be not less than 3 times the beam diameter measured at the points where the intensity distribution has decreased to a value of $1/e^2$ of the peak at the exposure location (thereby guaranteeing that the radiant heat flow is taken into account). Structural connecting elements shall only be included in the tests if they are necessary to ensure the construction and integrity of the guard. In the case of non-circular beams, the geometry of the beam used in the test shall be specified. Non-circular beams are those where the difference between the major and the minor dimension is greater than 10 %. The tests shall be performed in both pulsed and CW mode where pulsed and CW laser operation is possible as the pulsed radiation may lead to different results.

NOTE 1 The parameters of pulsed radiation used in these tests should be representative of the parameters to be used in any specified application.

NOTE 2 The geometry of the test beam is required to be specified because it affects the distribution of heat in the sample.

NOTE 3 Particular care should be taken in the preparation of samples when testing laser guards using aluminium, copper, stainless steel and materials with zinc coated surfaces. It has been observed for these and other similar materials, the PEL and protection time is highly dependant on sample preparation and experimental setup that affects the repeatability of the PEL and protection time measurements.

NOTE 4 The worst case absorption should take into account the reflectivity of the guard material and the changes to the surface of the laser guard material over the foreseeable lifetime of the laser guard. However, the test plate should not have been treated beforehand, in any possible way that could alter absorption conditions artificially, except for accelerated natural reflectivity change of the guard material and the accelerated natural changes to the surface of the laser guard material reasonably expected over the foreseeable lifetime of the laser guard. Qualification test should be done in normal conditions for the laser shielding."

If a sample holder is necessary for the tests, then its maximum overlap on the sample edge shall not exceed 3 mm from the edge of the sample. The holding arrangement in contact with the sample shall be thermally insulating (e.g. ceramic, etc.) compatible with use at the temperatures generated.

The sample shall be normal (or tilted no more than $\pm 3^\circ$ to avoid retro-reflections) to the laser beam with the beam axis centred on the sample at a distance 'F1' as shown in Figure D.1. The distance F1 past the focal point shall be not greater than 3 times the focal length (F) of the focusing lens. If for a specific application the guard is to be positioned at a distance less than 3 times the focal length (F) away from the focal point, the minimum distance between the focal point and the guard has to be taken as the distance F1.

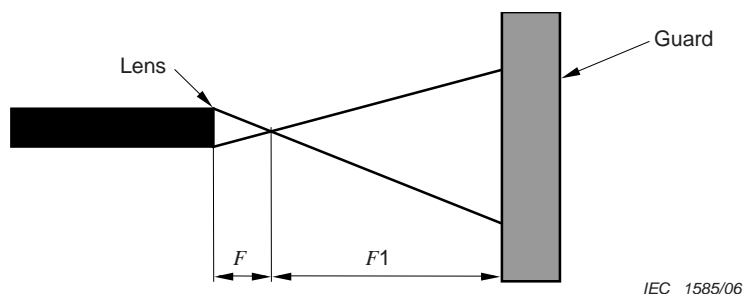
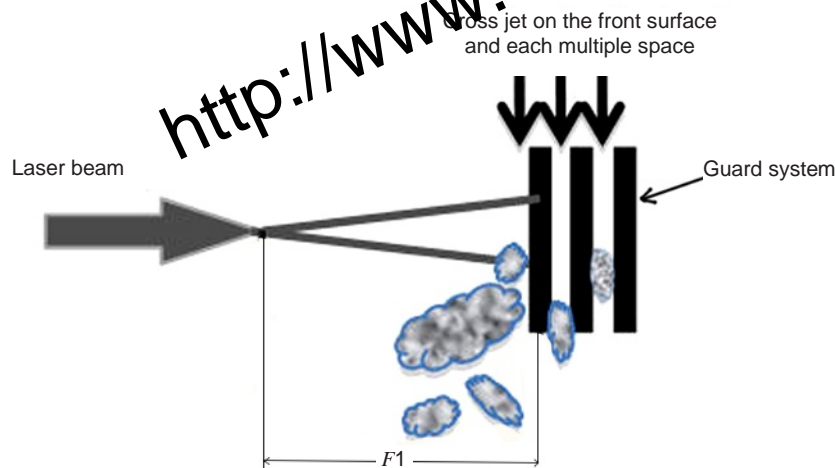

Figure D.1 – Simplified diagram of the test arrangement A2

A2 NOTE 5 Test should be performed with horizontally directed beam as shown in Figure D.1. If different beam direction were used, mention the test arrangement regarding the beam direction in the qualification report.

The surface of the sample under test shall be sufficiently ventilated (e.g. by using a cross jet) to ensure that the test surface and the space between the test sample and the beam shaping optics remain clear of debris, fume, etc. during the period of the test. The ventilation shall have the same effect as the air circulation in the intended application.

In addition, where there are multiple layers to the sample guard, all internal surfaces and internal spaces shall be sufficiently ventilated (e.g. by using a cross jet) to ensure that all surfaces remain clear of debris, fume etc. during the period of the test.



IEC 668/11

Figure D.2 – Simplified diagram of the ventilation for the guard under test

For passive guards: the accessible laser radiation at the rear surface of the sample shall not exceed Class 1 AEL during the test exposure, the duration of which is dependant on the period of exposure set by the manufacturer of the proprietary guard. The protection time of the guard must exceed the maintenance inspection interval as defined in Table D.1 subject to the intended laser guard usage.

Maintenance inspection intervals of proprietary laser guards should be specified by their manufacturer using test classifications T1, T2 or T3 as defined in Table D.1. Maintenance inspection intervals represent the time interval after which the guard is completely inspected and verified as not damaged or deteriorated. This is to ensure that the guard is in a state that can tolerate exposure to laser radiation for a further maintenance interval.

Table D.1 – Laser guard test classification

Test classification	Maintenance inspection intervals	Suggested laser guard usage
T1	30 000	For automated machine usage
T2	100	For short cycle operation and intermittent inspection
T3	10	For continuous inspection by observation

For active guards the following shall be required:

- a) If the active guard is a part of a safety-related control system of a machine, the relevant and appropriate standard for safety-related control systems shall be applied. **A2**

- A2**) b) The active laser guard shall output the laser termination signal, (which is intended to lead to automatic termination of the laser radiation) in response to any exposure of its front surface to laser radiation in excess of the specified exposure (level and duration). A reasonably foreseeable fault within the active guard system shall not lead to the loss of the safety function. A reasonably foreseeable fault within the guard element shall be detected at or before the next demand upon the safety function.
- c) The accessible laser radiation at the rear surface of a sample of the passive laser guard, incorporated in the active laser guard, shall not exceed Class 1 MPE in response to any exposure of its front surface to laser radiation up to and including the specified exposure for an exposure duration greater than the specified active guard protection time (as defined in Clause 3.1).
- d) If automatic functionality checks within the active guard system are made during periods of laser emission that temporarily interrupt the operation of the active laser guard system, the accumulated time taken to complete these checks shall take into account the effect of any repetitive laser pulses and shall not exceed the active guard protection time or cause any reduction in the overall performance of the active laser guard.
- e) The operation of an active guard is dependent on changes of physical parameters causing the initiation of the active guard termination signal. The active guard shall be continuously monitored during the period of potential laser exposure. At other periods, the active guard shall be unaffected by parameter changes (for example, smoke, humidity, vibration or shocks, temperature changes) and any other changes in the environment, thus preventing the active guard from being inadvertently disabled.
- f) Any damage to the active guard shall be detected at or before the next demand for protection and until that damage has been rectified, further operation shall be prevented.

D.3 Protective exposure limit (PEL)

The protective exposure limit (PEL) (as defined in 3.13) or protection time shall be determined from the results obtained from the measurements made. When calculating the protection time from the sampled data, the central limit theorem shall be applied presuming an underlying normal distribution. A confidence level of 99 % is required and is ensured by using $\pm 3\sigma$, where σ is the standard deviation in the normal distribution as given by

$$p(x) = \frac{1}{\sigma\sqrt{2\pi}} \exp\left(-\frac{(x-\mu)^2}{2\sigma^2}\right)$$

Where $p(x)$ = probability of x , x = individual value of a sample and μ = mean of the samples.

The quoted PEL shall be equal to $0,7 \times$ tested exposure limit.

The protection time shall be equal to $0,7 \times (\mu - 3\sigma)$.

NOTE The factor 0,7 referred to in the equation for PEL or protection time is introduced as an additional safety factor.

D.4 Information supplied by the manufacturer

The manufacturer shall provide with the set of test sample data at least the following information:

- a) name and address of the organisation conducting the tests;
- b) the number of this standard; **A2**

- A2** c) the material and its specification or internationally recognised standard to which it is made or rated, used for the samples. Details of any heat treatment, work hardening, surface finishes or other process applied to the material shall be included in this specification;
- d) the number of samples used in the tests;
- e) details of the laser parameters used including at least:
- i) the laser wavelength;
 - ii) the power or energy (specifying peak or average) at which testing was conducted;
 - iii) the pulse duration and repetition rate (for tests using a pulsed laser);
 - iv) the beam diameter at the input of the focal lens;
 - v) the beam quality expressed appropriately, for example, the beam parameter product or M^2 ;
 - vi) a measurement of the radiant exposure or irradiance of the beam at the surface under test;
- f) focal length of the focus lens used in the tests;
- g) the distance F1;
- h) the maintenance inspection interval applicable to the laser guard;
- i) the resultant PEL and/or protection time together with any calculations and statistical analyses made. **A2**
-

<http://www.china-gauges.com/>

Annex E
(informative)

**Guidelines on the arrangement and installation
of laser guards**

E.1 Overview

This informative annex addresses the arrangement and installation of guards to protect personnel against laser radiation hazards around the process zone of a laser materials processing machine. These guidelines are for use by manufacturers and/or users. The object of the annex is to encompass guarding for a stand-alone laser-processing machine (see ISO 11553-1 ²⁾) and additional (often user-installed) guarding required to safely integrate a laser-processing machine. Guarding issues relating to associated hazards of laser processing (which include mechanical, electrical, fume and secondary radiation hazards) are not considered in detail in this annex.

E.2 General

E.2.1 Introduction

Laser guarding is required to isolate the laser hazard in addition to the associated hazards of laser processing. Some of the guards may form part of a laser-processing machine, additional guarding may be used to facilitate safe loading and unloading of workpieces, and for servicing.

E.2.2 Arrangement of guards

Key elements in assessing the arrangement and installation of guards around the process zone include:

- a) the degree of accessibility required for workpiece handling (especially the degree of manual manipulation);
- b) the method of fixing the workpiece (e.g. use of jigs and clamps);
- c) the method of removal of the workpiece and any associated parts (e.g. scrap) after processing.

E.2.3 Location of guards

Good practice in determining the location of laser guards includes:

- the laser guard should be located at least 3 focal lengths away from the focal point of a focussing lens;
- laser guards with lower protective exposure limits (PELs), for example viewing windows, should not be located where the direct beam or specular reflections are expected.

²⁾ Also published by the European Committee for Standardization as EN 12626.

E.2.4 Complete enclosure

A complete enclosure is one which meets all the requirements for a protective housing as specified in 4.2.1 of IEC 60825-1 and encompasses the embedded laser and the entire process zone, such that there is no human access to hazardous radiation.

E.2.5 Incomplete enclosure

An incomplete enclosure is one which does not provide a complete protective housing encompassing the embedded laser and the entire process zone, such that human access to hazardous radiation is possible.

If the risk of exposure is not tolerable, (to those who may be on walkways or platforms which raise them above the guards of an open topped machine) additional control measures are required.

E.2.6 Hierarchy of control of laser hazard areas

The following hierarchy of measures is recommended for keeping persons out of an area where there is an intolerable risk:

- a) fit a fixed guard;
- b) fit a removable guard;
- c) fit an electronic protection device linked to the safety interlock chain of the machine, around the perimeter of the area (e.g. a light beam sensor) or over the area (e.g. a pressure mat);
- d) provide a physical barrier plus information, instruction, training, supervision;
- e) provide a means of allowing use with the operator some distance from the process zone plus personal protective equipment (PPE).

NOTE Measures (c) and (d) provide no protection from laser radiation emerging from the laser machine and should therefore only be considered where the distance of the controlled boundary from openings in the machine exceeds the "Nominal Ocular Hazard Distance" (NOHD).

E.2.7 Personal protective equipment

Personal protective equipment should only be used as a last resort where a combination of engineering and administrative controls cannot reasonably provide a sufficient level of protection. Where personal protective equipment is employed it should be supported with an adequate level of administrative control governing its use. It should only be used when a risk assessment has shown that the use of other means of risk reduction has failed to produce a sufficient degree of safety and when it is not reasonably practicable to ensure adequate protection by other means. When working with UVB and UVC, protective clothing may be required.

E.2.8 Human intervention

Where machine operations require human access, then human intervention can be included in the risk assessment and the consideration of implications for the duration of the fault condition. Under these conditions access should be controlled and accessible only to authorised persons who have received adequate training in laser safety and servicing of the laser system involved. The area should also be restricted and not open to the public and where observers or other untrained personnel are kept from being exposed to the hazards by barriers or administrative controls.

E.3 Risk assessment

E.3.1 Introduction

Human exposure to a laser beam of the type typically used in laser materials processing can produce a moderate to severe injury, depending on laser wavelength, tissue exposed and the response of the victim. The probability of such an exposure occurring becomes the key variable element in assessing the risk of injury. The reduction of risk to tolerable levels is an iterative process. There is no standard approach to procedure and documentation for this process. Nevertheless, the steps involved are universal and are described in ISO 14121.

E.3.2 General considerations

A risk assessment should be performed to identify hazardous situations and to assess the foreseeable exposure level at intended positions of a laser guard. This assessment should take into account a number of factors, including the following.

E.3.2.1 Features of the laser process zone

Relevant features include the laser power and wavelength, the focal length of optics, the degrees of freedom of the beam delivery (e.g. number of axes of movement).

E.3.2.2 Process

The nature of the process, such as cutting, drilling, welding, marking. The machine may be dedicated or offer several processes.

NOTE Reflected laser powers differ appreciably with process and material being processed.

E.3.2.3 Process control

This factor addresses in particular the time during which laser guards may be exposed under fault conditions, including those upon which the foreseeable exposure limit (FEL) is determined (e.g. the process cycle time), the inspection process (e.g. per item or per time period/ number of items), and the means and effectiveness of automatic process control intervention in the event of a fault condition becoming evident.

E.3.2.4 Manual operations

Operator intervention considerations include the need and provision for manual control, the means and effectiveness of process observation (including the location of viewing windows or cameras) and the accessibility and effectiveness of intervention in the event of a fault condition becoming evident.

E.3.2.5 Robot operations

The full range of robot movements, impact protection for the robot head and general protection of service lines and the beam delivery to the robot, and the means of limiting robot head movement and direction (e.g. software limits, hardware limits and physical limits), in particular the closest approach of the exposed laser beam to laser guards.

E.3.2.6 Workpiece

The geometry, composition and surface finish of the workpiece, and how it can affect the direction and strength of reflections during laser processing.

E.3.2.7 Clamping and fixturing

The holding and positioning of the workpiece and the related issues of reflections from surfaces and collisions of the focussing head.

E.3.2.8 Loading and unloading

The method by which the workpiece is introduced and removed, in particular whether it is manual or automatic, single piece or continuous, and the method (e.g. sliding, rolling or lifting door) and control of access to the process zone.

E.3.2.9 Beam delivery

Beam delivery considerations include the optical method (mirror or fibre) and means of inspection, positioning and movement of optical components. Considerations include the structural integrity of the mounting of beam path components, means of maintaining the condition of optical components (e.g. clean dry gas purge plus cooling supply), means of maintenance of beam alignment, provision of on-line errant and non-errant beam monitoring, and means of construction of the beam delivery enclosure.

NOTE Particular attention should be given to the use of novel (unproven) design of laser beam delivery, the exposure of the beam delivery structure to external mechanical forces (e.g. vibration) which may give rise to optical misalignment. Attention should also be given to tampering with optics or anomalous performance of lasers, especially in regard to beam pointing, and situations where the laser power is so high that the performance of beam delivery optics is uncertain.

E.3.2.10 Location of workers

The defined work area, in particular the minimum distance of permitted approach to the machine. Included in this consideration are overhead locations (e.g. crane operators, office workers on elevated walkways), steps and ladders in the vicinity.

E.3.2.11 Maintenance provision

This consideration includes the means and control of access to maintenance positions (e.g. removable panels, key control) and the provision of interlock overrides and emergency stops.

E.3.2.12 Guarding properties

The assessment of FEL and PEL under normal conditions and reasonably foreseeable fault conditions should be made for each element of guarding, including fixed and moveable walls and windows.

E.3.2.13 Guarding environment

Environmental factors that may influence the effectiveness of the guarding, including access for fork lift trucks and other moving objects that could cause significant mechanical damage, and dusty environments that could adversely affect the performance of optics and/or the protective properties of the guard.

E.4 Examples of risk assessment

E.4.1 Continuous feed of components

- Example

Laser processing unit mounted over a conveyor belt.

- Location

During normal production or maintenance, access is controlled and only accessible to authorised persons, but the area may also be unrestricted and open to observers or other untrained personnel.

During service periods, the area may also be restricted and not open to other untrained personnel.

- Key issue

The arrangement of laser guarding should include entry and exit ports to permit the feeding of components into and out of the process zone on a continuous basis.

- Possible solutions

Where the risks of excessive laser radiation are high:

- provide interlocked sliding guard, which opens to permit entry of the component, and closes prior to laser processing.

Where the risks of excessive laser radiation are medium or low (possible solutions following the risk assessment):

- provide local guarding with a brush seal to maintain enclosure during passage of component, or
- provide an open tunnel around opening(s) to restrict line-of-sight access to the laser process zone. This may be accomplished by:
 - using a labyrinth for the component entry and exit paths in order to block direct line of sight, or
 - by the use of an interlocked barrier (e.g. light guard or fencing) or a pressure mat that is approved for safety applications, to restrict the viewing position in order to prevent a direct line of sight.

E.4.2 Flatbed laser cutting and marking

- Example

Flatbed cutting table in laser job-shop environment.

- Location

During normal production or maintenance and service periods, access is controlled and only accessible to authorised persons and restricted to trained personnel only.

- Key issues

Access to the table is required for loading and unloading of sheets onto the cutting table.

- Possible solutions

Where the risks of excessive laser radiation are high (for example where hazardous laser radiation is generated from reflections which are present during normal production):

- provide full perimeter guarding to protect the operator and other personnel. Interlocked sliding guard opens to permit passage of component and closes prior to laser processing.

Where the risks of excessive laser radiation are medium or low (for example beam is directed vertically onto a flat workpiece and enclosed to within a short distance of the workpiece):

- provide free-standing guard to protect the laser operator;
- provide PPE requirement for all persons within the restricted access zone.

In all cases, provide adequate controls to ensure unauthorised and untrained persons are prevented from exposure to any hazard that may cause harm.

E.4.3 Multi-axis processing machine

- Example

Automated robotic laser welder on an automobile line.

- Location

During normal production or maintenance, access is uncontrolled and the area is unrestricted and open to observers or other untrained personnel.

During service periods, access would be controlled and only accessible to authorised persons and the area restricted and not open to other untrained personnel.

- Key issue

A fault condition in the controller could lead to the laser beam being directed at the laser guarding.

- Possible solutions

Where the risks of excessive laser radiation are high:

- provide reinforced guarding at parts of process zone enclosure indicated as vulnerable by the risk assessment. This reinforcement may be by using an active guard.

Where the risks of excessive laser radiation are medium or low:

- the elements of solution may include:
 - provide guarding which has a verified performance being tested as described in IEC 60825-4 for direct exposure to representative laser beam;
 - provide software control and hardwire limits to beam-line rotational movement;
 - provide collision protection of the beam-line 'head';
 - provide additional sensors for preventing laser emission beyond the workpiece;
 - provide control of the laser emission if the laser focusing head is stationary.

E.4.4 Laser guards for supervised areas

- Example

Temporary laser guards set up during service activities to exclude persons not involved in the servicing operation.

- Location

During normal production or maintenance, these laser guards could not be used as a protective guard.

During service periods, access would be controlled. The location is only accessible to authorised persons who are trained in laser safety. The location is not open to other untrained personnel as indicated by administrative means (e.g. warning signs).

- Key issue

Beam direction is under administrative control.

- Possible solutions

Where the risks of excessive laser radiation are high, the elements of solution include:

- ensure laser guards are opaque and are capable of at least 100 s protection from the laser beam;
- entry to the screened off area interlocked or under direct administrative control;
- use trained personnel to carry out such service operations;
- protective laser eye wear (and possibly skin wear) to be used by all those inside the controlled area.

Where the risks of excessive laser radiation are medium or low (e.g. area outside the laser guard is cleared of personnel):

- as above, except that the protection time provided by the screen may be less than 100 s provided the service engineer has ready access to the laser shutter control and laser exposure of the screen provides a clearly visible indication (e.g. smoke or strong discoloration).

E.5 Aids to risk assessment

This clause provides a list of items to be considered when assessing the risks associated with a laser-processing machine in the design of laser guards. These details should form part of a documented record of the assessment.

Note that this list is NOT comprehensive and may not include all the aspects that should be considered.

E.5.1 Equipment

- Laser
 - Type
 - Wavelength
 - CW/pulse
 - Pulse duration

- Pulse repetition rate
- Power (or energy)
- Beam delivery output lens focal length
- Processing machine type
 - 2-axis machine
 - 3-axis machine
 - machine with more than 3 axis
 - robot
 - fume extraction fitted
 - process zone enclosure:
 - Class 1 AEL
 - other

<http://www.china-gauges.com/>

E.5.2 Process machine beam delivery

- Beam delivery path monitoring:
 - by hardware control
 - by software control
- Beam delivery turning mirror monitoring:
 - by hardware control
 - by software control
- Beam delivery mechanical assembly:
 - requires use of tools
 - monitoring provided
 - by hardware control
 - by software control
 - beam focus lens control assembly
- Free space beam delivery system
- Fibre optical beam delivery system

E.5.3 Process description

- Soldering/brazing
- Heat treatment
- Marking
- Welding
- Drilling/cutting
- Cleaning
- Forming
- Rapid prototyping

E.5.4 Process machine controls

- For automatic mode operation (i.e. no operator intervention):
 - fully guarded operation

- For manual mode operation (i.e. where manual intervention during the machine cycle is intended):
 - fully guarded operation
- Method of process observation:
 - use of windows in the process zone enclosure
 - use of CCTV monitoring
 - other
- Method intended to stop the cycle if an error observed:
 - Emergency Stop
 - Normal Stop

E.5.5 Basic description of robot (see ISO 10218)

- Swing range:
 - restricted space
 - maximum space
 - safeguarded space
- Method of limiting range of motion:
 - hardware control
 - software control
- Method of safeguarded space interlocking:
 - hardware control
 - software control
- Collision sensing:
 - hardware control
 - software control
- End position control:
 - hardware control
 - software control

E.5.6 Types of processed parts

- Type of geometry
 - plate
 - other
- Type of material

E.5.7 Part fixture

- Automatic location and clamping:
 - by hardware control
 - by software control
- Manual location and clamping
- Laser beam damage potential
 - due to reflective areas on the tooling
 - due to surface finish of the tooling

E.5.8 Material flow into the process zone

- Automated continuous flow of components
- Manual single component
- Process zone component access:
 - sliding door
 - lift door
 - rolling door
 - tunnel
 - other
- Component feed control:
 - by hardware control
 - by software control
 - process zone guarding designed to IEC 60825-4 requirements
 - process zone enclosure tested to IEC 60825-4 requirements

E.5.9 Process machine operator

- Working area
- Inside machine
- Outside machine

E.5.10 Maintenance

- Position of maintenance access doors
- Method of machine authorisation (key controls)
- Hold-to-run controls

<http://www.china-gauges.com/>

Annex F (informative)

Guideline for assessing the suitability of laser guards

F.1 Identification of hazards

F.1.1 Selection of safety measures

When applying the strategy for selection, it may not be possible to use the more effective types of safety measures because they are either not technically feasible or are not suitable for their particular application.

In considering measures for all the hazards during each relevant phase of machine life, risk assessment techniques will assist in choosing the best possible combination of safety measures.

The phases of machine life to be considered are:

- installation;
- commission;
- operation;
- setting or process changing;
- cleaning;
- adjustment;
- maintenance.
- service

There may be conflicting requirements and priority should be given to those phases which give rise to the greatest risk. For example, the maintenance, setting and adjustment phases may require to be given greater emphasis. The aim is to minimise total risk.

F.2 Risk assessment and integrity

F.2.1 General

As with other machinery, all mechanical hazards should be identified. These hazards include:

- entanglement;
- friction and abrasion;
- cutting;
- shear;
- stabbing and puncture;
- impact;
- crushing;
- drawing in;
- injury by compressed gas or a high pressure fluid system.

Non-mechanical hazards may also be present. These hazards include:

- access:
 - slips, trips and falls;
 - falling objects and projections;
 - obstructions and projections;
- handling and lifting;
- electricity (including static electricity):
 - shock;
 - burns;
- chemicals that are:
 - toxic;
 - irritant;
 - flammable;
 - corrosive;
 - explosive;
- fire and explosion;
- noise and vibration;
- pressure and vacuum;
- temperatures (high and low);
- inhalation of mist, fume and dust;
- suffocation;
- ionising and non-ionising radiation;
- biological e.g. viral or bacterial.

<http://www.china-gauges.com/>

Many of the safeguards, which are adopted in order to eliminate personal harm from non-mechanical hazards, will need to be considered in conjunction with the safeguarding against the mechanical hazards identified in order to minimise the total risk level.

F.2.2 Guard reliability

The greater the risk, the greater is the need to protect against it. The reliability of the safety measure should increase as the probability or severity of injury resulting from failure of the measure increases. This applies to safeguards and controls in general, to interlocks and to guard materials.

The identification of the various hazards should be followed by a careful study of the possible failures or combinations of failures, which might lead to these hazards causing injury. In any system where a failure may adversely affect safety, each component within the system should be considered in turn. The likely types of failure and their consequences for the system as a whole should be taken into account. A formal method of analysis, such as Failure Modes and Effects Criticality Analysis (FMECA) should be used when higher risks are involved. It is also necessary to consider the reliability of operating procedures when safety depends upon them. This should include both inadvertent and deliberate failure to follow procedures.

Guards should achieve their safety function with minimal downtime and the least reduction in productivity. It should be recognised that production pressures or well intended zeal could lead to safeguards being defeated. Designers should design and construct safeguards to make bypassing or defeating them, whether deliberately or by accident, as difficult as is reasonably possible.

This annex only considers the features of guards that directly relate to giving protection from excessive exposure to laser radiation.

A number of special hazards should be considered associated with:

- the type of machine;
- the wavelength(s) of laser radiation;
- number of axes of movement of the machine;
- complexity of beam path.

F.2.3 Practical risk assessment methods

F.2.3.1 Generalised risk assessment methods

These methods are outlined in Annex E.

F.2.3.2 Risk assessment as suggested in ISO 13849-1

ISO 13849-1 deals with those parts of machinery control systems assigned to provide safety functions. These parts can consist of hardware or software and they provide the safety functions of the control system. They can be separate or integrated parts of the control system. The performance of a safety related part of a control system, with respect to the occurrence of faults is allocated in this standard into five categories (B, 1, 2, 3, 4) which should be used as reference points.

The category selected, as defined in ISO 13849-1, will depend upon the machine and the extent to which control means are used for the protective measures.

When selecting a category and designing a safety-related part of a control system the designer will need to declare at least the following information about the safety-related part:

- the category(ies) selected;
- the functional characteristics;
- the precise role the safety-related control plays in the machinery protective measure(s);
- the exact limits of the safety-related control;
- all safety-relevant faults considered;
- those safety-relevant faults not considered by fault exclusion and the measures employed to allow their exclusion;
- the parameters relevant to the reliability, such as environmental conditions
- the technology(ies) used.

The use of the categories as reference points and the declaration of rationale followed during the design process is intended to allow this standard to be used with flexibility. The standard provides a clear basis upon which the design and performance of any application of the safety-related part of the control system (and the machine) can be assessed.

The main body of the standard describes the process for selection and design of the safety measures together with the characteristics of the safety functions and the fault considerations.

Annex B of ISO 13849-1 is particularly useful in providing guidance of the selection of categories including a method for risk estimation.

F.2.3.3 ALARP

This method is intended to reduce risks to “as low as reasonably practicable” (ALARP) by means of a structured approach to design and implementation. The main tool is to use good practice. In this context, good practice is the generic term for those procedures for controlling risk. Written good practice may take many forms. The scope and detail of good practice will reflect the nature of the hazards and risks, the complexity of the activity or process and the nature of the relevant legal requirements. Examples of written sources, which may be recognised, include guidance produced by government departments, standards produced by standards-making organisations (e.g. CEN, CENELEC, ISO, IEC) and guidance agreed by a body (e.g. trade federation, professional institution) representing an industrial/occupational sector.

Table F.1 shows how ALARP could be applied.

Table F.1 – Application of ALARP

Project stage	Elements in demonstrating that risks are as low as is reasonably practicable
Choosing between options or concepts	Risk assessment and management according to good design principles. Demonstrating that duty-holder's design safety principles meet legal requirements. Demonstrating that chosen option is the lowest risk or justification, if not the lowest risk. Comparison of option with best practice, and confirmation that residual risks are no greater than the best of existing installations for comparable functions. Risk considered over life of facility and all affected groups considered. Societal concerns met, if required to consider.
Detailed design	Risk assessment and management according to good design principles. Risk considered over life of facility and all affected groups considered. Use of appropriate standards, codes, good practice etc. and any deviations justified. Identification of practicable risk reduction measures and their implementation unless demonstrated not reasonably practicable.

F.3 General design

Designers of new machinery, where considering safety, should follow the general principles laid down in ISO 12100-1 and ISO 12100-2, also taking into account any other specialised standards that relate to the particular machine. As a practical guide whenever practicable, hazard zones should be eliminated or effectively enclosed. If they cannot be eliminated, then suitable safeguarding should be incorporated as part of the design or made easy to incorporate at a later stage.

At the design stage, arrangements should be made, where practicable, to eliminate the need to expose any hazard zones during operation, examination, adjustment and maintenance.

Designers should take into account the ergonomics of the machinery use, i.e. they should consider all aspects of the work situation for which the machine was intended. The objective is to provide for laser safety while giving the optimum performance of the machine and operator.

Among the aspects to consider is the creation of a favourable environment for the operator and others in the vicinity nearby, providing heating, cooling, lighting and, where necessary, mechanical aids to reduce physical effort and controlling to an acceptable level the emission of heat, light, laser radiation, noise, dust, fumes and liquids.

The designer should be aware of the hazards identified above, and as many of these hazards as possible should have been avoided by suitable choice of design features. Where it is not possible to avoid these hazards, the designer should have examined the factors, which influence the magnitude of the risk and may influence the severity of the injury. Factors which may influence the frequency of exposure and hence the probability of injury should also have been considered.

Controls should be positioned so as to provide safe and easy operation, and there should be ample clearance between each control and other parts of the machinery. Methods discussed in IEC 60204-1 and IEC 61310-3 should be adopted.

For laser guards particular consideration should be given to:

- difficult situations where gaps are necessary;
- flaps, skirts and brush seals;
- open top enclosures;
- jointing between panel sections and window fixings;
- improving access (e.g. up and over doors, curtains);
- the atmosphere inside enclosures: safe to enter (fume and excess or depletion of oxygen);
- viewing windows in enclosures;
- secondary (sacrificial) screens;
- geometrical and general layout considerations;
- design issues relating to type (wavelength) of laser, type of beam manipulation, beam delivery etc.

F.4 Selection of safeguards

Where access to the danger zone is not required during normal operation of the laser-processing machine, safeguards may be selected for the following:

- fixed enclosing guards;
- fixed distance guards;
- movable guards.

Where persons require access to the danger zone, e.g. for setting, process correction, maintenance or servicing, operational safeguarding may not be fully effective. In these circumstances, safe-working practices such as isolation should be used, augmented where necessary with additional safeguards. The use of such practices will require planning and discipline by all concerned.

Where access to the danger zone is required for normal operation, safeguards may be selected from the following:

- interlocking guards;
- adjustable guards;
- temporary guards.

F.5 Guard design and construction

F.5.1 General requirements for the design and construction of fixed and movable guards

In designing the safeguarding system, the types of guard and the methods of construction should be selected to take into account the mechanical and other hazards involved, in addition to the laser radiation hazard. They should provide the minimum of interference with activities during the operation and other phases of the machine life, in order to reduce any incentive to defeat the safeguard.

Guards should preferably be designed to follow the contours of the machine. Where this is not possible, e.g. for maintenance or because of machine geometry, measures should be taken to reduce the need for presence within the danger zone. Additional safety measures may be required to protect personnel working within the danger zone. These may be provided by safeguards and/or safe working practices.

F.5.2 Fixed enclosing guards

A fixed guard is a guard which is kept closed and in place. Not only should the guard prevent access to hazard zones or laser radiation, it should be of robust construction, sufficient to withstand the stresses of the process and environmental conditions.

If the guard is capable of being opened or removed, this should only be possible with the aid of a tool. Preferably the fastenings should be of the captive type.

When it is necessary for work to be fed through the guard, openings should be sufficient only to allow the passage of material but should not allow the material to get trapped. The guard in these situations should also prevent access to laser radiation, meeting the requirements for the prevention of human access given in IEC 60825-1.

F.5.3 Fixed distance guards

A fixed distance guard is a fixed guard which does not completely enclose the hazard but which reduces access by virtue of its physical dimensions and its distance from the hazard. An example of a distance guard is the perimeter fence surrounding a machine. This type of guard requires extreme care in design if human access to excessive laser radiation is to be prevented. The surrounding guard of an open topped laser processing machine may be considered a fixed distance guard if it is sufficiently high so as to prevent human access to the laser radiation.

F.5.4 Movable and interlocking guards

An interlocking guard is a guard, which is movable or has a movable part, whose movement is interconnected with the power or control of the machine.

An interlocking guard should be so connected to the machine control that

- a) until the guard is closed the interlock prevents the generation of hazardous laser radiation by interrupting its power source or closing a beam shutter;
- b) either the guard remains locked and closed until the risk of injury from the hazard has passed or opening the guard causes the hazard to be eliminated before access is possible.

Interlocking rise and fall screens, which are capable of inflicting injury in the event of their falling under gravity, should be provided with a suitable anti-fall device. Some interlocking guards may be power driven and, in such cases, adequate steps should be taken to avoid injury due to the movement of the guard.

The interlocking system may be mechanical, electrical, hydraulic or pneumatic or any combination of these. The type and mode of operation of the interlock itself should be considered in relation to the process to which it is applied. The interlocking system should be designed to minimize the risk of failure to danger and should not be easily defeated.

F.5.5 Adjustable guards

An adjustable guard is a fixed or movable guard, which is adjusted as a whole or which incorporates an adjustable part or parts. The adjustment remains fixed during a particular operation. It is essential that a suitably trained person carefully carries out the adjustment. Regular maintenance of the fixing arrangement is necessary to ensure that the adjustable element of the guard remains firmly in place once positioned. The guard should be so designed that the adjustable parts cannot easily become detached and mislaid.

F.5.6 Temporary guards

Temporary guards are those that may be positioned during maintenance or service and may be appropriate to supplement overall protection from the laser radiation hazard during the period that permanent guards normally mounted on the processing machine are displaced or removed. Adequate warning signs should be placed on or adjacent to the temporary guards to augment any additional administrative protection measures to ensure the effectiveness of the temporary guards. Procedures should be put in place to ensure that the displaced or removed permanent guards are replaced and the temporary guards removed before the processing machine is returned to normal operation.

F.6 Guard construction and materials

Any guard selected should not itself present a hazard such as trapping or shear points, rough or sharp edges or other hazards likely to cause injury.

Guard mounts should be compatible with the strength and duty of the guard.

Power operated guards should be designed and constructed so that a hazard is not created.

ISO 14120, gives general requirements for the construction of fixed and movable guards and should be considered in addition to this standard.

F.6.1 Materials

F.6.1.1 General

In selecting the material to be used for the construction of a guard, consideration should be given to the following:

- a) its ability to withstand the forces of any foreseeable hazard associated with the laser processing machine. The guard may fulfil a combination of functions such as the prevention of access and containment of hazards. These hazards include laser radiation, ejected particles, dust, fumes, noise, etc. One or more of these considerations may govern the selection of guard materials;
- b) its weight and size in relation to the need to remove and replace it for routine maintenance;
- c) its compatibility with the material being processed. This is particularly important in the food processing or pharmaceutical industry where the guard material should not cause a source of contamination;
- d) its ability to maintain its physical and mechanical properties after coming into contact with potential contaminants generated or used during processing operations or cleaning or sterilising substances used during maintenance.

F.6.1.2 Solid sheet metal

Metal has the advantage of strength and rigidity and in solid sheet form is particularly suitable for guarding where adjustments are rarely needed and there is no advantage in being able to see the working operation within the process zone. However, care should be taken to ensure that, where necessary:

- sufficient ventilation is provided for the guard to prevent overheating within the process zone, and
- the guard does not create a noise or vibration resonance.

Data is shown in Figures F.1 to F.22 that will aid the selection of suitable materials that withstand the foreseeable worst case laser radiation exposures.

F.6.1.3 Glass

Glass is unsuitable for guard manufacture due to its tendency to rupture but where a laser process is required to be observed and the material is likely to be exposed to high temperatures or abrasive action, a safety glass, which provides adequate protection from laser radiation (by internal absorption of the laser radiation within the material or suitable reflective optical coatings on the surface of the guard material) may be suitable. Methods for determining the suitability of such materials is given elsewhere in this standard.

F.6.1.4 Plastics

Transparent plastic sheet materials may be used in laser guarding as an alternative to opaque materials especially where observation is required during the processing operation.

Plastic materials available for guarding purposes include polycarbonate and specially dyed acrylic sheet. It is essential that these materials are selected with appropriate optical protective properties for the wavelength and power of the laser source fitted to the laser processing machine.

The mechanical properties of many plastics are adversely affected by contaminants, by incorrect cold working and by continuous exposure to high temperatures or UV radiation. Continuous exposure to high temperature (polycarbonate: 135°C, acrylic sheet: 90°C) will cause softening and consequently lowering of both impact strength and other optical properties.

Any removal of the surface material may reduce the optical protective properties of the material at laser wavelengths and the provision of additional sacrificial mechanical protective layers should be considered.

Most plastics have an ability to hold an electrostatic charge. This can create a risk of electrostatic ignition of flammable materials and can also attract dust. This characteristic can be mitigated by the use of an anti-static preparation.

F.6.1.5 Other materials

Concrete block work may be an effective material for some guard construction and is frequently used for large CO₂ laser processing machine enclosures

F.6.2 Supports

Guards may be fastened to independent supports or to the machinery itself. The number and spacing of the fixings should be adequate to ensure stability and rigidity of the guard.

Where necessary, there should be clearances around the guard for cleaning and debris removal etc., provided that this clearance does not allow access to the hazard zones.

F.6.3 Cover plates

Removable panels or cover plates may be incorporated into guards to provide easy access or improved visibility. They should be treated as part of the guarding system and may be considered as either fixed or interlocking guards depending upon the process requirements.

F.6.4 Anthropometrical considerations

Guards should be designed and constructed with the object of preventing any part of the body from reaching the danger zone. They should take into account the physical characteristics of the people involved and in particular their ability to reach through openings and over or around barriers used as guards. The best approximation of currently available data for human body measurements (anthropometrical data) are given in standard ISO 15532-3.

F.7 Other safety devices

F.7.1 Trip devices

A trip device is a device which causes working machinery to stop, or assume an otherwise safe condition, to prevent injury when a person approaches the danger zone beyond a safe limit. The device will be required to keep the machine in this condition while the person remains within the danger zone unless other means of fulfilling this function are provided.

A trip device should be designed to ensure that an approach to a hazard or danger zone beyond a safe limit causes the device to operate and the hazard to be terminated before injury can be inflicted.

A trip device should be designed so that after it has been operated it may be reset automatically or manually; restarting should then be by means of the normal start actuator. The trip device operation should not be impaired by any extraneous influences.

F.7.2 Electro-sensitive protection equipment

Electro-sensitive protective equipment is sometimes referred to as intangible barriers and operate as trip devices on the principle of detecting the approach of persons or parts of persons into danger zones etc. The means of detection can be active opto-electronic, active opto-electronic responsive to diffuse reflection, passive infra-red, capacitance, inductive, microwave, or visual intrusion. The effectiveness of the complete installation will depend not only on the integrity of the electro-sensitive protective equipment, but also on the electrical and mechanical integrity of the remaining installation, and the location of the electro-sensitive protective equipment sensing device relative to the danger zone.

F.7.3 Control systems (keys, pressure mats, light curtains)

F.7.3.1 Captive-key systems

Generally a captive-key interlocking device is a combination of an electrical switch with a mechanical key operated lock secured to the fixed part of the machine. The operating key is held captive on the moveable part of the guard. To open the guard, the key is turned, which puts the switch into the “off” position and releases the key from the lock so that the guard can be opened.

Some captive-key systems are made up of trapped-key interlocking systems. In a trapped-key interlocking system the guard lock and a switch that incorporates a lock, are separate as opposed to being combined into a single unit. The essential feature of the system is that the removable key is trapped either in the guard lock, or in the switch lock. The lock of the guard is arranged so that the key can be released only when the guard has been closed and locked. This allows transfer of the key from the guard to the switch lock. Closing the switch traps the key so that it cannot be removed when the switch is in the “on” position.

F.7.3.2 Pressure sensitive mats

Pressure sensitive mats and floors contain sensors that operate when a person or object applies pressure to the mat or floor. They should be subject to periodic maintenance and inspection, since by their nature, pressure sensitive mats are exposed to potential damage that can result in failure.

The dimension of mats should take into account a person's speed of approach, length of stride and the overall response time of the protective device. Care should be taken that access cannot be gained without actuation of the mat or floor. Account should be taken of dead surfaces within the mat especially around their edges, when a number of mats are used together. Guidance on the application of pressure sensitive mats may be found in IEC 62046. A pressure sensitive mat may be appropriate to indicate the presence of a person inside the machinery and/or stop the machinery if required.

F.7.3.3 Light curtains

Light curtains often operate on the principle of the detection of an obstruction in the path taken by a beam or beams of light. The intangible barrier operated by this system may consist of a single light beam device or a number of light beam devices arranged as a curtain. The curtain also may be created by a scanning light beam or a number of fixed beams. The light may be visible or invisible. The requirements for the design and performance of these devices for protective purposes are specified in IEC 61496-2.

F.8 Interlocking considerations

F.8.1 Functions of interlocks

An interlock provides the connection between a guard and the control system of the laser processing machine to which the guard is fitted. The interlock and the guard with which it operates should be designed, installed and adjusted so that:

- a) until the guard is closed the interlock prevents laser emission by interrupting the laser beam either by means of a beam attenuator or by removal of power from the laser;
- b) either the guard remains locked closed until the risk of injury from the hazard has been removed, or opening the guard causes the hazard to be eliminated before access is possible.

Care should be taken to ensure that actuation of an interlock installed to protect against one hazard does not create a different hazard.

F.8.2 Interlocking media

The four media most commonly encountered in interlocking are electrical, mechanical, hydraulic and pneumatic. Electrical interlocking, particularly in control systems, is the most common. The principles of interlocking apply equally to all media. Each has advantages and disadvantages, and the choice of interlocking medium will depend on the type of laser processing machine and the method of access to hazard zones.

Some interlocking systems have more than one control channel, e.g. dual control systems. It is often advantageous to design these systems so that single failures in both channels from the same cause (common cause failures) are minimised.

F.8.3 Common interlocking methods

F.8.3.1 Guard locking power interlocking

With guard locking power interlocking, the power medium is interrupted directly by a single device which is arranged so that:

- a) the device physically prevents the guard from being opened while the power medium is uninterrupted;
- b) the device is physically held by the guard in the position which is interrupting the power medium when the guard is open.

F.8.3.2 Interlocking guard power interlocking

With interlocking guard power interlocking, the power medium is interrupted directly by a single device that is automatically operated by movement of the guard. The guard and device should have been arranged so that the power medium is interrupted as the guard is opened, and remains interrupted while the guard is in any position other than closed.

F.8.3.3 Dual-control system interlocking with cross monitoring

In dual-control system interlocking with cross-monitoring, there are two separate power interrupting devices, each capable of interrupting the power medium. The devices should be arranged in series, so that the operation of either will result in the interruption of the power medium. These are operated by individual devices actuated by the guard.

The power interrupting devices should have been monitored so that the failure of either their control systems or the interrupting devices themselves, to respond to the control system signal will be immediately detected and a further operating cycle of the laser processing machine prevented. The circuitry of each power interrupting device, including its operating device, should be kept physically separated as far as is practicable, to reduce the probability of the interlocking system failing to danger as a result of common cause failures.

F.8.3.4 Dual-control system interlocking without cross monitoring

Dual-control system interlocking without cross-monitoring follows the same principles as those described above but without the facility to monitor automatically the correct functioning of the two power interrupting devices.

In the absence of automatic monitoring, it is possible for either interlocking channel to fail to danger and for the fault to remain undetected, which then reduces the integrity of the system to that of single-control system interlocking. For dual-control system interlocking without cross-monitoring to function effectively, however, it is important that a regular check is carried out to ensure that both channels are working correctly. The frequency of checking will depend on the reliability of the components used and the conditions under which the interlocking system is operating.

F.8.3.5 Single channel system interlocking

Single-control system interlocking employs an interlocking device which indirectly interrupts the power medium by operating a single power interrupting device via a control system. It does not have a high level of integrity because of the greater possibility of single component failure in the system causing the whole system to fail to danger. The system, therefore, should have been designed and installed using the minimum number of components.

The system should be inspected and tested regularly and any worn or damaged components replaced or repaired.

F.8.4 Failures of interlocking systems

Interlocking systems should be designed to minimise the possibility of the interlocking system as a whole to fail to danger.

As power supplies frequently fail, components relying on the power supply for their functioning should be installed so that power loss minimises failure to danger of the system as a whole.

F.8.4.1 Types of failure

The most common types of failure from which an interlocking system may suffer are:

- a) failure, interruption or variation of externally supplied power;
- b) open circuits in electrical systems;
- c) mechanical failure, e.g. breakage or seizure;
- d) malfunction due to electrical environment, i.e. mains borne or radiated disturbance;
- e) malfunction due to vibration;
- f) malfunction due to power supply contamination;
- g) earth faults, i.e. accidental connection of a conductor to earth causing, for example, unexpected start-up or failure to stop;
- h) other single component failures leading to change of characteristic or loss of function;
- i) cross-connection failures causing, for example, unexpected start-up or failure to stop.

Measures can be taken to minimise the consequences of single failures in interlocking systems. These MAY include the use of additional control or monitoring circuits. However, the system as a whole can still fail due to multiple undetected failures, e.g. common cause failures or undetected failures followed by further failure.

Common cause failures may typically result from:

- a) external environment e.g. contamination from dust, electrical disturbances, extreme temperatures, vibration or radiation;
- b) components from a substandard batch being used in each channel;
- c) damage due to localised fire or impact.

F.8.5 Security of interlocking systems

The security of an interlocking system can be improved by avoiding motives for its defeat and/or by making defeat more difficult.

The design of the safeguarding system should have taken full account of the need for human intervention in the machine during any phase of its life.

Ways in which defeat may be made more difficult include:

- a) the use of interlocking devices or systems which are coded;
- b) physical obstruction or shielding of the interlocking device while the guard is open.

F.8.6 Integrity of interlocking systems

The integrity of an interlocking system will depend not only on the direct effects of failures or defeats, but also whether or not those failures or defeats lead to damage to other components or interconnections within the system. Therefore, an important consideration should be circuit protection.

Other basic criteria for improving the integrity of an interlocking system include:

- a) correct installation;
- b) good quality, high integrity components, protected to withstand the environment (including possible reflections of laser energy) and rated for the duty they have to perform;
- c) minimising by design, manufacture and correct installation, the probability of an earth fault occurring;
- d) minimising failure to danger;
- e) minimising defeat.

F.8.7 Choice of interlocking system

Interlocking systems should be selected for particular applications taking account of:

- a) the frequency with which approach to the danger zone is required;
- b) the probability and severity of injury should the interlocking system fail;
- c) the resources required to reduce the risk of injury.

F.8.8 Electrical considerations

Electrical control systems can fail in ways that could result in hazardous situations. Particular attention should be paid to minimising the probability of this occurring. IEC 60204-1 gives guidance.

Devices should be selected only from those where the performance, as stated by the manufacturer, is suitable for the specific safety application. The following performance data should be considered:

- a) resistance to environmental conditions;
- b) life evaluation;
- c) duty rating;
- d) reliability.

Proximity switches which rely solely on the presence or absence of metal for their actuation are not generally suitable for interlocking duties because they can be easily defeated. However with careful design, these devices can be incorporated into difficult to reach or small assemblies. Extreme care must be taken to prevent the devices being defeated and suitable redundancy used to prevent common cause failures resulting in an overall failure to danger.

F.8.9 Mechanical considerations

F.8.9.1 Interlocking devices

Mechanical devices for connecting guard movement with the machine power or control system can take various forms but will generally perform the same function. They will usually be arranged so that operation of the guard and the machine can only be carried out in a correct safe sequence.

F.8.9.2 Mechanical interlocking methods

Unlike electrical, hydraulic or pneumatic systems, it is unusual for mechanical systems to be other than a single-control system.

The basic elements of single-control system interlocking are:

- a) the actuating device operated by the guard;
- b) interposed mechanical linkages, if any;
- c) the device for preventing the emission of laser radiation or preventing the power to any other hazard.

Reducing the number of interposed linkages reduces the probability of the system failing to danger.

F.8.10 Pneumatic and hydraulic considerations

F.8.10.1 Interlocking devices

Devices used for interfacing guard movement include:

- a) cam-operated valves;
- b) captive-key valves; tapped-key control of pneumatic valves;
- c) pneumatic jet detection valves;
- d) pneumatically or hydraulically operated locks.

When valves are selected for safeguarding applications, the valve operating parameters (pressure, temperature etc.) and reliability should be suitable for the environment and the duty envisaged.

F.8.10.2 Pneumatic or hydraulic interlocking methods

In general, interlocking methods as described earlier are applicable. These methods include:

- a) single-control system interlocking;
- b) dual-control system interlocking with or without cross-monitoring;
- c) power interlocking.

All piping, hoses, etc., between control valves and interlocks, should be suitable for the fluid and operating environment, correctly sized and rated for maximum flow and pressure and, where necessary, further effectively protected and securely mounted. Pipework fittings should be selected to ensure their integrity does not compromise the overall integrity of the interlocking system.

F.9 Environmental considerations

F.9.1 Environment

The selection of a safeguard should take into consideration the environment in which it is used. In a hostile environment it should be capable of withstanding the conditions likely to be experienced and should not of itself create a hazard as a result of that environment.

F.9.2 Corrosion

If a guard is likely to be exposed to a corrosion risk, special measures should be taken. The use of corrosion-resistant materials or corrosion-resistant surface coatings should be considered.

F.9.3 Hygiene and guard design

Guards used in certain industries, notably for processing of food or pharmaceuticals, should be so designed that they are not only safe to use but can be readily cleaned. Materials used for safeguards should be non-toxic, non-absorbent, shatterproof and readily cleanable and be unaffected by the material being processed or by cleaning or sterilising agents.

F.9.4 Mist, fumes and dust

Where the process gives rise to hazardous or objectionable levels of vapours, fumes or dust, containment or suitable extraction equipment should be provided. The levels of exposure to vapours, fume or dust should conform to the occupational exposure limits and occupational exposure standards for local control of substances hazardous to health.

F.9.5 Noise

Consideration should be given to noise reduction when designing safety enclosures and guards. It is often possible for guard enclosures to be designed to serve a dual purpose of protecting against laser radiation hazards together with mechanical hazards and reducing noise emissions. Guards should not add to the noise levels because of poor design or fixing.

F.10 Installation consideration - Environmental factors - Services

F.10.1 Lighting

When considering the lighting in relation to the laser processing machine the following aspects affect the safety of the people involved:

the direction and intensity of the light;

the contrast between the background and local illumination;

the colour of the light source;

reflection, glare and shadows;

the visual wavelength transmission characteristics of viewing windows.

F.10.2 Cables and pipes

Service pipes and cables should either be placed outside of the process zone or, when this is not possible, provided with covers of adequate strength and capable of tolerating laser radiation exposure under foreseeable fault conditions.

F.11 Maintenance and service considerations

F.11.1 Operational maintenance of safeguards

The maintenance of safeguards, once they are taken into use, is essential to their continued effectiveness.

There should be regular inspection of safeguards to ensure that the requisite standard of safety is maintained. The routine inspection of safeguards should be made as part of a planned maintenance programme.

F.11.2 Properties of laser guard materials

By way of illustration, Figures F.1 to F.22, provide some experimentally-determined limits of laser beam power and beam diameter for burn-through times of 10s or 100s for various metal sheets: the sheets were mounted vertically and the front surface painted black; and the laser beam was horizontal. 'Burn-through time' is the time taken for the laser beam to remove the material in its path (e.g. by melting, vaporisation, ablation) and the data should be taken only as a guide, since values can vary widely depending on the beam parameters (including wavelength and beam profile) and the condition of the guard surface.

The performance of a laser guard may also be dependant on its particular design and application; and it is recommended that the suitability of a laser guard design is verified by adequate performance testing.

Some examples of various guard materials are shown in the Figures on the following pages

Figure F.1 – 1 mm thick zinc coated steel sheet for CW CO₂ laser

Figure F.2 – 1 mm thick zinc coated steel sheet for CW CO₂ laser

Figure F.3 – 2 mm thick zinc coated steel sheet for CW CO₂ laser

Figure F.4 – 2 mm thick zinc coated steel sheet for CW CO₂ laser

Figure F.5 – 3 mm thick zinc coated steel sheet for CW CO₂ laser

Figure F.6 – 3 mm thick zinc coated steel sheet for CW CO₂ laser

Figure F.7 – 2 mm thick aluminium sheet for CW CO₂ laser

Figure F.8 – 2 mm thick aluminium sheet for CW CO₂ laser

Figure F.9 – 1 mm thick stainless steel sheet for CW CO₂ laser

Figure F.10 – 1 mm thick stainless steel sheet for CW CO₂ laser

Figure F.11 – 6 mm thick polycarbonate steel sheet for CW CO₂ laser

Figure F.12 – 6 mm thick polycarbonate steel sheet for CW CO₂ laser

Figure F.13 – 1 mm thick zinc coated steel sheet for CW Nd:YAG laser

Figure F.14 – 1 mm thick zinc coated steel sheet for CW Nd:YAG laser

Figure F.15 – 2 mm thick zinc coated steel sheet for CW Nd:YAG laser

Figure F.16 – 2 mm thick zinc coated steel sheet for CW Nd:YAG laser

Figure F.17 – 3 mm thick zinc coated steel sheet for CW Nd:YAG laser

Figure F.18 – 3 mm thick zinc coated steel sheet for CW Nd:YAG laser

Figure F.19 – 2 mm thick aluminium steel sheet for CW Nd:YAG laser

Figure F.20 – 2 mm thick aluminium steel sheet for CW Nd:YAG laser

Figure F.21 – 1 mm thick stainless steel sheet for CW Nd:YAG laser

Figure F.22 – 1 mm thick stainless steel sheet for CW Nd:YAG laser

<http://www.china-gauges.com/>

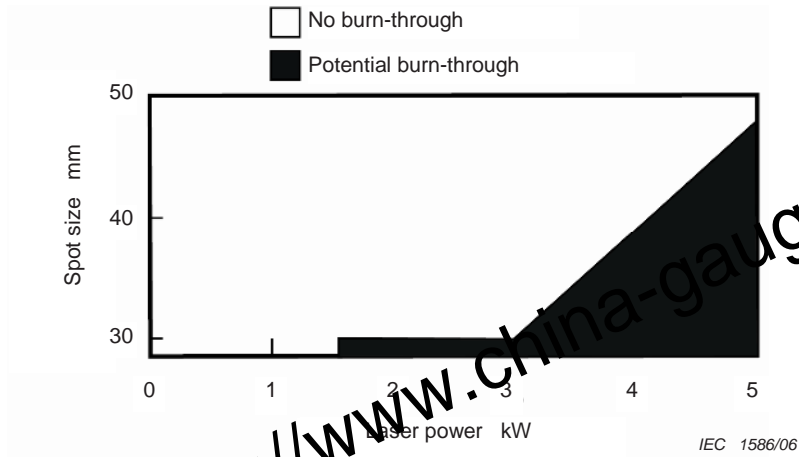

Figure F.1 – Damage resistance of 1 mm thick zinc coated steel sheet derived from 10 s exposure to a defocused beam during experiments using a CW CO₂ laser

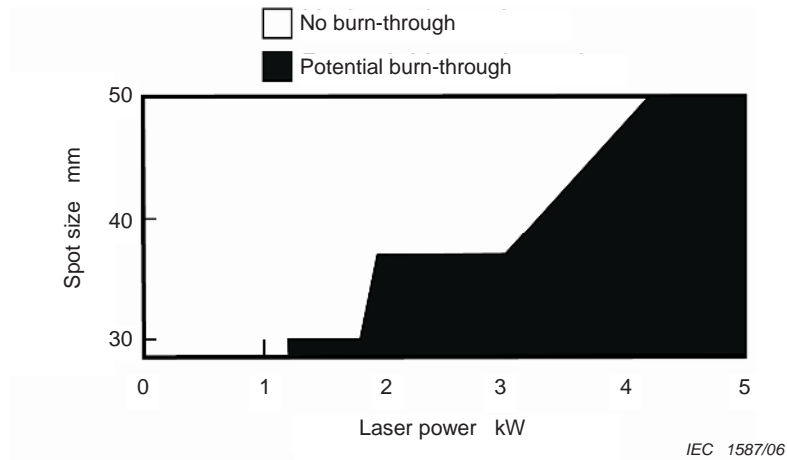

Figure F.2 – Damage resistance of 1 mm thick zinc coated steel sheet derived from 100 s exposure to a defocused beam during experiments using a CW CO₂ laser

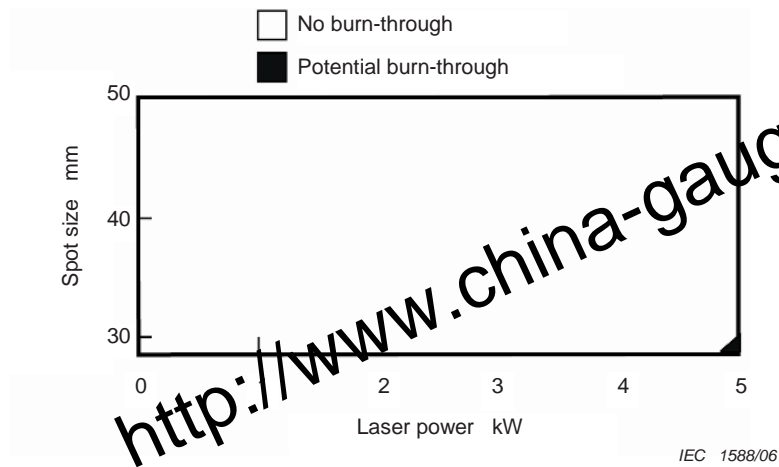

Figure F.3 – Damage resistance of 2 mm thick zinc coated steel sheet derived from 10 s exposure to a defocused beam during experiments using a CW CO₂ laser

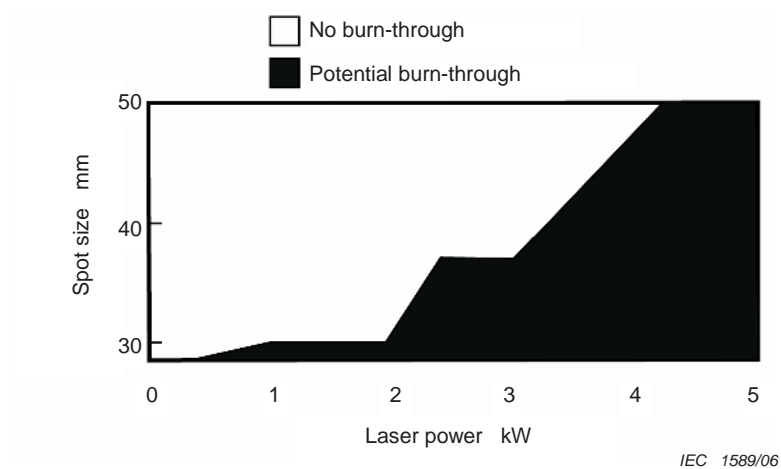
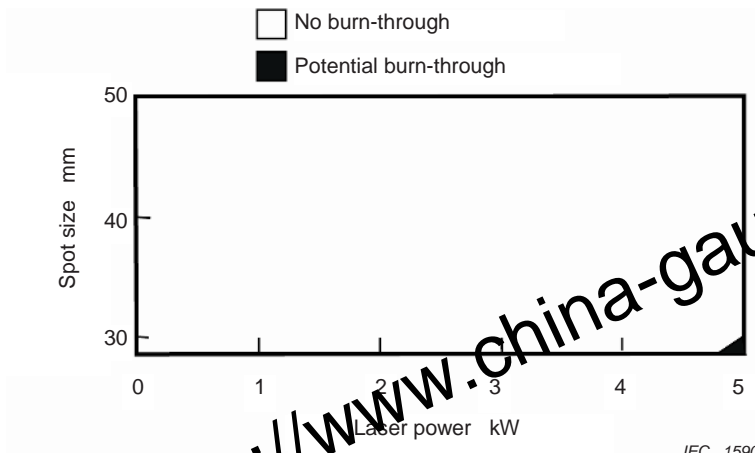

Figure F.4 – Damage resistance of 2 mm thick zinc coated steel sheet derived from 100 s exposure to a defocused beam during experiments using a CW CO₂ laser



IEC 1590/06

<http://www.china-gauges.com/>

Figure F.5 – Damage resistance of 3 mm thick zinc coated steel sheet derived from 10 s exposure to a defocused beam during experiments using a CW CO₂ laser

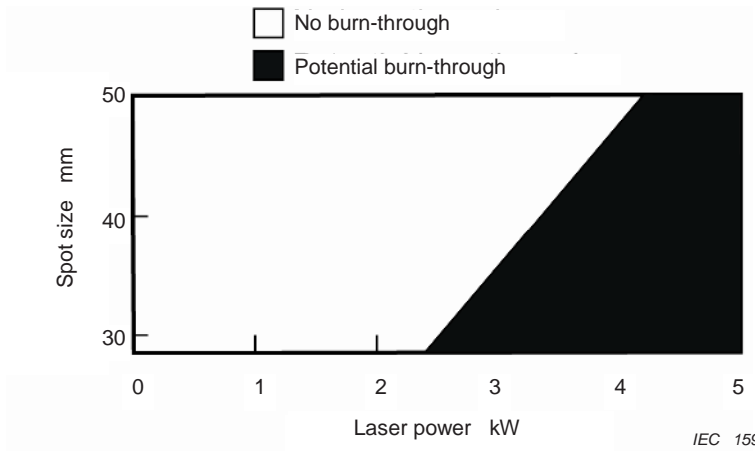

IEC 1591/06

Figure F.6 – Damage resistance of 3 mm thick zinc coated steel sheet derived from 100 s exposure to a defocused beam during experiments using a CW CO₂ laser

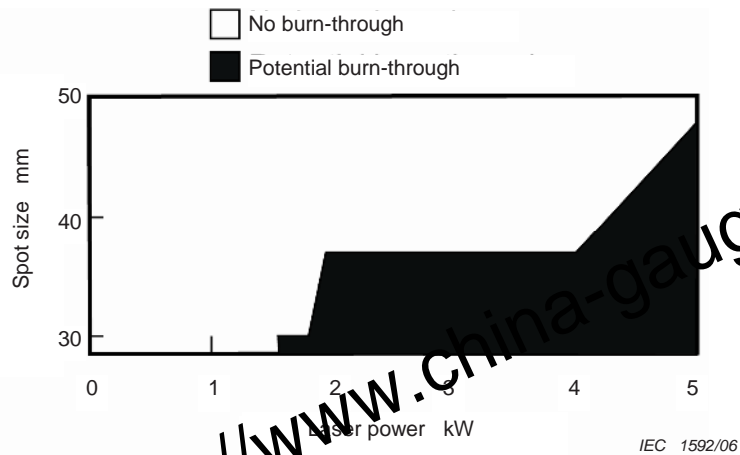

Figure F.7 – Damage resistance of 2 mm thick aluminium sheet derived from 10 s exposure to a defocused beam during experiments using a CW CO₂ laser

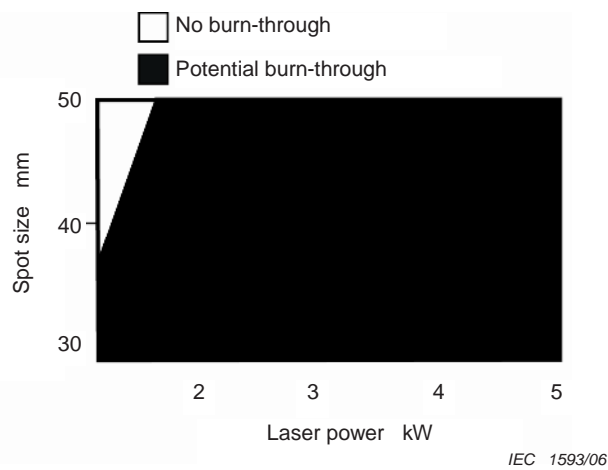

Figure F.8 – Damage resistance of 2 mm thick aluminium sheet derived from 100 s exposure to a defocused beam during experiments using a CW CO₂ laser

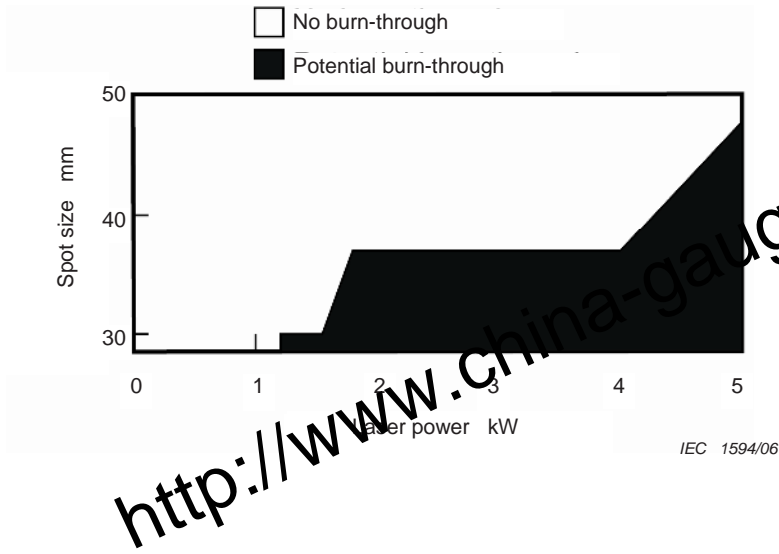

Figure F.9 – Damage resistance of 1 mm thick stainless steel sheet derived from 10 s exposure to a defocused beam during experiments using a CW CO₂ laser

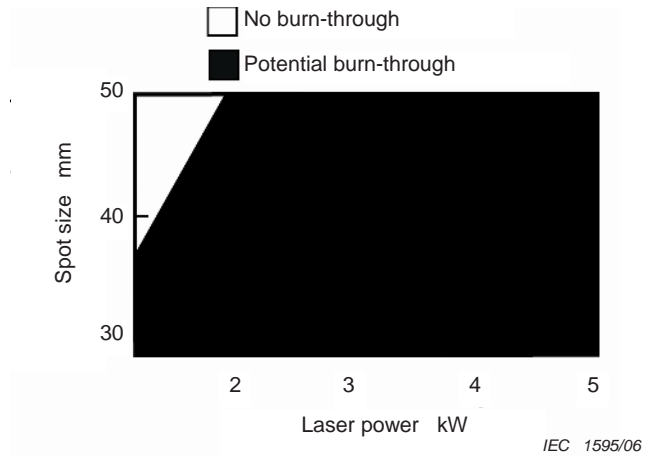

Figure F.10 – Damage resistance of 1 mm thick stainless steel sheet derived from 100 s exposure to a defocused beam during experiments using a CW CO₂ laser

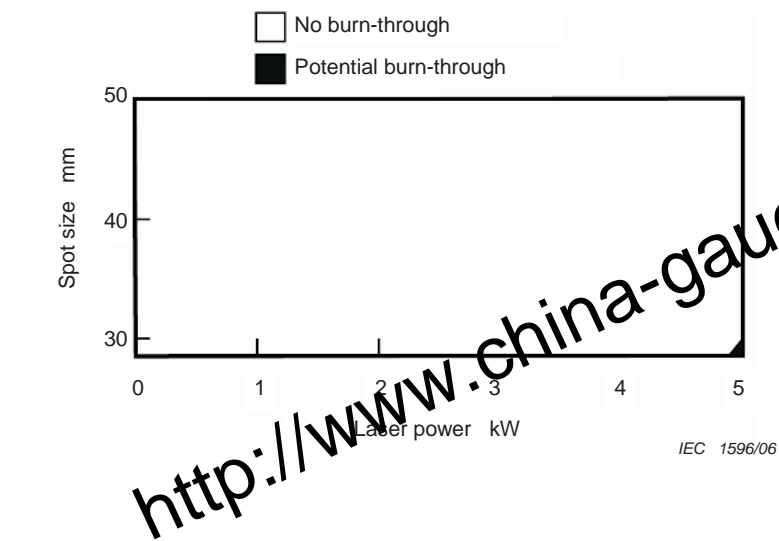

Figure F.11 – Damage resistance of 6 mm thick polycarbonate sheet derived from 10 s exposure to a defocused beam during experiments using a CW CO₂ laser

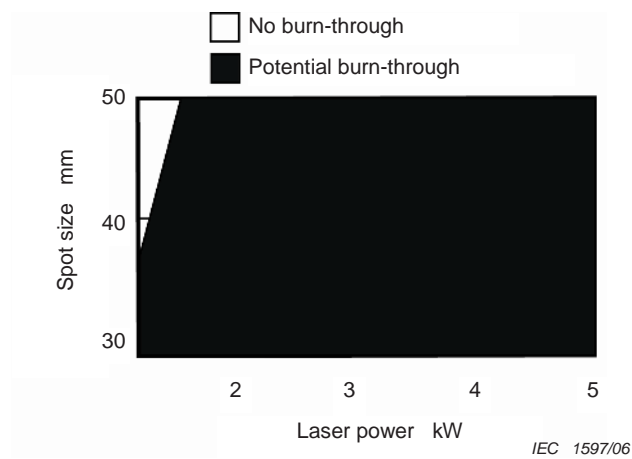

Figure F.12 – Damage resistance of 6 mm thick polycarbonate sheet derived from 100 s exposure to a defocused beam during experiments using a CW CO₂ laser

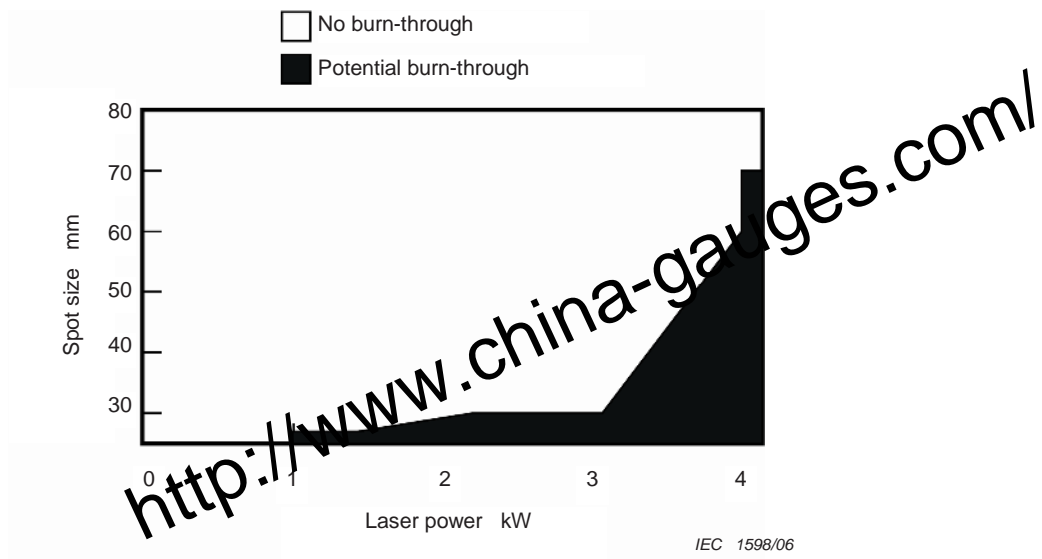

Figure F.13 – Damage resistance of 1 mm thick zinc coated steel sheet derived from 10 s exposure to a defocused beam during experiments using a CW Nd:YAG laser

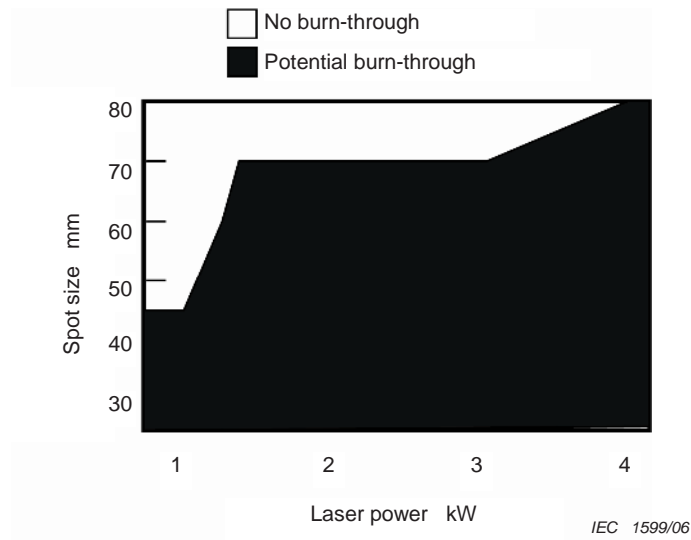

Figure F.14 – Damage resistance of 1 mm thick zinc coated steel sheet derived from 100 s exposure to a defocused beam during experiments using a CW Nd:YAG laser

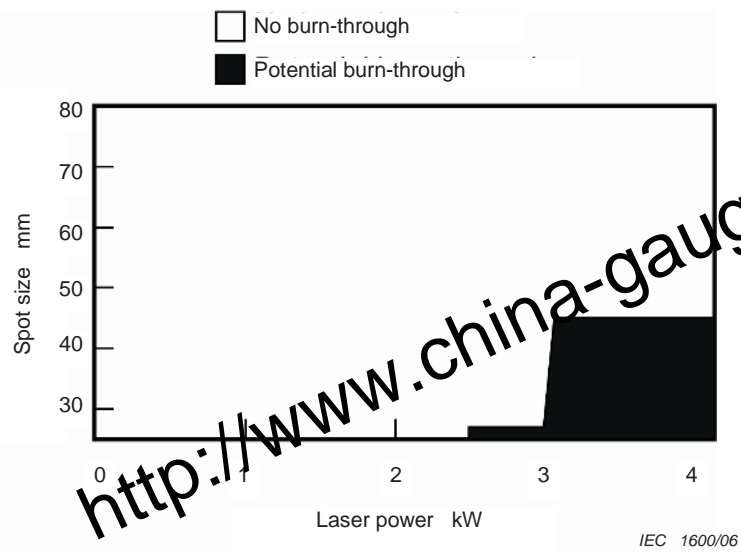

Figure F.15 – Damage resistance of 2 mm thick zinc coated steel sheet derived from 10 s exposure to a defocused beam during experiments using a CW Nd:YAG laser

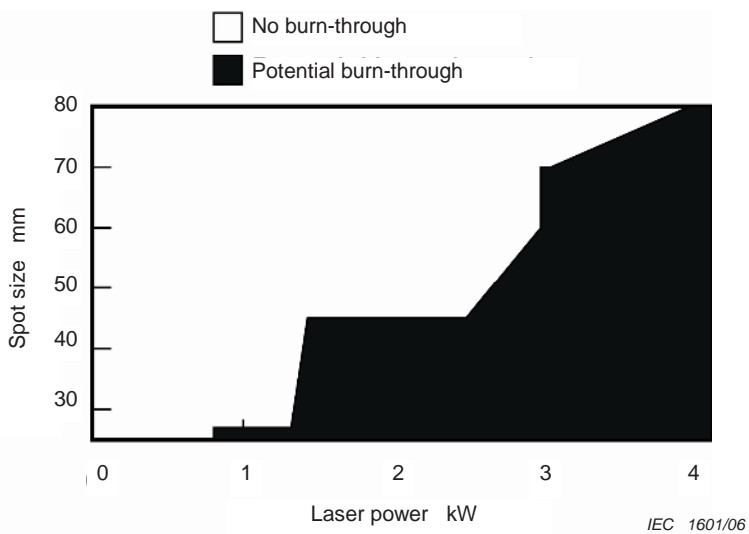

Figure F.16 – Damage resistance of 2 mm thick zinc coated steel sheet derived from 100 s exposure to a defocused beam during experiments using a CW Nd:YAG laser

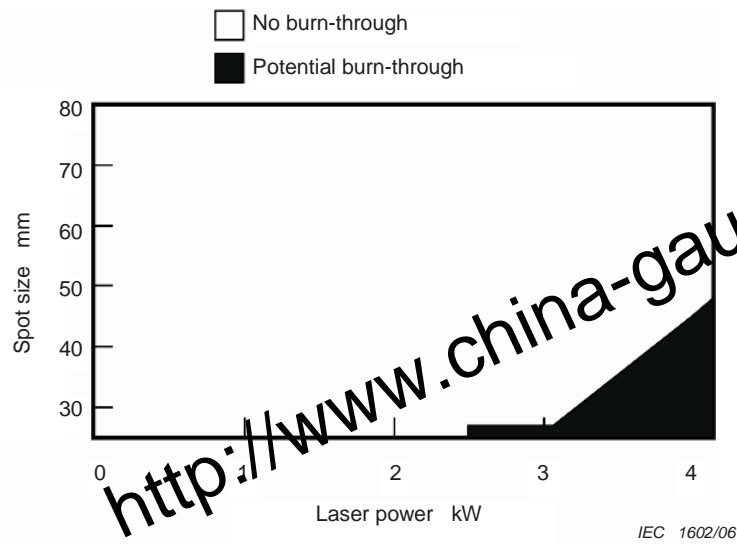

Figure F.17 – Damage resistance of 3 mm thick zinc coated steel sheet derived from 10 s exposure to a defocused beam during experiments using a CW Nd:YAG laser

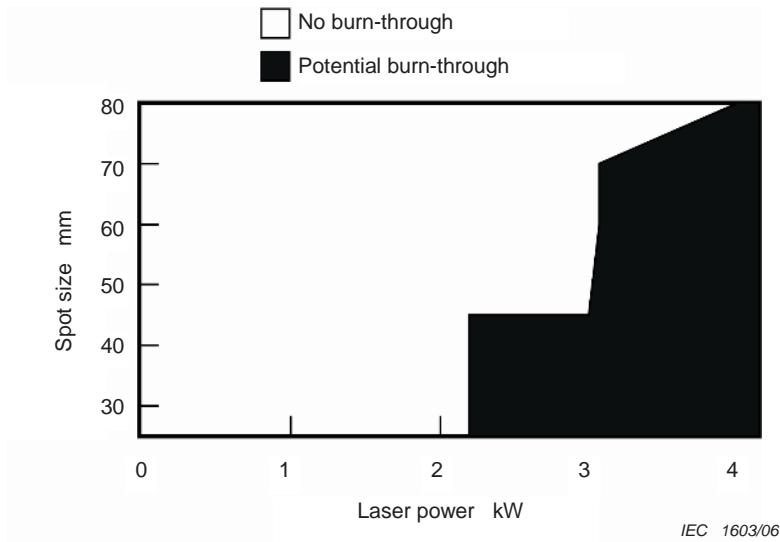

Figure F.18 – Damage resistance of 3 mm thick zinc coated steel sheet derived from 100 s exposure to a defocused beam during experiments using a CW Nd:YAG laser

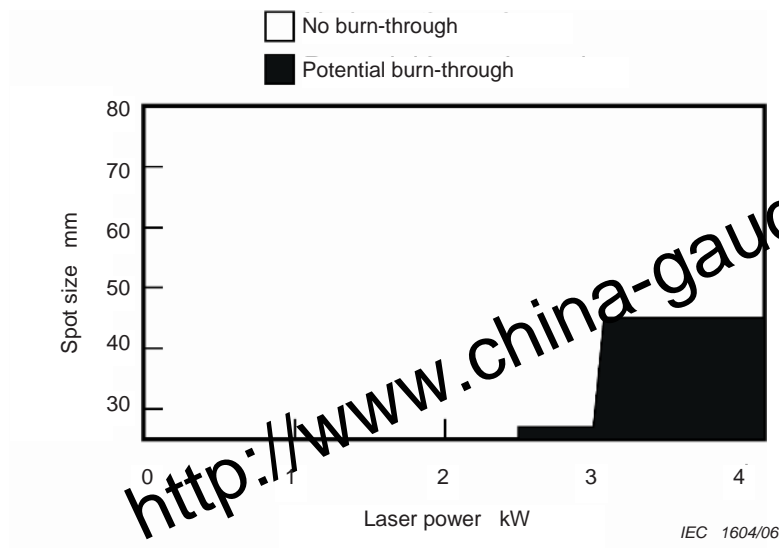

Figure F.19 – Damage resistance of 2 mm thick aluminium sheet derived from 10 s exposure to a defocused beam during experiments using a CW Nd:YAG laser

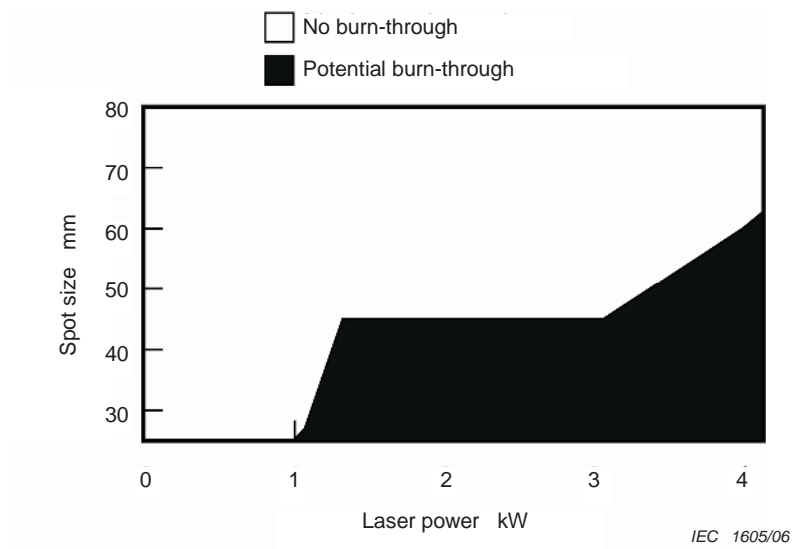

Figure F.20 – Damage resistance of 2 mm thick aluminium sheet derived from 100 s exposure to a defocused beam during experiments using a CW Nd:YAG laser

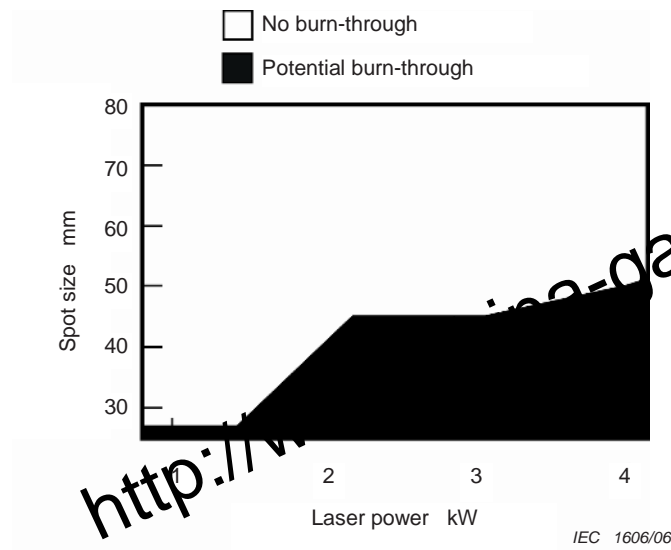

Figure F.21 – Damage resistance of 1 mm thick stainless steel sheet derived from 10 s exposure to a defocused beam during experiments using a CW Nd:YAG laser

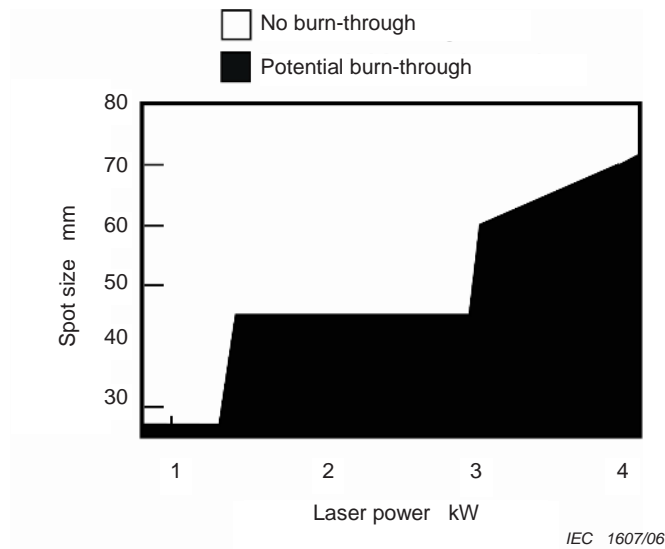

Figure F.22 – Damage resistance of 1 mm thick stainless steel sheet derived from 100 s exposure to a defocused beam during experiments using a CW Nd:YAG laser



Annex G (normative)

Beam delivery systems

G.1 General

This normative annex addresses the arrangement, installation and use of guided beam delivery systems. Laser beams can be propagated through air, gas or vacuum, whether enclosed or not (free space), and through fibre optic cables in laser processing machine applications.

This annex applies to the protective measures implemented to protect personnel against laser radiation hazards for guided beam delivery systems after the output coupler and/or the protective housing of the laser product (the requirements of which are specified in IEC 60825-1). This annex is intended to compliment the requirements applicable to the laser process enclosure (which are specified in this document and in ISO 11553-1). This annex also provides methods for assessing the risks (including reasonably foreseeable use, abuse and misuse) and provides examples of control measures to meet the normative requirements of IEC 60825-1 and this document.

This annex does not apply to beam delivery systems inside the protective housing of the laser.

This annex does not apply to beam delivery systems used in medical or communications applications.

G.2 Terms and definitions

For the purposes of this annex, the following definitions apply. They are in addition to those given in IEC 60825-1 or other parts of IEC 60825.

G.2.1

access panel

any panel which when removed or displaced gives human access to laser radiation. Sheathing around a fibre, tubing used as an enclosure component or any device serving the function of a removable or displaceable panel, can also be an "access panel" within the terms of this definition

G.2.2

beam delivery system

system comprised of all those components, including all optical beam components and potential beam paths and their enclosures, which when combined, transfer laser radiation emitted from the laser radiation generator (the laser) to the workpiece. These components may include all elements for guiding, shaping and switching the laser beam as well as the enclosure of and support for the beam path components

G.2.3

beam path components

those optical components which lie on a defined beam path (see 3.16 of IEC 60825-1)

NOTE Examples of a beam path component include a beam steering mirror, a focus lens or a fibre optic cable connector.

A1

G.2.4

beam shaping components

those optical components introduced in the beam path to transform the profile or cross-section of the laser beam by means of apertures, reflective, refractive or diffractive optical components

G.2.5

beam switching components

those optical components or an assembly of components introduced in the beam path to direct or divert, under external control, the beam path along a predetermined direction(s). The external control allows the beam path to be switched from one predetermined direction to another

G.2.6

fibre optic cable

optical beam guiding component that enables the transmission of laser radiation along a transparent medium. A fibre optic cable may have a glass or other core that carries the laser radiation and be surrounded by cladding. The outside of the fibre is protected by cladding and may be further protected by additional layers of other material such as a polymer or a metal to protect the fibre from mechanical deformation, the ingress of water, etc. For this annex, this term also includes other forms of transmission devices such as waveguides

G.3 General requirements

G.3.1 General considerations

The risks associated with the hazards relevant to the beam delivery systems shall be assessed as part of the overall requirements for risk assessment of the machine. The principles for risk assessment given in standard ISO 14121-1 shall be used in carrying out this assessment. This assessment shall determine the acceptable level of risk and the necessary protective measures for persons who can be exposed to those hazards, while maintaining an acceptable level of performance of the machine.

Hazards can result from, but are not limited to, the following causes:

- failures, faults or damage in the protective housing or other mechanical protective measures incorporated in the beam delivery system resulting in the inadvertent emission of laser radiation from the protective housing;
- failures or faults in the beam path components resulting in damage to the protective housing or other protective devices;
- failures or faults in the associated equipment or controls resulting in injury or malfunction or failure of the safety functions of the laser processing machine;
- failures or faults from reasonably foreseeable misuse or abuse resulting in the inadvertent emission of laser radiation from the protective housings.

The engineering and administrative controls adopted are a combination of the measures incorporated at the design stage and include those instructions to be followed by the user.

Design shall be the first consideration in the reduction of risks. Where this is not sufficient to eliminate risks to a negligible level, additional safeguarding and safe working procedures shall be considered.

NOTE Examples of risk assessments and potential solutions for risk reduction measures are shown in Clause G.6.

G.3.2 Protective housing

The requirements for protective housing are specified in 4.2.1 and 4.2.2 of IEC 60825-1. **A1**

Ⓐ

G.3.3 Access panels and safety interlocks for beam delivery systems using free space transmission

The requirements for access panels and safety interlocks are specified in IEC 60825-1 Clause 4.3.

A safety interlock shall be provided for access panels of protective housings of free space beam delivery systems that may include beam shaping and beam switching components when:

- a) The access panel is intended to be removed or displaced during maintenance or operation of the laser processing machine, and
- b) The removal of the panel gives access to laser radiation levels designated by “X” in Table 1 of IEC 60825-1.

The safety interlock shall be part of a design that prevents the removal of the panel until the accessible emission levels are below the AEL defined above. Inadvertent resetting of the interlock shall not in itself restore emission values above the limits specified above.

If a deliberate override mechanism is provided, the requirements of 4.3.2 of IEC 60825-1 shall apply.

All safety interlocks, safety monitoring devices or associated safety-related control circuits shall meet the requirements specified in ISO 12100-2 and ISO 13849-1 with respect to the general requirements for guards together with the requirements related to interlock devices and safety monitoring devices and their application in safety-related control circuits.

G.3.4 Safety interlocks for beam delivery systems using fibre optic cables or other beam waveguides

Removal or displacement of a fibre optic cable (or other form of beam waveguide) in a beam delivery system shall be allowable only under at least one of the following conditions.

- a) With the use of a key or tool at the point of connection to allow access, removal or displacement of the fibre optic cable by skilled or trained persons.
- b) With the prevention of emission from the fibre optic cable by the termination of emission from the laser prior to access to the fibre optical cable end on the removal or displacement of the fibre optic cable. This may be accomplished by the use of interlocks at the interfaces that can be displaced.
- c) Removal or displacement of the fibre optic cable without the use of a key or special tool and without the termination of laser radiation emission from the laser shall be possible only when other protective measures are provided to ensure that personnel are not exposed to laser radiation that will cause injury. These protective measures shall be clearly described in the user instructions together with the necessary procedures for their use.

When a safety interlock is used, removal of the protective housing shall not permit human access to accessible emission levels above the applicable AEL in Table 1 of IEC 60825-1. Inadvertent resetting of the interlock shall not in itself restore emission values above the applicable AEL in Table 1 of IEC 60825-1. These interlocks shall be failsafe or redundant and conform to the requirements in the applicable IEC product standard.

If a deliberate override mechanism is provided, the requirements of 4.3.2 of IEC 60825-1 shall apply.

All safety interlocks, safety monitoring devices or associated safety-related control circuits shall meet the requirements specified in ISO 12100-2 and ISO 13849-1 with respect to the Ⓐ

A1

general requirements for guards together with the requirements related to interlock devices and safety monitoring devices and their application in safety-related control circuits.

G.3.5 Environmental conditions

All beam delivery systems shall meet the safety requirements defined in this annex under all expected operating conditions and foreseeable abuse and misuse appropriate to the intended purpose of the laser processing machine. Factors to be considered shall include:

- the intended environment of use;
- climatic conditions (e.g. temperature, relative humidity, etc.);
- anticipated vibration and shock;
- electromagnetic interferences.

G.4 Verification of safety requirements or protective measures

General conformance with the requirements of this annex shall be by visual inspection.

Correct functioning of control devices shall be verified according to functional tests specified by the manufacturer.

Verification procedures relating to laser radiation levels shall conform to IEC 60825-1.

Verification of the information for the user shall be confirmed by visual examination of the handbooks and any other relevant information.

G.5 Information for users

G.5.1 Technical documentation

In addition to the requirements of other standards that are used in the manufacture of the laser processing machine, the following information shall be supplied.

- a) Relevant safety-related documentation and details of safe installation and use of the beam delivery system. This shall, where appropriate, include:
 - 1) a clear, comprehensive description of the beam delivery system, its installation and mounting and any connection to the host equipment safety-related controls;
 - 2) electrical supply and other control requirements;
 - 3) laser radiation performance limitations;
 - 4) information on the relevant physical environment.
- b) Relevant safety-related documentation for maintenance and servicing procedures associated with the beam delivery system. This information shall include guidance on the adjustment, maintenance, replacement and repair, particularly of the protective devices and control for use by authorised service personnel.
- c) List of recommended spare parts for use by authorised service personnel.
- d) A description (including interconnection diagrams) of the safeguards, interlocking functions and interlocking of guards. This description shall include situations when removal or displacement of the fibre optic cable without the use of a key or special tool and without the termination of laser radiation emission from the laser shall be possible and when other protective measures are provided to ensure that personnel are not exposed to laser radiation that will cause injury. These protective measures shall be clearly described together with the necessary procedures for their use.
- e) A description of the means provided, where it is necessary, to suspend the safeguarding. **A1**

Ⓐ

G.5.2 Labelling

Access panel warning labels shall be fitted as required and described in Clause 5 of IEC 60825-1.

G.6 Examples of risk assessments

Examples of risk assessments are shown below together in Tables G.1 and G.2 with potential solutions for risk reduction measures. The list is not comprehensive and alternative technical measures (that may have identical or improved efficiency) for risk reduction can be considered. Ⓐ

<http://www.china-gauges.com/>

A1

Table G.1 – Beam delivery systems using free space beam delivery systems

Use, reasonably foreseeable misuse or abuse	Failure mechanism	Hazard	Example of risk reduction
Beam directed through beam switching device.	Beam switch emits the laser beam partly or wholly guided to an unexpected beam delivery system.	Laser radiation above Accessible Emission Limit (AEL) of Class 1 at unexpected beam delivery system.	Design the beam switching device to avoid this.
Beam directed through beam switching device.	Beam switch not in proper position - laser beam partly or wholly guided to unexpected beam delivery system.	Laser radiation above AEL of Class 1 at unexpected beam delivery system.	Monitor the beam switching device and interlock to ensure the beam switch components are in the correct positions.
Beam being propagated through the free space beam path protective housing.	Mirror or lens damage, breakage, contamination leading to higher degree of scattered radiation that may cause deformation of components in the beam delivering system.	Laser radiation above AEL of Class 1 from openings in beam delivery system.	The beam delivery protective housing to be able to tolerate the Foreseeable Exposure Limit (FEL) (as defined in 3.4 of this standard) as a passive guard, or use a correctly designed active guard considered. Consider apertures to reduce the amount of radiation scattered from a defective mirror, or limit radiation scattered as a result of misalignment. Monitor the local temperature of vulnerable beam delivery components.
Beam being propagated through the free space beam path protective housing.	Mirror breakage leading to excess heating by the laser beam resulting in the deformation of components in the beam delivering system.	Laser radiation above AEL of Class 1 from openings in beam delivery system.	The beam delivery protective housing to be able to tolerate the FEL as passive guard, or use a correctly designed active guard considered. Consider apertures to reduce the amount of radiation scattered from a defective mirror, or limit radiation scattered as a result of misalignment. Monitor the local temperature of vulnerable beam delivery components.
Beam being propagated through the free space beam path protective housing.	Mechanical deformations of protective housing. (Damage or deformation due to external forces great enough to temporarily or permanently distort the physical configuration.)	Laser radiation above AEL of Class 1 from openings in beam delivery system.	The beam path protective housing designed to tolerate reasonably foreseeable mechanical forces, or provide an alternative active guard.
Beam being propagated through the free space beam path protective housing.	Displacement of the protective housing due to vibrations etc. that may cause the beam delivery system break-up.	Laser radiation above AEL of Class 1 from openings in beam delivery system.	The use of well-tried proven design methods that tolerate foreseeable operating stresses and widely used with successful results in similar applications. Conduct regular inspection.

A1



Table G.1 (continued)

Use, reasonably foreseeable misuse or abuse	Failure mechanism	Hazard	Example of risk reduction
Beam being propagated through the free space beam path protective housing.	Misalignment of mirrors.	The beam exposing the protective housing to levels higher than its Protective Exposure Limit (PEL) (as defined in 3.3 of this standard).	<p>The use of well-tryed proper design methods that generate foreseeable operating stresses and are widely used with successful results in similar applications.</p> <p>Prevent misaligned beam from propagating further in the beam delivery system.</p> <p>Incorporate apertures and baffles/barriers to restrict propagation.</p> <p>Restrict the number and extent of adjustments.</p>
Beam being propagated through the free space beam path protective housing.	Unclear identification of beam delivery components resulting in incorrect parts being installed and subsequent damage of both the parts themselves and other parts of the machine or workpiece.	<p>Laser radiation above AEL of Class 1 from openings in beam delivery system.</p> <p>Damage to associated parts of the machine.</p>	<p>Ensure that all beam delivery system components and parts are labelled to allow easy identification.</p> <p>Provide adequate instructions to minimise the risk of using incorrect parts or of incorrect assembly or adjustment.</p> <p>Incorporate interlocks to prevent incorrect parts or assembly.</p>
Incorrect mounting of beam shaping optics.	Human error.	Laser radiation above AEL of Class 1 (by escaping the protected laser area, or exceeding the laser guard PEL).	<p>Provide adequate instructions to minimise the risk of using incorrect parts or of incorrect assembly or adjustment.</p> <p>Conduct regular inspections.</p>
Damage of beam shaping optics.	From collision with workpiece, overheated optics due to contamination or cooling water failure.	Laser radiation above AEL of Class 1 (by escaping the protected laser area, or exceeding the laser guard PEL).	<p>Ensure that all beam delivery system components and parts are labelled to allow easy identification.</p> <p>Provide adequate instructions to minimise the risk of using incorrect parts or of incorrect assembly or adjustment.</p> <p>Incorporate interlocks or mechanical location keys to prevent the use of incorrect parts or incorrect assembly.</p> <p>Monitor the local temperature of vulnerable beam delivery components</p>



Table G.2 – Beam delivery systems using fibre optic cables

Use, reasonably foreseeable misuse or abuse	Possible failure mechanism	Hazard	Examples of risk reduction
Beam directed through beam switching device.	Beam switch "leaks" - laser beam partly or wholly guided to unexpected beam delivery system.	Laser radiation above AEL of Class 1 at unexpected beam delivery system.	Design the beam switching device to avoid this.
Beam directed through beam switching device.	Beam switch not in the correct position - laser beam partly or wholly guided to unexpected beam delivery system.	Laser radiation above AEL of Class 1 at the unexpected beam delivery system.	Monitor the beam switching device and interlock to ensure the beam switch components are in the correct positions.
Beam being coupled into fibre.	Damage (i.e. thermal) to coupling optics.	The coupling optical components or assemblies overheat to a degree where it damages or deforms resulting in either leaking radiation or the production of errant beams.	The coupling optical components or assemblies to be designed to handle power passively. Interlock of the beam. Monitor component temperature and interlock into the control system.
Beam being coupled into fibre.	Damaged fibre at the input surface.	Fibre connector heats up to a degree where it deforms and laser radiation is not correctly coupled into the fibre.	Fibre connector designed to handle power passively. Introduce beam monitoring schemes and interlock into the control system.
Beam in fibre optic cable.	Breakage due to mechanical forces on the fibre.	Laser radiation above AEL of Class 1 emitted from a broken fibre to the surrounding. Possible fire hazard.	Fibre to be put inside protective cover that protects from mechanical forces in the operating environment and potential misuse/abuse. Use the protective housing to limit excessive twist. Provide strain relief at the optical fibre terminations to minimise bending and twisting. Make the protective housing active guard linked into the control system (see IEC 60825-4). Monitor component temperature and interlock into the control system.
With the laser beam being directed through the fibre optic, the fibre is subjected to repetitive flexing.	Breakage due to fatigue.	Laser radiation above AEL of Class 1 emitted from a broken fibre to the surrounding.	Design the protective housing to restrict the bending radius to prevent fibre breakage. Provide strain relief at the optical fibre terminations to minimise bending and twisting. Design a reinforced protective housing to be able to tolerate the laser radiation of the inner surface at the protective housing. Make the protective housing active guard linked into the control system (see IEC 60825-4).

Table G.2 (continued)

Use, reasonably foreseeable misuse or abuse	Possible failure mechanism	Hazard	Examples of risk reduction
With the laser beam being directed through the fibre optic, the fibre is subjected to repetitive flexing.	Breakage due to other than mechanical forces (optical degrading, first pulses etc.)	Laser radiation above AEL of Class 1 from a broken fibre to the surrounding environment.	The protective housing to be able to retain the laser radiation on the inner surface of the protective housing without breakthrough. Make the protective housing active guard linked into the control system (see IEC 60825-4).
Unconnected fibre at the output of the fibre optic cable emitting laser radiation from the laser. Unconnected fibre at the input of the fibre optic cable emitting laser radiation from the laser.	Human error. Mechanical loosening of fixings due to incorrect assembly or vibrations, for example.	Laser radiation being emitted in an undefined and uncontrolled direction leading to potential exposure above AEL of Class 1 (by escaping the laser guarded area, or exceeding any other laser guard PEL).	Interlock the fibre interface/connector. Ensure that the fixings and associated tools used to mount/dismount fibre interface are adequate. Minimise the requirement for the interface to be interfered with. Restrict this activity to service work carried out by skilled and authorised personnel with special training. Design a reinforced laser guard.
Incorrect mounting of beam shaping optics.	Human error.	Laser radiation being emitted in an undefined and uncontrolled direction leading to potential exposure above AEL of Class 1 (by escaping the laser guarded area, or exceeding any other laser guard PEL).	Ensure design is adequately robust. Ensure instructions are sufficient for adjustments to be made securely. Recommend inspection intervals.
Damage of beam shaping optics.	From collision with workpiece, overheated optics due to contamination or cooling water failure.	Laser radiation being emitted in an undefined and uncontrolled direction leading to potential exposure above AEL of Class 1 (by escaping the laser guarded area, or exceeding any other laser guard PEL).	Design considerations to include the complete laser guard. Provide collision protection or interlocks.
Multiple fibres - mix of fibres.	Human error.	Laser radiation being emitted in an undefined and uncontrolled direction leading to potential exposure above AEL of Class 1 (by escaping the laser guarded area, or exceeding any other laser guard PEL).	Orientate, mechanically interlock or clearly and indelibly mark fibre optic cables. Ensure instructions are clear and unambiguous. If the fibre optic cables transmit the laser beam to separate laser guarded enclosures, interlock the enclosure together with the fibre optic cable.

Bibliography

IEC 60204-1, *Safety of machinery – Electrical equipment of machines – Part 1: General requirements*

NOTE Harmonized as EN 60204-1:2006 (modified).

IEC/TR 60825-14, *Safety of laser products – Part 14: A user's guide*

IEC 61310-3, *Safety of machinery – Indication, marking and operation – Part 3: Requirements for the location and operation of actuators*

NOTE Harmonized as EN 61310-3:1999 (not modified).

IEC 61496-2, *Safety of machinery – Electro-sensitive protective equipment – Part 2: Particular requirements for equipment using active opto-electronic protective devices (AOPDs)*

NOTE Harmonized as CLC/TS 61496-2:2006 (not modified).

IEC 62046, *Safety of machinery – Application of protective equipment to detect the presence of persons*

NOTE Harmonized as CLC/TS 62046:2005 (not modified).

ISO 10218:1992, *Manipulating industrial robots – Safety*

NOTE Harmonized as EN 775:1992 (modified).

A1 Text deleted. **A1**

ISO 14120, *Safety of machinery – Guards – General requirements for the design and construction of fixed and movable guards*

A1 Text deleted. **A1**

ISO 15532-3, *Safety of machinery – Human body measurements – Part 3: Anthropometric data*

A1 ISO 11252:2004, *Lasers and laser-related equipment – Laser device – Minimum requirements for documentation*

ISO 14119:1998, *Safety of machinery – Interlocking devices associated with guards – Principles for design and selection*

Amendment 1 (2007)

ISO TR 14121-2:2007, *Safety of machinery – Risk assessment – Part 2: Practical guidance and examples of methods* **A1**



Annex ZA
(normative)

**Normative references to international publications
with their corresponding European publications**

The following referenced documents are indispensable for the application of this document. For dated references, only the edition cited applies. For undated references, the latest edition of the referenced document (including any amendments) applies.

NOTE When an international publication has been modified by common modifications, indicated by (mod), the relevant EN/HD applies.

<u>Publication</u>	<u>Year</u>	<u>Title</u>	<u>EN/HD</u>	<u>Year</u>
IEC 60825-1	2007	Safety of laser products - Part 1: Equipment classification and requirements	EN 60825-1	2007
ISO 11553-1	2005	Safety of machinery - Laser processing machines - Part 1: General safety requirements	EN ISO 11553-1	2005
ISO 12100-1	2003	Safety of machinery - Basic concepts, general principles for design - Part 1: Basic terminology, methodology	EN ISO 12100-1	2003
ISO 12100-2	2003	Safety of machinery - Basic concepts, general principles for design - Part 2: Technical principles	EN ISO 12100-2	2003
ISO 13849-1	2006	Safety of machinery - Safety-related parts of control systems - Part 1: General principles for design	EN ISO 13849-1	2008
ISO 14121-1	2007	Safety of machinery - Risk assessment - Part 1: Principles	EN ISO 14121-1	2007



<http://www.china-gauges.com/>

BSI - British Standards Institution

BSI is the independent national body responsible for preparing British Standards. It presents the UK view on standards in Europe and at the international level. It is incorporated by Royal Charter.

Revisions

British Standards are updated by amendment or revision. Users of British Standards should make sure that they possess the latest amendments or editions.

It is the constant aim of BSI to improve the quality of our products and services. We would be grateful if anyone finding an inaccuracy or ambiguity while using this British Standard would inform the Secretary of the technical committee responsible, the identity of which can be found on the inside front cover. Tel: +44 (0)20 8996 9000. Fax: +44 (0)20 8996 7400.

BSI offers members an individual updating service called PLUS which ensures that subscribers automatically receive the latest editions of standards.

Buying standards

Orders for all BSI, international and foreign standards publications should be addressed to Customer Services. Tel: +44 (0)20 8996 9001. Fax: +44 (0)20 8996 7001 Email: orders@bsigroup.com You may also buy directly using a debit/credit card from the BSI Shop on the Website <http://www.bsigroup.com/shop>

In response to orders for international standards, it is BSI policy to supply the BSI implementation of those that have been published as British Standards, unless otherwise requested.

Information on standards

BSI provides a wide range of information on national, European and international standards through its Library and its Technical Help to Exporters Service. Various BSI electronic information services are also available which give details on all its products and services. Contact Information Centre. Tel: +44 (0)20 8996 7111 Fax: +44 (0)20 8996 7048 Email: info@bsigroup.com

Subscribing members of BSI are kept up to date with standards developments and receive substantial discounts on the purchase price of standards. For details of these and other benefits contact Membership Administration. Tel: +44 (0)20 8996 7002 Fax: +44 (0)20 8996 7001 Email: membership@bsigroup.com

Information regarding online access to British Standards via British Standards Online can be found at <http://www.bsigroup.com/BSOL>

Further information about BSI is available on the BSI website at <http://www.bsigroup.com>

Copyright

Copyright subsists in all BSI publications. BSI also holds the copyright, in the UK, of the publications of the international standardization bodies. Except as permitted under the Copyright, Designs and Patents Act 1988 no extract may be reproduced, stored in a retrieval system or transmitted in any form or by any means – electronic, photocopying, recording or otherwise – without prior written permission from BSI.

This does not preclude the free use, in the course of implementing the standard, of necessary details such as symbols, and size, type or grade designations. If these details are to be used for any other purpose than implementation then the prior written permission of BSI must be obtained.

Details and advice can be obtained from the Copyright and Licensing Manager. Tel: +44 (0)20 8996 7070 Email: copyright@bsigroup.com