

BS EN 1363-1:2012



BSI Standards Publication

<http://www.china-gauges.com/>

Fire resistance tests

Part 1: General Requirements

NO COPYING WITHOUT BSI PERMISSION EXCEPT AS PERMITTED BY COPYRIGHT LAW

raising standards worldwide™



National foreword

This British Standard is the UK implementation of EN 1363-1:2012. It supersedes BS EN 1363-1:1999, which is withdrawn.

The UK participation in its preparation was entrusted to Technical Committee FSH/22/-/7, Non loadbearing separating elements.

A list of organizations represented on this committee can be obtained on request to its secretary.

This publication does not purport to include all the necessary provisions of a contract. Users are responsible for its correct application.

© The British Standards Institution 2012
Published by BSI Standards Limited 2012

ISBN 978 0 580 76353 3

ICS 13.220.50

Compliance with a British Standard cannot confer immunity from legal obligations.

This British Standard was published under the authority of the Standards Policy and Strategy Committee on 31 August 2012.

Amendments issued since publication

Date	Text affected
------	---------------

EUROPEAN STANDARD

EN 1363-1

NORME EUROPÉENNE

EUROPÄISCHE NORM

July 2012

ICS 13.220.50

Supersedes EN 1363-1:1999

English Version

Fire resistance tests - Part 1: General Requirements

Essais de résistance au feu - Partie 1: Exigences générales

Feuerwiderstandsprüfungen - Teil 1: Allgemeine Anforderungen

This European Standard was approved by CEN on 9 June 2012.

CEN members are bound to comply with the CEN/CENELEC Internal Regulations which stipulate the conditions for giving this European Standard the status of a national standard without any alteration. Up-to-date lists and bibliographical references concerning such national standards may be obtained on application to the CEN-CENELEC Management Centre or to any CEN member.

This European Standard exists in three official versions (English, French, German). A version in any other language made by translation under the responsibility of a CEN member into its own language and notified to the CEN-CENELEC Management Centre has the same status as the official versions.

CEN members are the national standards bodies of Austria, Belgium, Bulgaria, Croatia, Cyprus, Czech Republic, Denmark, Estonia, Finland, Former Yugoslav Republic of Macedonia, France, Germany, Greece, Hungary, Iceland, Ireland, Italy, Latvia, Lithuania, Luxembourg, Malta, Netherlands, Norway, Poland, Portugal, Romania, Slovakia, Slovenia, Spain, Sweden, Switzerland, Turkey and United Kingdom.



EUROPEAN COMMITTEE FOR STANDARDIZATION
COMITÉ EUROPÉEN DE NORMALISATION
EUROPÄISCHES KOMITEE FÜR NORMUNG

Management Centre: Avenue Marnix 17, B-1000 Brussels

Contents

	Page
Foreword.....	5
Introduction	6
1 Scope	7
2 Normative references	7
3 Terms, definitions, symbols and designations	8
3.1 Terms and definitions	8
3.2 Symbols and designations	10
4 Test equipment	10
4.1 General.....	10
4.2 Furnace	11
4.3 Loading equipment.....	11
4.4 Test frames.....	11
4.5 Instrumentation.....	12
4.5.1 Temperature	12
4.5.2 Pressure.....	13
4.5.3 Load	13
4.5.4 Deflection.....	13
4.5.5 Integrity.....	13
4.6 Precision of measuring equipment.....	14
5 Test conditions	14
5.1 Furnace temperature	14
5.1.1 Heating curve	14
5.1.2 Tolerances	14
5.2 Furnace pressure.....	15
5.2.1 General.....	15
5.2.2 Establishing the neutral pressure plane	16
5.3 Furnace atmosphere	16
5.4 Loading	16
5.5 Restraint/boundary conditions.....	16
5.6 Ambient temperature conditions	17
5.7 Deviation from required test conditions	17
6 Test specimen(s).....	17
6.1 Size	17
6.2 Number	17
6.2.1 Separating elements.....	17
6.2.2 Non-separating elements	17
6.3 Design	17
6.4 Construction.....	18
6.5 Verification	18
7 Installation of test specimen	18
7.1 General.....	18
7.2 Supporting constructions	18
7.2.1 General.....	18
7.2.2 Standard supporting constructions.....	19
7.2.3 Non-standard supporting constructions.....	21
8 Conditioning.....	21
8.1 Test specimen	21

8.2	Supporting constructions	21
9	Application of instrumentation	21
9.1	Thermocouples	21
9.1.1	Furnace thermocouples (plate thermometers).....	21
9.1.2	Unexposed surface thermocouples	22
9.1.3	Internal thermocouples.....	23
9.2	Pressure	23
9.2.1	General	23
9.2.2	Furnaces for vertical elements	23
9.2.3	Furnaces for horizontal elements.....	23
9.3	Deflection	23
10	Test procedure.....	24
10.1	Restraint application.....	24
10.2	Load application.....	24
10.3	Commencement of test.....	24
10.4	Measurements and observations	24
10.4.1	General	24
10.4.2	Temperatures	24
10.4.3	Furnace pressure	25
10.4.4	Deflection	25
10.4.5	Integrity	25
10.4.6	Load and restraints	26
10.4.7	General behaviour.....	26
10.5	Termination of test	26
11	Performance criteria.....	27
11.1	Loadbearing capacity.....	27
11.2	Integrity	27
11.3	Insulation.....	28
11.4	Consequential effects of failing certain performance criteria	28
11.4.1	Insulation and integrity versus loadbearing capacity	28
11.4.2	Insulation versus integrity.....	28
12	Test report.....	28
12.1	Test report.....	28
12.2	Expression of test results in the test report.....	30
Annex A	(informative) Field of application of test results	39
A.1	General	39
A.2	Field of direct application.....	39
A.3	Extended application	39
Annex B	(informative) The role of supporting constructions.....	40
B.1	General	40
B.2	Standard supporting constructions	40
B.3	Non-standard supporting constructions	40
Annex C	(informative) General information on thermocouples	42
C.1	Furnace thermocouples (plate thermometers).....	42
C.1.1	Maintenance.....	42
C.1.2	Positioning	42
C.2	Internal thermocouples.....	42
C.2.1	General	42
C.2.2	Specification	42
C.2.3	Fixing methods and positioning	42
C.3	Unexposed face thermocouples	43
C.3.1	General	43
C.3.2	Positioning	43
C.3.3	Fixing to specific materials	44
Annex D	(informative) Guidance on the basis for selection of the test load	46

D.1	General.....	46
D.2	Options for selecting the test load.....	46
Annex E (informative) Boundary and support conditions		47
Annex F (informative) Guidance on conditioning		48
F.1	General.....	48
F.2	Guidance on procedures for conditioning	48
F.3	Guidance on measurement techniques	49
F.3.1	Direct reading moisture meter.....	49
F.3.2	Oven drying techniques.....	49
Annex G (informative) Guidance on deflection measurements of vertical separating elements using a fixed datum		50
G.1	General.....	50
G.2	Apparatus	50
G.3	Procedure	50
G.4	Reporting	51
Bibliography		52

<http://www.china-gauges.com/>

Foreword

This document (EN 1363-1:2012) has been prepared by Technical Committee CEN/TC 127 "Fire safety in buildings", the secretariat of which is held by BSI.

This European Standard shall be given the status of a national standard, either by publication of an identical text or by endorsement, at the latest by January 2013, and conflicting national standards shall be withdrawn at the latest by January 2013.

Attention is drawn to the possibility that some of the elements of this document may be the subject of patent rights. CEN [and/or CENELEC] shall not be held responsible for identifying any or all such patent rights.

This document supersedes EN 1363-1:1999.

The main changes compared to EN 1363-1:1999 are:

- a) a tolerance is specified for the thickness of the thermocouple wire in the furnace thermocouple;
- b) a small variation to the layout of the unexposed surface thermocouples;
- c) a tolerance to the maximum pressure is specified;
- d) a redefinition of standard supporting constructions;
- e) a change to the required distance of thermocouples to a discontinuity from 15 mm into 20 mm;
- f) a redefinition of the commencement of the fire test;
- g) a redefinition for the load bearing capacity criterion;
- h) specifications for the short form test report are removed.

This document has been prepared under a mandate given to CEN by the European Commission and the European Free Trade Association.

This European Standard is technically related to ISO 834-1 prepared by ISO/TC92/SC2 "Fire resistance tests".

EN 1363, *Fire resistance tests*, consists of the following parts:

- *Part 1: General requirements* (this European Standard);
- *Part 2: Alternative and additional procedures*;
- *Part 3: Verification of furnace performance* (published as an ENV).

According to the CEN/CENELEC Internal Regulations, the national standards organisations of the following countries are bound to implement this European Standard: Austria, Belgium, Bulgaria, Croatia, Cyprus, Czech Republic, Denmark, Estonia, Finland, Former Yugoslav Republic of Macedonia, France, Germany, Greece, Hungary, Iceland, Ireland, Italy, Latvia, Lithuania, Luxembourg, Malta, Netherlands, Norway, Poland, Portugal, Romania, Slovakia, Slovenia, Spain, Sweden, Switzerland, Turkey and the United Kingdom.

Introduction

The objective of determining fire resistance is to assess the behaviour of a specimen of an element of building construction when subjected to defined heating and pressure conditions. The method provides a means of quantifying the ability of an element to withstand exposure to high temperatures. This is done by setting criteria against which the loadbearing capacity, the fire containment (integrity) and the thermal transmittance (insulation) functions amongst other characteristics can be evaluated.

A representative sample of the element is exposed to a specified regime of heating and the performance of the test specimen is monitored on the basis of criteria described in the standard. Fire resistance of the test element is expressed as the time for which the appropriate criteria have been satisfied. The times so obtained are a measure of the adequacy of the construction in a fire; but they have no direct relationship with the duration time of a real fire.

Caution

The attention of all persons concerned with managing and carrying out fire resistance testing is drawn to the fact that fire testing might be hazardous and that there is a possibility that toxic and/or harmful smoke and gases will be emitted during the test. Mechanical and operational hazards might also arise during the construction of the test elements or structures, their testing and disposal of test residues.

An assessment of all potential hazards and risks to health needs to be made and safety precautions need to be identified and provided. Written safety instructions will be issued. Appropriate training will be given to relevant personnel. Laboratory personnel will ensure that they follow written safety instructions at all times.

Uncertainty of measurement of fire resistance

There are many factors which can affect the result of a fire resistance test. Those concerned with the variability of the specimen including its materials, manufacture and installation are not related to the uncertainty of measurement. Of the remainder, some, such as the different thermal dose provided by different furnaces, are much more significant than others such as the accuracy of calibration of the data logging system.

Because of the very labour intensive nature of the test, many of the factors that have a bearing on the result are operator-dependent. The training, experience and attitude of the operator is thus crucial to eliminate such variables which can significantly affect the degree of uncertainty of measurement. Unfortunately, it is not possible to numerically quantify these factors and therefore any attempt to determine uncertainty of measurement that does not take into account operator-dependent variables is of limited value.

1 Scope

This European Standard establishes the general principles for determining the fire resistance of various elements of construction when subjected to standard fire exposure conditions. Alternative and additional procedures to meet special requirements are given in EN 1363-2.

The principle that has been embodied within all European Standards relating to fire resistance testing is that where aspects and procedures of testing are common to all specific test methods e.g. the temperature/time curve, then they are specified in this test method. Where a general principle is common to many specific test methods but the details vary according to the element being tested (e.g. the measurement of unexposed face temperature), then the principle is given in this document but the details are given in the specific test method. Where certain aspects of testing are unique to a particular specific test method (e.g. the air leakage test for fire dampers), then no details are included in this document.

The test results obtained might be directly applicable to other similar elements, or variations of the element tested. The extent to which this application is permitted depends upon the field of direct application of the test result. This is restricted by the provision of rules which limit the variation from the tested specimen without further evaluation. The rules for determining the permitted variations are given in each specific test method.

Variations outside those permitted by direct application are covered under extended application of test results. This results from an in-depth review of the design and performance of a particular product in test(s) by a recognised authority. Further consideration on direct and extended application is given in Annex A.

The duration for which the tested element, as modified by its direct or extended field of application, satisfies specific criteria will permit subsequent classification.

All values given in this Standard are nominal unless otherwise specified.

2 Normative references

The following documents, in whole or in part, are normatively referenced in this document and are indispensable for its application. For dated references, only the edition cited applies. For undated references, the latest edition of the referenced document (including any amendments) applies.

EN 520, *Gypsum plasterboards — Definitions, requirements and test methods*

EN 1363-2, *Fire resistance tests — Part 2: Alternative and additional procedures*

EN 13501-1, *Fire classification of construction products and building elements — Part 1: Classification using data from reaction to fire tests*

EN ISO 13943:2010, *Fire safety — Vocabulary (ISO 13943:2008)*

EN 60584-1, *Thermocouples — Part 1: Reference tables (IEC 60584-1)*

EN 60584-2, *Thermocouples — Part 2: Tolerances (IEC 60584-2)*

3 Terms, definitions, symbols and designations

3.1 Terms and definitions

For the purposes of document, the terms and definitions given in EN ISO 13943:2010 and the following apply.

3.1.1

actual material properties

properties of a material determined from representative samples taken from the test specimen for the fire test according to the requirements of the specific product standard

3.1.2

characteristic material properties

properties of a material which are specified for a grade of material which may be used for design purposes

3.1.3

associated construction

form of construction required to test some types of test specimen

EXAMPLE The aerated concrete slabs on top of a beam.

3.1.4

deflection

movement associated with structural and or thermal actions

3.1.5

discontinuity

interruption in the construction associated with a change in material or a joint

Note 1 to entry: Examples of discontinuities are the joint between two adjacent boards in a partition, or the joint between one type of construction and another, such as the joint between a partition and a doorset or the joint between a partition and a glazed area within it.

3.1.6

element of building construction

defined construction component, such as a wall, partition, doorset, floor, roof, beam or column

3.1.7

exposed face

side of the test construction that is exposed to the heating conditions of the test

3.1.8

glowing

emittance of light without flaming associated with combustion of a material

3.1.9

insulation

ability of a test specimen of a separating element of building construction, when exposed to fire on one side, to restrict the temperature rise of the unexposed face to below specified levels

3.1.10

integrity

ability of a test specimen of a separating element of building construction, when exposed to fire on one side, to prevent the passage of flames and hot gases through and to prevent the occurrence of flames on the unexposed side

3.1.11

loadbearing capacity

ability of a test specimen of a loadbearing element to support its test load, where appropriate, without exceeding specified criteria with respect to both the extent of, and rate of, deflection

3.1.12

loadbearing element

element that is intended for use in supporting an external load in a building and maintaining this support in the event of a fire

3.1.13

neutral pressure plane

elevation at which the pressure is equal inside and outside of the furnace

3.1.14

notional floor level

assumed floor level relative to the position of the building element in service

3.1.15

restraint

constraint to expansion or rotation (induced by thermal and/or mechanical actions) afforded by the conditions at the ends, edges or supports of a test specimen

EXAMPLE Examples of different types of restraint are: longitudinal, rotational and lateral.

3.1.16

separating element

element that is intended for use in maintaining separation between two adjacent areas of a building in the event of a fire

3.1.17

supporting construction

construction that may be required for the testing of some building elements into which the test specimen is assembled

Note 1 to entry: For example, the wall into which a doorset is fitted, See Annex B

3.1.18

sustained flaming

continuous flaming for a period of time greater than 10 s

3.1.19

test construction

complete assembly of the test specimen together with its supporting construction

3.1.20

test frame

frame containing the test construction for the purpose of mounting onto the furnace

3.1.21

test load

load applied to the test specimen

3.1.22

test specimen

element (or part) of building construction provided for the purpose of determining either its fire resistance or its contribution to the fire resistance of another building element

3.1.23

discrete area(s)

portion(s) of the total surface of the test specimen, which may be expected to have different fire insulation performance

3.2 Symbols and designations

The symbols and designations listed below define those used in this document.

Symbol	Unit	Description
A	°C min	the area under the average furnace temperature/time curve
A_s	°C min	the area under the standard temperature/time curve
C	mm	axial contraction measured from the start of heating
d	mm	the distance from the extreme fibre of the design compression zone to the extreme fibre of the design tensile zone of the structural section of a flexural test specimen
D	mm	the deflection measured from the commencement of heating
h	mm	the initial height of the loaded vertical test specimen
L	mm	the length of the span of the test specimen
t	min	the time from the commencement of heating
T	°C	the temperature within the test furnace
ΔT	K	the temperature difference or the temperature rise

4 Test equipment

4.1 General

Equipment used to carry out the test consists essentially of the following:

- a specially designed furnace to subject the test specimen to the test conditions;
- control equipment to enable the temperature of the furnace to be controlled as required in 5.1;
- equipment to control and monitor the pressure of the hot gases within the furnace as required in 5.2;
- a frame in which the test construction can be erected and which can be positioned in conjunction with the furnace so that appropriate heating, pressure and support conditions can be developed;
- arrangement for loading and restraint of the test specimen as appropriate, including control and monitoring of load;
- equipment for measuring temperature in the furnace and on the unexposed face of the test specimen, and where needed within the test specimen;
- equipment for measuring the deflection of the test specimen;
- equipment for evaluating integrity and for establishing compliance with the performance criteria described in Clause 11;
- equipment for establishing the elapsed time;
- equipment for measuring the oxygen concentration of furnace gases.

4.2 Furnace

The test furnace shall be designed to employ liquid or gaseous fuels and shall be capable of:

- a) heating of vertical or horizontal separating elements on one face, or
- b) heating of columns on all sides, or
- c) heating of walls on more than one side, or
- d) heating of beams on three or four sides, as appropriate.

Other special furnaces may be required for specific requirements.

The furnace linings shall consist of materials with densities less than 1 000 kg/m³. Such lining materials shall have a minimum thickness of 50 mm and shall constitute at least 70 % of the internally exposed surface of the furnace.

The furnace shall be capable of providing the standard fire exposure conditions with respect to thermal exposure and pressure.

Furnaces may be designed so that assemblies of more than one element can be tested simultaneously, provided that all the requirements for each individual element can be complied with.

4.3 Loading equipment

The loading equipment shall be capable of subjecting test specimens to the level of loading determined in accordance with 5.4. The load may be applied hydraulically, mechanically or by the use of weights.

The loading equipment shall be able to simulate conditions of uniform loading, point loading, concentric loading, axial loading or eccentric loading as appropriate for the test construction. The loading equipment shall be capable of maintaining the test load at a constant value ($\pm 5\%$ of the required value) without changing its distribution and following the maximum deflection and the rate of deflection of the test specimen until failure of loadbearing capacity occurs as defined in 11.3 or for the duration of the test, whichever occurs sooner.

The loading equipment shall not significantly influence the heat transfer through the specimen nor impede the use of the thermocouple insulating pads. It shall not interfere with the measurement of surface temperature and/or deflection and shall permit general observation of the unexposed face. The total area of the contact points between the loading equipment and the test specimen surface shall not exceed 10 % of the total area of the surface of a horizontal test specimen.

4.4 Test frames

Special test frames or other means shall be employed to reproduce the boundary and support conditions appropriate for the test constructions as required by 5.5. Different types of test constructions will require test frames of differing stiffness. The performance of the test frames shall be evaluated by applying an expansion force within the frame at mid-width between two opposite members and measuring the increase in the internal dimension. The increase shall not exceed 5 mm with an applied force of 25 kN. This evaluation shall be conducted in both directions of the frame.

Where test frames are to meet different requirements, these other requirements are given in the specific test method.

4.5 Instrumentation

4.5.1 Temperature

4.5.1.1 Furnace thermocouples

The furnace thermocouples shall be plate thermometers comprised of an assembly of a folded nickel alloy plate, a thermocouple fixed to it and insulation material.

The folded metal plate shall be constructed from a strip of austenitic nickel based superalloy for high temperature oxidation resistance, (150 ± 1) mm long by (100 ± 1) mm wide by $(0,7 \pm 0,1)$ mm, folded to the design as shown in Figure 1.

The measuring junction shall consist of nickel-chromium/nickel aluminium (type K) wire as defined in EN 60584-1, contained within mineral insulation in a heat resisting steel alloy sheath of nominal diameter range of 1 mm to 3 mm, the hot junctions being electrically insulated from the sheath. The thermocouple hot junction shall be fixed to the geometric centre of the plate in the position shown in Figure 1 by a small strip made from the same material as the plate. The strip can be welded to the plate or may be screwed to it to facilitate replacement of the thermocouple. The strip shall be approximately 18 mm by 6 mm if it is spot welded to the plate and nominally 25 mm by 6 mm if it is to be screwed to the plate. The screw shall be 2 mm in diameter.

The assembly of plate and thermocouple shall be fitted with a pad of inorganic insulation material nominally (97 ± 1) mm by (97 ± 1) mm by (10 ± 1) mm thick and with a density of (280 ± 30) kg/m³.

Before the plate thermometers are first used, the folded plate part shall be aged by immersing it in a pre-heated oven at 1 000 °C for 1 h, or exposing it in a fire resistance furnace for 90 min during a test carried out following the standard temperature/time curve given in 5.1.1.

Where a plate thermometer is used more than once, a log of its use shall be maintained, indicating for each use the checks made and duration of use. The thermocouple and the insulation pad shall be replaced after 50 h exposure in the furnace.

4.5.1.2 Unexposed surface thermocouples

The temperature of the unexposed surface of the test specimen shall be measured by means of disc thermocouples of the type shown in Figure 2. In order to provide a good thermal contact, type K thermocouple wires, as defined in EN 60584-1, 0,5 mm in diameter (with tolerances as defined in EN 60584-2) shall be soldered to a 0,2 mm thick by 12 mm diameter copper disc. It is also permitted to use thermocouples whose wires have been twisted together and then soldered to the copper disc.

Each thermocouple shall be covered with a (30 ± 2) mm x (30 ± 2) mm x $(2 \pm 0,5)$ mm thick insulating pad, silicate-fibre based and classified as A1 or A2 according EN 13501-1. The pad material shall have a density of (900 ± 100) kg/m³, unless specified otherwise in specific test standards. The insulation pads shall be cut to accommodate the thermocouple wires. If the thermocouple wires are soldered separately to the disc as shown in Figure 2, the slots may originate from opposite corners of the pad or from mid way along opposite edges. The measuring and recording equipment shall be capable of operating within the limits specified in 4.6.

In the case of non-planar surface of the test specimen, the disc and/or pad shall be deformed to follow the main surface profile. If there is difficulty in fixing the standard pad, the size of the pad may be reduced on two parallel sides subject to covering the disc.

4.5.1.3 Roving thermocouples

One or more roving thermocouples of the design shown in Figure 3 shall be available to measure the unexposed surface temperature during a test at positions where higher temperatures are suspected. The measuring junction of the thermocouple shall consist of type K thermocouple wires as defined in EN 60584-1, 1,0 mm in diameter soldered to a 12 mm diameter, 0,5 mm thick copper disc. The thermocouple assembly

shall be provided with a handle so that it can be applied over any point on the unexposed surface of the test specimen.

4.5.1.4 Internal thermocouples

If information concerning the internal temperature of a test specimen or particular component is required, it shall be obtained by means of thermocouples having characteristics appropriate to the range of temperatures to be measured, as well as suitable to the type of materials in the test specimen. A specification for the thermocouples for measurement of internal temperature is given in Annex B.

4.5.1.5 Ambient temperature thermocouple

A thermocouple shall be used to indicate the ambient temperature within the laboratory in the vicinity of the test specimen both prior to and during the test period. The thermocouple shall be nominally 3 mm diameter, mineral insulated, stainless steel sheathed type K thermocouple as defined in EN 60584-1 with tolerances in accordance with EN 60584-2. The measuring junction shall be protected from radiated heat and draughts with a device as shown in Figure 6.

4.5.2 Pressure

The pressure in the furnace shall be measured by means of one of the designs of sensors described in Figure 4. The measuring and recording equipment shall be capable of operating within the limits specified in 4.6.

Data measured at each measuring interval shall be used in the analysis of the test specimen's performance. If the data is presented as fixed or floating average values, the methodology for processing the data presented shall be clearly explained in the test report.

4.5.3 Load

When using weights, no further measurement of load in a test is needed. The loads applied by hydraulic loading systems shall be measured by means of a load cell or other relevant equipment having the same accuracy or by monitoring the hydraulic pressure at an appropriate point. The measuring and recording equipment shall be capable of operating within the limits specified in 4.6.

4.5.4 Deflection

Deflection measurements can be made by using equipment employing mechanical, optical or electrical techniques. Where such equipment is used in relation to performance criteria, e.g. for measurements of deflection or contraction, it shall be capable of operating at a frequency of at least one reading per minute. All necessary precautions shall be taken to prevent any drift in the sensor readings due to heating. Details of precision of measuring equipment are given in 4.6.

4.5.5 Integrity

4.5.5.1 Cotton pad

Unless specified otherwise in the standards for specific elements, the cotton pad employed in the measurement of integrity shall consist of 100 % new, untreated, undyed and soft cotton fibres which shall weigh between 3 g – 4 g per 100 x 100 x 20 mm. It shall be conditioned prior to use by drying in an oven at (100 ± 5) °C for at least 30 min. After drying it may be stored in a desiccator or in an airtight container for up to one week before oven drying again as described above. For use it shall be mounted in a wire frame with sizes of either $(100 \pm 5) \times (100 \pm 5) \times (20 \pm 1)$ mm or $(30 \pm 2) \times (30 \pm 2) \times (20 \pm 1)$ mm, as shown in Figure 5, provided with a handle of suitable length. The cotton pad with nominal sizes 30 x 30 x 20 mm shall only be used when required by the specific test method.

4.5.5.2 Gap gauges

Two types of gap gauge, as shown in Figure 6, shall be available for the measurement of integrity. They shall be made of cylindrical steel rod of $(6 \pm 0,1)$ mm and $(25 \pm 0,2)$ mm diameter. They shall be provided with insulated handles of suitable length.

4.6 Precision of measuring equipment

For conducting fire resistance tests, the measuring equipment shall meet the following levels of precision:

- a) temperature measurement:
 - 1) furnace: ± 15 K
 - 2) ambient and unexposed face: ± 4 K
 - 3) other: ± 10 K
- b) pressure measurement: $\pm 2,0$ Pa
- c) load level: $\pm 2,5\%$ of test load
- d) axial contraction or expansion measurement: $\pm 0,5$ mm
- e) other deflection measurements: ± 2 mm

5 Test conditions

5.1 Furnace temperature

5.1.1 Heating curve

The average temperature of the furnace as derived from the thermocouples specified in 4.5.1.1 shall be monitored and controlled such that it follows the relationship:

$$T = 345 \log_{10}(8t + 1) + 20 \quad (\text{See Figure 7})$$

where

T is the average furnace temperature, in degree Celsius;

t is the time, in minutes.

5.1.2 Tolerances

The percentage deviation (d_e) in the area of the curve of the average temperature recorded by the specified furnace thermocouples versus time from the area of the standard temperature/time curve shall be within:

- a) 15 % for $5 < t \leq 10$;
- b) $(15 - 0,5(t-10))$ % for $10 < t \leq 30$;
- c) $(5 - 0,083(t-30))$ % for $30 < t \leq 60$;

d) 2,5 % for $t > 60$;

where

$$d_e = \frac{A - A_s}{A_s} \times 100$$

where

d_e is the percentage deviation;

A is the area under the actual furnace temperature/time curve;

A_s is the area under the standard temperature/time curve;

t is the time in minutes

All areas shall be computed by the same method, i.e. by the summation of areas at intervals not exceeding 1 min and shall be calculated from time zero.

At any time after the first 10 min of the test, the temperature recorded by any thermocouple in the furnace shall not differ from the corresponding temperature of the standard temperature/time curve by more than 100 K.

For test specimens which burn rapidly, a deviation in excess of 100 K above the specified temperature/time curve may be exceeded for a period not in excess of 10 min, provided that such an excess deviation is clearly identified as being associated with the sudden ignition of significant quantities of combustible materials increasing the gas temperature in the furnace.

NOTE While no tolerances are given for compliance with the temperature/time curve during the first 5 min of the test, it is expected that the laboratory will attempt to follow the prescribed relationship as closely as possible during that period, so that the difference between the integrals of the prescribed and achieved curves is kept to a minimum at any period during the test.

5.2 Furnace pressure

5.2.1 General

The pressure distribution over the height of a furnace is mainly influenced by the natural buoyancy effect of the gases. For the purpose of controlling the pressure, it can be assumed that the pressure gradient will be approximately 8,5 Pa per metre height of furnace.

The pressure measuring system shall be such that it disregards rapid fluctuations in pressure (e.g. with cycles of 1 s or less) associated with turbulence etc. The furnace pressure shall be established relative to the pressure outside the furnace at the same height.

The furnace pressure shall be monitored and controlled. 5 min after the commencement of the test the furnace pressure shall be ± 5 Pa of the nominal pressure specified for the particular element under test; from 10 min onwards it shall be ± 3 Pa of the nominal pressure specified for the particular element under test.

For a test specimen which burns rapidly, a deviation in excess of the above mentioned tolerances on the specified furnace pressure may be exceeded for a period of maximum 5 min, provided that such an excess deviation is clearly identified as being associated with the sudden ignition of significant quantities of combustible materials increasing the pressure in the furnace.

5.2.2 Establishing the neutral pressure plane

5.2.2.1 General

Unless specified otherwise in specific test standards, the furnace shall be operated so that the neutral pressure plane (a pressure of zero) is established 500 mm above notional floor level. Where a pressure greater than 20 Pa is expected at the top of the vertical test specimen, the nominal pressure of the furnace shall not exceed 20 Pa. This requirement may result in adjustment of the height of the neutral pressure plane.

5.2.2.2 Multiple vertical separating elements

For those test methods where several specimens can be accommodated over the height of the furnace and where a fixed nominal pressure is specified for the element being tested, the fixed nominal pressure shall apply to the lowest test specimen and the limit of 20 Pa at the top of the specimen does not apply.

5.2.2.3 Horizontal separating elements

Unless specified otherwise in specific test standards, the furnace shall be operated such that the pressure on the underside of the test construction is determined in relation to the element's height relative to notional floor level. Irrespective of this, the nominal pressure on the underside of the test specimen shall not exceed 20 Pa. The pressure condition shall be established 100 mm below the underside of the separating element.

5.2.2.4 Non-separating elements

Non-separating elements shall be subjected to similar pressure conditions as appropriate to separating elements with the same orientation, i.e. beams as per floors, columns as per walls.

5.3 Furnace atmosphere

The fuel/air ratio to the burners and the introduction of any secondary air shall be set to give a minimum oxygen content of furnace atmosphere of 4 % when testing specimens with no combustible content. This fuel/air ratio setting of the burners, including any setting for introducing secondary air, shall not be changed after the last verification of furnace performance.

NOTE ENV 1363-3 gives a suitable procedure for verification of furnace performance.

5.4 Loading

The sponsor shall provide the basis for the test load, including any calculation, if the test load is based on material properties. The sponsor shall also indicate the relationship between the test load and the load applied in service (if known). The laboratory shall verify, as far as possible, the material properties used by the sponsor in the calculation of the test load.

Further guidance on the basis for determining the test load is given in Annex D.

5.5 Restraint/boundary conditions

The test specimen, or test construction if appropriate, shall be mounted in a special test frame designed to reproduce the required or the design boundary and support conditions. The type of test frame and the performance required from it will vary according to the element being tested.

General guidance on boundary and supporting conditions is given in Annex E. The requirements appropriate to each element are given in the specific test methods.

5.6 Ambient temperature conditions

The ambient air temperature shall be in the range 10 °C to 40 °C at the commencement of the test. This temperature shall be monitored at a distance of between 1 m and 3 m horizontally away from the unexposed face using the device as shown in Figure 8, under conditions such that the sensor is not affected by thermal radiation from the test construction and/or furnace.

During the test, the temperature in the laboratory shall not decrease by more than 10 K or increase by more than 20 K for all insulated separating elements while they continue to satisfy the insulation criterion.

5.7 Deviation from required test conditions

Should the conditions of furnace temperature, furnace pressure or ambient temperature which are achieved during the test represent a more severe exposure to the test specimen, the test is still to be considered valid.

6 Test specimen(s)

6.1 Size

The test specimen shall be normally full size. When the specimen cannot be tested full size, the specimen size shall be in accordance with the specific test method.

6.2 Number

6.2.1 Separating elements

For separating elements that are only required to be fire resistant from one side, one specimen shall be tested with the exposed face being the side that will be subject to fire attack.

For separating elements that are required to be fire resistant from both sides, two specimens shall be tested separately (one from each direction) unless the separating element is fully symmetrical and the required fire exposure conditions for both directions are identical.

For separating elements that are required to be fire resistant from both sides, the appropriate test method shall define the rule on which basis a "weakest" side can be determined. The results of specimen tested with fire attack from the "weakest" side cover the fire resistance of the element with fire exposure also from the opposite direction.

If testing is carried out from one side only, whether due to the fact that the separating element is symmetrical or because it is only required to resist fire from one side, this shall be stated in the test report.

Different boundary conditions may require additional test specimens.

6.2.2 Non-separating elements

For all non-separating elements only one specimen is required.

6.3 Design

Materials used in the construction of the test specimen shall be representative of the use of the element in practice. It is important to include appropriate surface finishes and fittings which are an essential part of the specimen and which may influence its behaviour in the test. No variation in construction (e.g. different jointing systems) shall be included in a single test specimen. Any modifications made to accommodate the installation of a test specimen within the prescribed test frame shall be such as to have no significant influence on the behaviour of the test specimen and shall be fully described in the test report.

6.4 Construction

The method of construction including the tolerances and the erection shall be representative of the use of the element in practice. The standard of workmanship shall be as normally provided in buildings and shall include the same way of accessing the test specimen, e.g. suspended ceilings which are accessed normally only from below.

The sponsor shall be responsible for ensuring that the quality of construction of the test specimen is representative of the product in practice.

The laboratory shall monitor the erection of the test specimen in order to be able to include details of the methodology and workmanship in the test report.

6.5 Verification

The sponsor shall provide a description of all constructional details, drawings and schedule of major components and their manufacturer/supplier, as well as an assembly procedure to the test laboratory, prior to the test. This shall be provided sufficiently in advance of the test to enable the laboratory to verify the conformity of the test specimen with the information provided. As far as possible, any area of discrepancy shall be resolved prior to starting the test. In order to ensure that the description of the test specimen, and in particular its construction, is in conformity with the test specimen, the laboratory shall either oversee the fabrication of the test specimen or request an additional test specimen. Where appropriate, the actual material properties shall be determined.

On occasion, it may not be possible to verify the conformity of all aspects of the construction of the test specimen prior to the test and adequate evidence may not be available after test. When it is necessary to rely on information provided by the sponsor this fact shall be clearly stated in the test report. The laboratory shall nevertheless ensure that it fully appreciates the design of the test specimen and shall be confident that it is able to accurately record the constructional details in the test report. Additional procedures for specimen verification are found in the test methods for specific products.

The process of verification may be carried out by a third party. However, the responsibility remains with the laboratory.

7 Installation of test specimen

7.1 General

The test specimen shall be installed as far as possible in a manner representative of its use in practice.

Detailed procedures for the installation of different types of test specimens are given in the relevant test methods.

7.2 Supporting constructions

7.2.1 General

Depending on the type of test specimen being evaluated, it may be necessary to mount it in a supporting construction.

7.2.2 Standard supporting constructions

7.2.2.1 High density rigid construction

This kind of construction consists either of blockwork, masonry or homogenous concrete wall with an overall density $\geq 850 \text{ kg/m}^3$ and a thickness appropriate for the expected fire resistance period.

7.2.2.2 Low density rigid construction

This kind of construction consists of an aerated concrete blockwork with an overall density of $(650 \pm 200) \text{ kg/m}^3$ and a thickness appropriate for the expected fire resistance period.

7.2.2.3 Mortar

For blockwork (incorporating aerated concrete) or masonry wall supporting constructions given in 7.2.2.1 and 7.2.2.2, the individual masonry units shall be bonded together with a mortar appropriate for the expected fire resistance period.

7.2.2.4 Flexible construction

This is a lightweight plasterboard faced steel stud partition, constructed in accordance with conditions given below and Table 1.

a) Components:

- 1) Head/floor track: Rolled steel U- track, 0,5 mm to 1,5 mm thick;
- 2) Studs: Rolled C studs, 0,5 mm to 1,5 mm thick;
- 3) Linings: Paper faced, gypsum plasterboard type F (see EN 520). The number of layers and thickness to be fixed to each side as specified in Table 1;
- 4) Fixings:
 - i) self drilling/self tapping screws;
 - ii) 20 mm to 36 mm long for the first layer of 12,5 mm or 15 mm thick boards;
 - iii) 35 mm to 46 mm long for the second layer of 12,5 mm or 15 mm thick boards;
- 5) Jointing compound: Gypsum plaster;
- 6) Insulation: As specified in Table 1, unless specified otherwise in specific test methods;

b) Construction

- 1) Restraint: The wall shall only be restrained at the top and bottom edges;
- 2) Fixing centres: Head and floor track to furnace test frame, centre to centre distance of 600 mm;
- 3) Edges: Vertical edges not to be fixed to test frame;
- 4) Stud centres: Between 400 mm and 625 mm (depending on the size and position of the opening for the test specimen). These centres do not apply within the 200 mm separation between a specimen and the edge of the furnace;
- 5) Stud fixing: Friction only;

- 6) Expansion allowance for studs: maximum 3,5 mm / meter height;

NOTE 1 This is not a design allowance for studs.

- 7) Fixing centers Plaster boards to framework at maximum 300 mm around the periphery and in the field in each layer;
- 8) Location of vertical joints: To be staggered between layers of plasterboard, in multi-layer partitions, and staggered on each side of the studs for single-layer partitions;
- 9) Location of horizontal joints (if applicable): To be coincident for one layer systems at nominal 2 400 mm high; to be staggered between layers of plasterboard, in multi-layer partitions at nominally 600 mm high and outer layer at nominally 2 400 mm high;
- 10) Filling of joints: Outer layer only to be filled with gypsum plaster jointing compound.

If the boards used in the flexible construction are not full height, a horizontal joint shall be used at the locations stated above. The horizontal joints will need to be backed up to prevent a premature failure. A suitable method for this is to place a 100 mm wide fixing strap made from steel 0,5 mm thick behind the outer layer of board at the location of the joint. The fixing strap shall be located by drywall screws fixed through the outer layer of board at 300 mm centres. For all systems, the fixing strap is only required behind the outer layer of boards.

Table 1 — Specifications for flexible constructions

Intended fire resistance	Nominal steel stud depth [mm]			Gypsum boards type F, EN 520		Insulation: mineral wool	
	Group A	Group B	Group C	number of layers at each side	thickness of boards [mm]	thickness [mm]	density [kg/m ³]
EI 30	44 - 55	56 - 75	76 - 100	1	12,5	40 - 50	30 - 60
EI 60	44 - 55	56 - 75	76 - 100	2	12,5	40 - 50	30 - 60
EI 90	44 - 55	56 - 75	76 - 100	2	12,5	40 - 50	85 - 115
EI 120	62 - 70	71 - 75	76 - 100	2	15	60 - 70	85 - 115

NOTE 2 Flexible constructions with fire resistance 180 and 240 are not defined as standard supporting constructions because the information available is inconsistent.

NOTE 3 The minimum nominal steel studs mentioned represent the varying depth used in the European construction market.

NOTE 4 The flexible constructions contain insulation in the void because this will increase thermal deformation which is more onerous.

A test undertaken using a certain stud depth as defined in Group A, B or C is applicable to constructions using a stud depth in the range as defined for the respective Group; e.g. a test undertaken with 50 mm stud depth is applicable to 44 mm stud depth.

A result of a test undertaken with a construction in accordance with Group A covers studs in Groups A, B and C. A result of a test undertaken with a construction in accordance with Group B covers studs in Groups B and C. A result of a test undertaken with a construction in accordance with Group C covers studs in group C only.

The minimum dimension of the standard flexible construction shall be 3 m x 3 m unless other rules are given in the specific test standard.

The flexible construction may be installed by the test sponsor or the test laboratory as per agreement.

The materials for the flexible construction may be supplied by the test sponsor or the test laboratory as per agreement.

The test laboratory shall record the dimensions of the studs, the manufacturer of the gypsum boards and insulation material including the type, the thickness and the density of the gypsum boards and the insulation material used for the construction.

7.2.3 Non-standard supporting constructions

When the test specimen is intended to be used in a form of construction not covered by a standard supporting construction, it shall be tested within the supporting construction in which it is intended to be used.

8 Conditioning

8.1 Test specimen

At the time of the test, the strength and the moisture content of the test specimen shall approximate to those expected in normal service. The test specimen shall preferably not be tested until it has reached an equilibrium moisture content resulting from storage in an ambient atmosphere of 50 % relative humidity at 23 °C. If the test specimen is conditioned in a different way, it shall be clearly stated in the test report.

Concrete elements or specimens containing concrete parts shall not be tested until they have been conditioned for at least 3 months. Masonry elements shall not be tested until they have been conditioned for at least 28 days.

Concrete elements, which can contain large amounts of moisture, may take a very long time to dry out. Such specimens may be tested when the relative humidity at relevant positions of the specimen has reached 75 %. If the level of 75 % relative humidity cannot be reached within a reasonable time, measurements of the moisture content at the time of testing shall be measured and reported.

Guidance on conditioning and measuring of moisture content is given in Annex F.

8.2 Supporting constructions

When a test specimen is mounted within a supporting construction (e.g. a non-loadbearing wall mounted in a concrete or masonry wall supporting construction), full conditioning of the supporting construction may not be necessary if it can be demonstrated that there will be no influences on the behaviour of the specimen caused by excessive moisture. Excessive moisture can result in, for example, a lack of strength, spalling, moisture induced deformation, temperature influences etc. Any changes to the requirements for conditioning supporting constructions are given in the specific test method.

9 Application of instrumentation

9.1 Thermocouples

9.1.1 Furnace thermocouples (plate thermometers)

The plate thermometers employed to measure the temperature of the furnace shall be distributed so as to give a reliable indication of the average temperature in the vicinity of the test specimen. The number and position of plate thermometers for each type of element is specified in the specific test method.

Plate thermometers shall be positioned so that they are not in contact with flames from the furnace burners and that they are at least 450 mm away from any wall, floor or roof of the furnace.

At the commencement of the test, each plate thermometer shall be (100 ± 50) mm from the nearest point of the exposed face of the test construction and they shall be maintained at this distance during the test, as far as possible.

The method of support shall ensure that plate thermometers do not fall away or become dislodged during the test.

At the commencement of the test, the furnace shall include at least the number of plate thermometers (n) that are required by the specific test method. If plate thermometers fail so that there are $n-1$ in the furnace, the laboratory need take no action. If the number falls below $n-1$ during the test the laboratory shall replace the plate thermometers to ensure that at least $n-1$ are present, otherwise the test results are considered invalid.

Guidance on the use and maintenance of plate thermometers is given in Annex C.

9.1.2 Unexposed surface thermocouples

9.1.2.1 General

Where no evaluation of the test specimen against the insulation criteria is required, no unexposed surface thermocouples are applied. Where evaluation against the insulation criteria is required, surface thermocouples of the type described in 4.5.1.2 shall be attached to the unexposed face to measure the average and the maximum temperature rise.

Thermocouples should preferably be attached to the surface of the specimen by the use of heat resisting adhesive. There should be no adhesive between the copper disc and the specimen or between the copper disc and the pad, taking care to ensure that the air gap between them, if any, is a minimum. Where gluing is not possible, pins, screws or clips which are only in contact with those parts of the pad which are not over the disc shall be used. Further guidance on the application of unexposed face thermocouples is given in Annex C.

More specific information on the location of unexposed face thermocouples is given in the specific test method.

If unexposed surface thermocouples become heated by hot gases passing through the specimen, e.g. through a crack that develops during the test, then data from that thermocouple shall be excluded.

9.1.2.2 Average unexposed face temperature

The purpose of the average unexposed face temperature measurement is to determine the general level of insulation of the test specimen while ignoring particular hotspots. The average temperature rise on the unexposed surface is thus based upon measurements obtained from surface thermocouples located at or near the centre of the test specimen and at or near the centre of each quarter section.

For specimens which have regular changes of thickness such as corrugated or ribbed constructions, the number and location of thermocouples can be increased to have appropriate representation on the maximum and minimum thickness.

All thermocouples for determination of average unexposed face temperature shall avoid features, e.g. hotspots, by at least 50 mm. Examples of these are thermal bridges, joints, junctions and through connections and fixings such as bolts, screws etc. as well as locations where the thermocouples may be exposed to the direct impingement of gases passing through the test specimen.

Certain test methods include the concept of measuring the average unexposed face temperature rise separately for specimens which incorporate discrete areas of different thermal insulation. Rules for the application of thermocouples for determining the average unexposed face temperature for such specimens are given in the specific test method.

9.1.2.3 Maximum unexposed face temperature

The purpose of maximum unexposed face temperature measurement is to determine the level of insulation at those locations where higher temperatures are expected to occur. Thermocouples shall be attached for this purpose normally with a minimum of two thermocouples being applied for each type of joint/feature or location of concern. When positioning a thermocouple near a discontinuity, e.g. between adjacent panels in a wall, the centre of the disc shall not be placed closer than 20 mm to the discontinuity. Rules for the application of thermocouples for evaluating maximum unexposed face temperature rise are given in the specific test method. Minor hotspots due to fixings such as screws, nails or staples shall be ignored.

If the test specimen incorporates discrete areas ($\geq 0,1 \text{ m}^2$) that are evaluated separately with respect to average unexposed face temperature rise, then the evaluation of maximum unexposed face temperature rise of these areas also shall be undertaken separately. This may require extra unexposed surface thermocouples to be applied.

9.1.3 Internal thermocouples

When employed, internal thermocouples in accordance with 4.5.1.4 shall be fixed so as not to affect the performance of the test specimen.

Further guidance on the selection and application of internal thermocouples is given in Annex C.

9.2 Pressure

9.2.1 General

The pressure sensor (see 4.5.2) shall be located where it will not be subject to direct impingement of convection currents from the flames nor where it will be in the path of the exhaust gases. It shall be installed such that the pressure can be measured and monitored to provide the conditions specified in 5.2. The tubes shall be horizontal, both in the furnace and as they exit through the furnace wall, so that the pressure is relative to the same positional height from the inside to the outside of the furnace. Any vertical section of tube to the measuring instrument shall be maintained at ambient temperature.

9.2.2 Furnaces for vertical elements

One pressure sensor shall be provided to control furnace pressure. A second sensor may be used to provide information on the vertical pressure gradient within the furnace. This sensor, if used, shall be located at least one metre higher or lower than the first sensor.

9.2.3 Furnaces for horizontal elements

One pressure sensor shall be provided to control furnace pressure. A second sensor may be provided as a check on the first.

9.3 Deflection

Instrumentation for the measurement of deflection of the test specimen shall be located to provide data in terms of the amount and rate of deflection during and, where appropriate, subsequent to the fire test. Guidance on the application of deflection measurement for non-loadbearing vertical elements is given in Annex G.

10 Test procedure

10.1 Restraint application

Depending upon its design, relevant restraint may be provided by constructing the specimen inside a rigid frame. This method shall be used for partitions and for certain types of floors, as appropriate. In such cases, any gaps between the edges of the test specimen and the frame shall be filled with non-compressible material.

10.2 Load application

For loadbearing elements, the test load shall be applied at least 10 min before the commencement of the test and at such a rate that no dynamic effects are incurred. All resulting deflections shall be measured. If the test specimen consists of materials which incur appreciable deflections at test load level, the applied load shall be held constant prior to fire testing until the deflections are stabilised. Following their application and during the course of the test, the loads shall be kept constant, and when deflection of the test specimen takes place, the loading system shall respond quickly to maintain a constant value.

10.3 Commencement of test

Not more than 5 min before the commencement of the test, the initial temperatures recorded by all thermocouples shall be checked to ensure consistency and the datum values shall be established. Similar datum values shall be obtained, e.g. for deflection, as appropriate, and the initial condition of the test specimen shall be noted.

The initial average temperature of the internal thermocouples, if used, and of the unexposed surface temperature of the specimen shall be in the range of 10 °C to 40 °C and shall not differ from the initial ambient temperature (see 5.6) by more than 5 K.

Prior to the commencement of the test, the furnace temperature shall be less than 50 °C. The commencement of the test shall be considered the moment when the programme to follow the heating curve has been initiated (igniting the burners). The elapsed time shall be measured from this point and all manual and automatic systems for measurement and observation shall begin or shall be in operation at this time, and the furnace shall be controlled to comply with the temperature conditions specified in 5.1.

10.4 Measurements and observations

10.4.1 General

From commencement of the test, the following measurements and observations shall be taken, where appropriate.

10.4.2 Temperatures

Temperatures of all thermocouples (except the roving thermocouple) shall be measured and recorded at intervals not exceeding 1 min for the duration of the heating period. When using the roving thermocouple near a discontinuity e.g. between adjacent panels in a wall, the centre of the disc shall not be placed closer than 20 mm to the discontinuity, unless permitted by the specific test method.

A roving thermocouple as specified in 4.5.1.3 shall be applied to any suspected hot spot which develops during the test. There is no reason to retain application until steady state is obtained if a temperature of 150 °C is not achieved within an application period of 20 s. The restrictions on the use of the roving thermocouple are the same as those for fixed thermocouples (see 9.1.2.3). The roving thermocouple is only used for the evaluation of the test specimen against the maximum temperature criterion.

10.4.3 Furnace pressure

The furnace pressure shall be measured and recorded continuously or at intervals not exceeding 1 min.

10.4.4 Deflection

10.4.4.1 General

The relevant deflections of the test specimen shall be measured and recorded throughout the test.

10.4.4.2 Loadbearing test specimens

In the case of loadbearing test specimens, measurements shall be made prior to and following the application of the test load and at 1 min intervals during the heating period.

- a) For horizontal loadbearing test specimens, the measurements shall be made at the location where the maximum downwards deflection is expected to occur (for simply supported elements this is usually at mid span).
- b) For vertical loadbearing elements, axial deflection, which represents an increased height of the test specimen, shall be expressed positively; that which results in a decrease below the original height of the test specimen shall be expressed negatively.

10.4.4.3 Additional deflection measurements (loadbearing and non-loadbearing test specimens)

Where required by the specific test method, measurements of deflection shall be made at locations and frequencies to present a history of the movement of the test specimen. The relevant test method contains guidance on the location and frequency of measurement for the particular element under test. It may be important to increase the frequency of measurement around the time of integrity failure in order to generate information on extended application (see Annex G for further information).

10.4.5 Integrity

10.4.5.1 General

Unless otherwise specified in the relevant test method, the integrity of separating elements shall be evaluated throughout the test by cotton wool pads, gap gauges and monitoring the test specimen for evidence of sustained flaming.

10.4.5.2 Cotton pad

A cotton pad is employed by placing the frame within which it is mounted against the surface of the test specimen for a maximum of 30 s, or until ignition (defined as glowing or flaming) of the cotton pad occurs. The cotton pad shall be applied to all surfaces, including areas where either flames or hot gasses from a discontinuity, a crack or a gap are present.

During measurements, care shall be taken that there is at least 30 mm clearance between the surface of the pad facing the test specimen and the surface of the test specimen that is parallel to it. There shall also be at least 10 mm clearance between the periphery of the pad and any part of the test specimen. The cotton pad holder (see Figure 5) is provided with protuberances to maintain the appropriate separation between it and the test specimen. Small adjustments in position may be made so as to achieve the maximum effect from flames or hot gases.

The operator may undertake tests to evaluate the integrity of the test specimen. Such screening may involve selective short duration applications of the cotton pad to areas of potential failure and/or the movement of a single pad over and around such areas. Charring of the pad may provide an indication of imminent failure, but

a new pad shall be employed in the prescribed manner for an integrity failure to be confirmed. The pad shall be removed immediately once glowing or flaming of the pad occurs.

Charring of the cotton pad without flaming or glowing shall be ignored. The pad shall not be shaken or air blown across its surface after application. This will avoid igniting the pad when it should not otherwise do so.

The time of ignition, together with the location at which ignition occurred, shall be recorded.

10.4.5.3 Gap gauges

When gap gauges are used, the size of the opening in the surface of the test specimen shall be evaluated at intervals which will be determined by the apparent rate of the specimen deterioration. Two gap gauges shall be employed, in turn, and without undue force to determine:

- a) whether the 6 mm gap gauge can be passed through the test specimen, such that the gauge projects into the furnace, and can be moved a distance of 150 mm along the gap; or
- b) whether the 25 mm gap gauge can be passed through the test specimen such that the gauge projects into the furnace.

The gap gauges shall be used without undue force to enter through the gap or to traverse within the gap.

Any small interruption to the passage of the gauge that would have little or no effect upon the transmission of hot gases through the opening shall not be taken into account, e.g. a small fastening across a construction joint that has opened up due to distortion.

The time when it proves possible to enter a gap gauge into any opening in the test specimen in the prescribed manner, together with the location, shall be recorded.

10.4.5.4 Flaming

The occurrence and duration of any flaming on the unexposed surface, together with the location of the flaming, shall be recorded.

10.4.6 Load and restraints

For loadbearing elements, the time at which the test specimen is unable to support the test load shall be recorded. Any variation in measured forces and/or moments necessary to maintain an applied restraint condition shall be recorded.

10.4.7 General behaviour

Observations shall be made of the general behaviour of the test specimen during the course of the test and notes concerning phenomena such as smoke emission, cracking, melting, softening, spalling or charring etc. of materials of the test specimen shall be made.

10.5 Termination of test

The test may be terminated for one or more of the following reasons:

- a) safety of personnel or impending damage to equipment;
- b) attainment of selected criteria;
- c) request of sponsor.

The test may be continued after a failure under reason b) to obtain additional data for direct and/or extended application.

When a test has been terminated prior to failure under all of the relevant performance criteria, the reason for termination shall be stated. The result shall be given as the time of termination of the test and shall be qualified accordingly.

11 Performance criteria

11.1 Loadbearing capacity

This is the time in completed minutes for which the test specimen continues to maintain its ability to support the test load during the test. Support of the test load is determined by both the amount and the rate of deflection calculated from the measurements taken in 10.4.4.2. Since relatively rapid deflections can occur until stable conditions are reached, the rate of deflection criteria is not applied in the first 10 min of the fire test.

For the purposes of this standard, failure to support the load is deemed to have occurred when one of the following criteria have been exceeded:

a) For flexural loaded elements

Limiting deflection $D = \frac{L^2}{400 d} \text{ mm} ; \text{ Or}$

Limiting rate of deflection $\frac{dD}{dt} = \frac{L^2}{9000 d} \text{ mm} / \text{min}$

where

L is the clear span of the test specimen, in millimetres;

d is the distance from the extreme fibre of the cold design compression zone to the extreme fibre of the cold design tension zone of the structural section, in millimetres.

b) For vertically loaded elements

Limiting vertical contraction (negative elongation) $C = \frac{h}{100} \text{ mm}; \text{ or}$

Limiting rate of vertical contraction (negative elongation) $\frac{dC}{dt} = \frac{3h}{1000} \text{ mm} / \text{min}$

where

h is the initial height (in millimetres) of the test specimen once the load has been applied.

11.2 Integrity

These are the times in completed minutes for which the test specimen continues to maintain its separating function during the test without:

- a) causing the ignition of a cotton pad applied in accordance with 10.4.5.2; or
- b) permitting the penetration of a gap gauge as specified in 10.4.5.3; or

- c) resulting in sustained flaming.

The time of failure is the time at the end of the measurement; i.e. when the observation is finally made.

11.3 Insulation

This is the time in completed minutes for which the test specimen continues to maintain its separating function during the test without developing temperatures on its unexposed surface which:

- a) increase the average temperature above the initial average temperature by more than 140 K; or
b) increase at any location (including the roving thermocouple) above the initial average temperature by more than 180 K.

The initial average temperature shall be the average unexposed face temperature at the commencement of the test.

Some elements of construction have different limits of unexposed face temperature rise from those given above. These limits may apply to all or part of the specimen being evaluated. Details of the limits of temperature rise and the location of areas that are permitted to rise higher are given in the specific test method.

Where a specimen incorporates discrete areas of different thermal insulation, these shall be evaluated separately according to the specific test method for both average and maximum temperature rise criteria.

11.4 Consequential effects of failing certain performance criteria

11.4.1 Insulation and integrity versus loadbearing capacity

The performance criteria "insulation" and "integrity" shall automatically be assumed not to be satisfied when the "loadbearing capacity" criterion ceases to be satisfied.

11.4.2 Insulation versus integrity

The performance criteria "insulation" shall automatically be assumed not to be satisfied when the "integrity" criterion ceases to be satisfied.

12 Test report

12.1 Test report

The test report shall contain the following information.

- a) The name and address of the testing laboratory and its accreditation and/or Notified Body number as appropriate.
b) The name and address of the sponsor.
c) The date of the test.
d) The unique reference number of the test.
e) The name of the manufacturer (if known) of the test specimen and of the products and components used in the construction, together with identification marks and trade names.

- f) The constructional details of the test specimen, including description and drawings and principal details of components. The description and the drawings which are included in the test report shall, as far as practicable, be based on information provided by the sponsor and verified by a survey of the test specimen. When full and detailed drawings are not produced by the laboratory to be included in the report, then the sponsor's drawing(s) of the test specimen shall be authenticated by the laboratory and at least one copy of the authenticated drawing(s) shall be included in the report. Reference shall be given in the report that the drawings are those provided by the sponsor.
- g) The relevant properties of materials or components, such as density, thickness, moisture content, organic content, etc., that have a bearing on the fire performance of the test specimen. Where it is impracticable to measure some of these properties, this shall be reported.
- h) The method of assembly and installation of the test specimen.
- i) Details of pre-test conditioning of the test specimen.
- j) A statement concerning the laboratory's involvement in the selection of the test specimen.
- k) For loadbearing elements, the load applied to the test specimen, the basis for its calculation as provided by the sponsor and the method of loading, including the number and distribution of loading points.
- l) The support and restraint conditions employed and the rationale for their selection.
- m) For asymmetrical separating elements, the direction in which the specimen was tested and the reason for this choice.
- n) Information concerning the location of all thermocouples fixed to the specimen, pressure measurement and deflection measurement devices. Drawings shall be included which clearly illustrate the positions of the various devices and identify them relative to the data provided.
- o) The ambient temperature of the laboratory at the commencement of the test.
- p) The pressure conditions within the furnace related to the position of the test construction.
- q) Temperature/time curves of the furnace heating conditions.
- r) The reasons validating the test in the event of the tolerances on the temperature/time curve, pressure conditions or ambient laboratory conditions being inadvertently exceeded.
- s) The result stated in terms of the elapsed time, in completed minutes, between the commencement of heating and the time of failure with respect to the relevant criteria including:
- 1) the rate of deflection when this is the criterion used to assess loadbearing capacity, including the value of d used in calculating the limiting rate of deflection for flexural loaded elements;
 - 2) the maximum deflection and the time and position at which it occurred, supported by adequate graphical data;
 - 3) the mode of failure with respect to all integrity criteria;
 - 4) the position(s) at which the maximum temperature rise was measured should this be the cause of insulation failure;
 - 5) any alternative and additional tests in accordance with EN 1363-2, e.g. radiation.
- t) Tabular and/or graphical depiction of the output from all pressure measurement devices, deflection measurement devices, unexposed face thermocouples and, where applicable, internal thermocouples.

NOTE The report only needs to include a selection of the measured data sufficient to provide a history of the performance of the test specimen. For example, it is not necessary to tabulate the temperature of every thermocouple fixed to a beam at 1 min intervals for the whole duration of a 90 min test. However, it is recommended that all the measurements are included at around the time of failure of all the criteria being considered. Before and after this period, the interval at which measured data needs to be included in the report may be longer, e.g. 5 min to 10 min.

- u) A description of any significant behaviour of the test specimen.
- v) The field of direct application of the results for the specimen being evaluated, either in the form of the full text from the appropriate standard, or only those clauses which are relevant for the specimen tested.
- w) The following statements:

"This report details the method of construction, the test conditions and the results obtained when the specific element of construction described herein was tested following the procedure outlined in EN 1363-1, and where appropriate EN 1363-2. Any significant deviation with respect to size, constructional details, loads, stresses, edge or end conditions other than those allowed under the field of direct application in the relevant test method is not covered by this report."

"Because of the nature of fire resistance testing and the consequent difficulty in quantifying the uncertainty of measurement of fire resistance, it is not possible to provide a stated degree of accuracy of the result".

12.2 Expression of test results in the test report

An example of the method of expressing the test results is given below for a loadbearing separating element, where the integrity and insulation criteria were exceeded and the test was discontinued at the request of the sponsor before failure of loadbearing capacity of the test specimen:

- "Loadbearing capacity: 128 min no failure (the test having been discontinued at the request of the sponsor);
- Integrity - sustained flaming: 128 min no failure (the test having been discontinued at the request of the sponsor);
- Gap gauge: 124 min;
- Cotton pad: 120 min;
- Insulation: 110 min."

An example of the method of expressing the test results is given below for a non-loadbearing element incorporating two discrete areas of different thermal insulation:

- "Integrity - sustained flaming: 66 min, no failure (the test having been discontinued at the request of the sponsor);
- Gap gauge: 62 mins;
- Cotton pad: 42 min;
- Insulation area 1: 41 min;
- Insulation area 2: 25 min."

Dimensions in millimetres

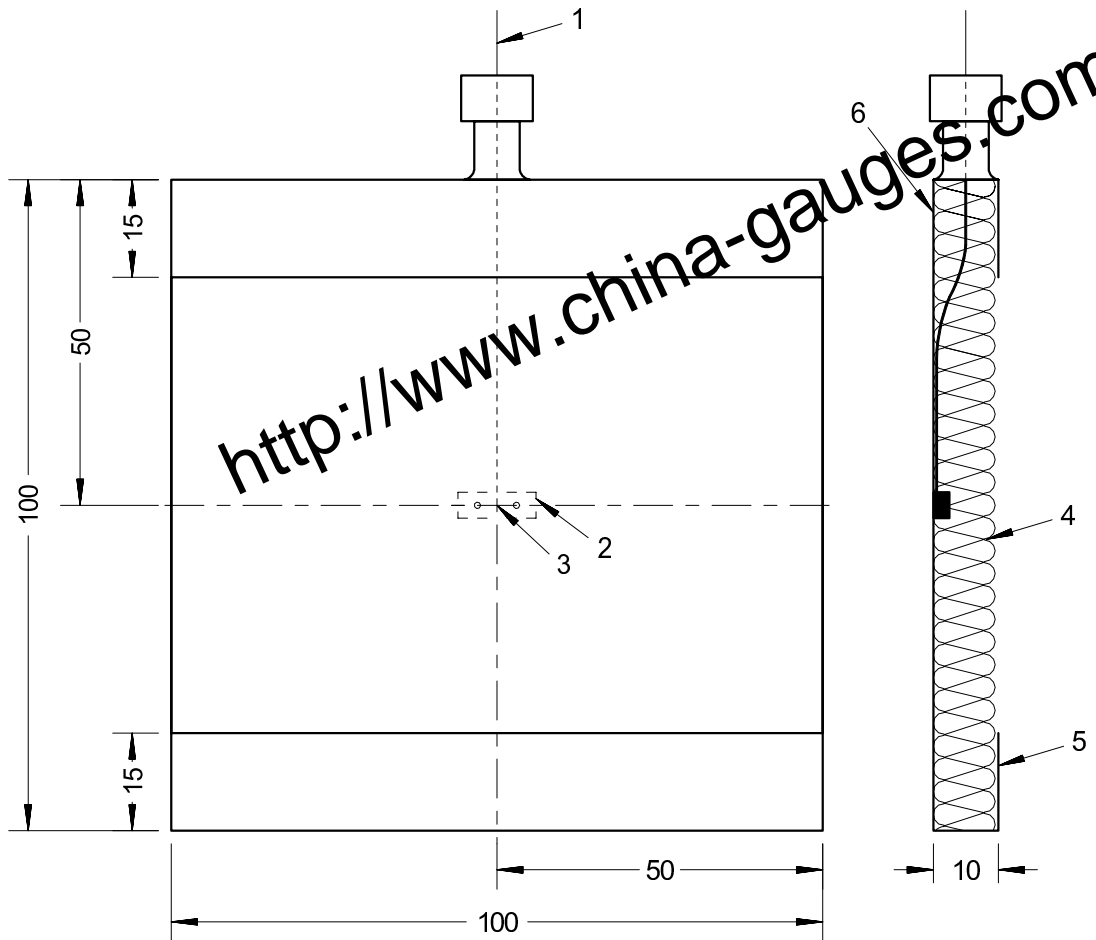

Key

- 1 sheathed thermocouple with insulated hot junction
- 2 spot welded or screwed steel strip
- 3 hot junction of thermocouple
- 4 insulation material (oriented towards the test specimen)
- 5 nickel alloy strip ($0,7 \pm 0,1$) mm thick
- 6 face 'A'

Figure 1 — Design of plate thermometer

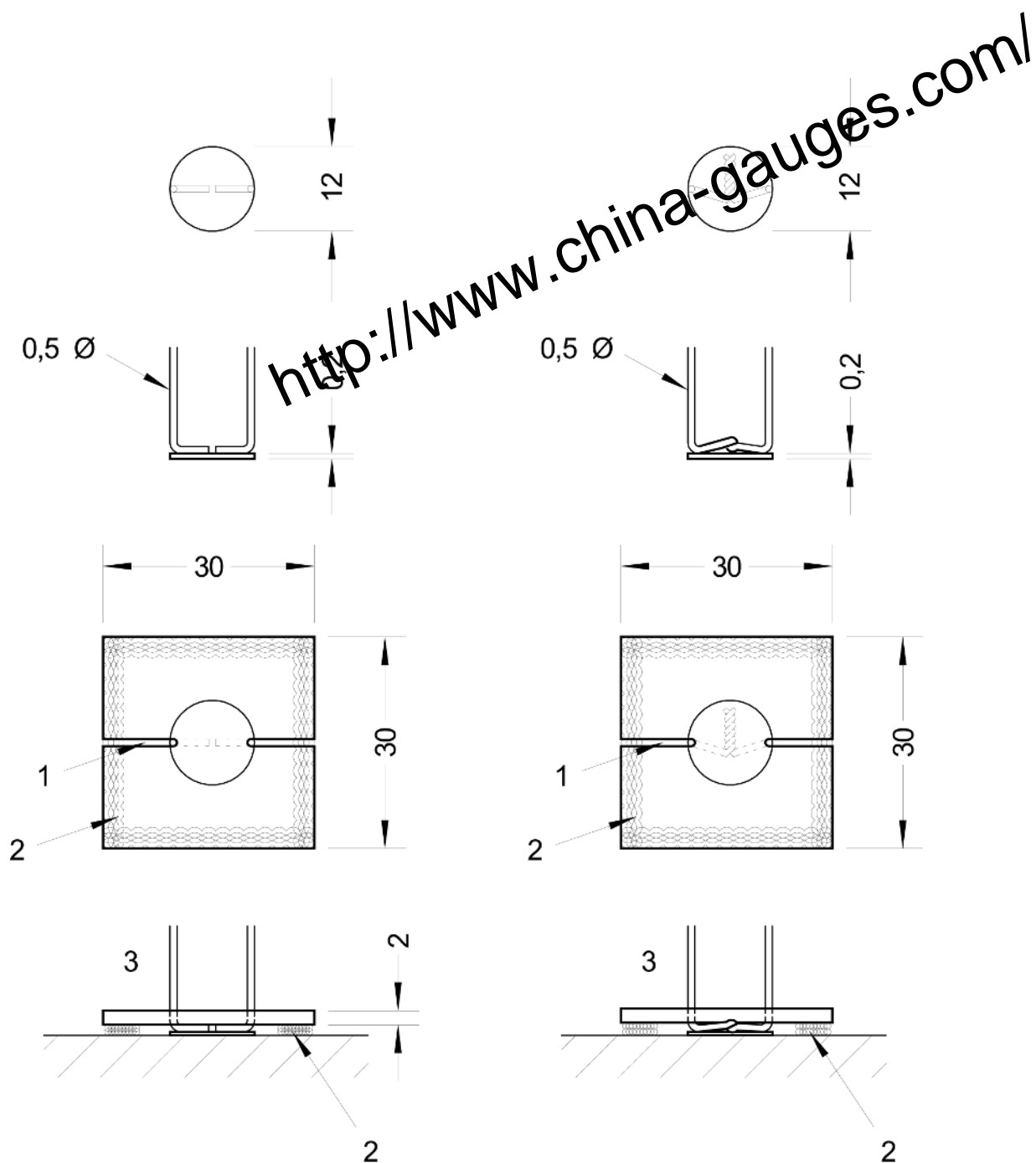

Key

- 1 examples of cuts to allow pad to be positioned over copper disc
- 2 example of location of adhesive between thermocouple and test specimen
- 3 copper disc and insulating pad bonded to surface of specimen

There shall be no adhesive between the copper disc and the surface of the test specimen or between the copper disc and the insulating pad.

Figure 2 — Examples of surface thermocouple junction and insulating pad

Dimensions in millimetres

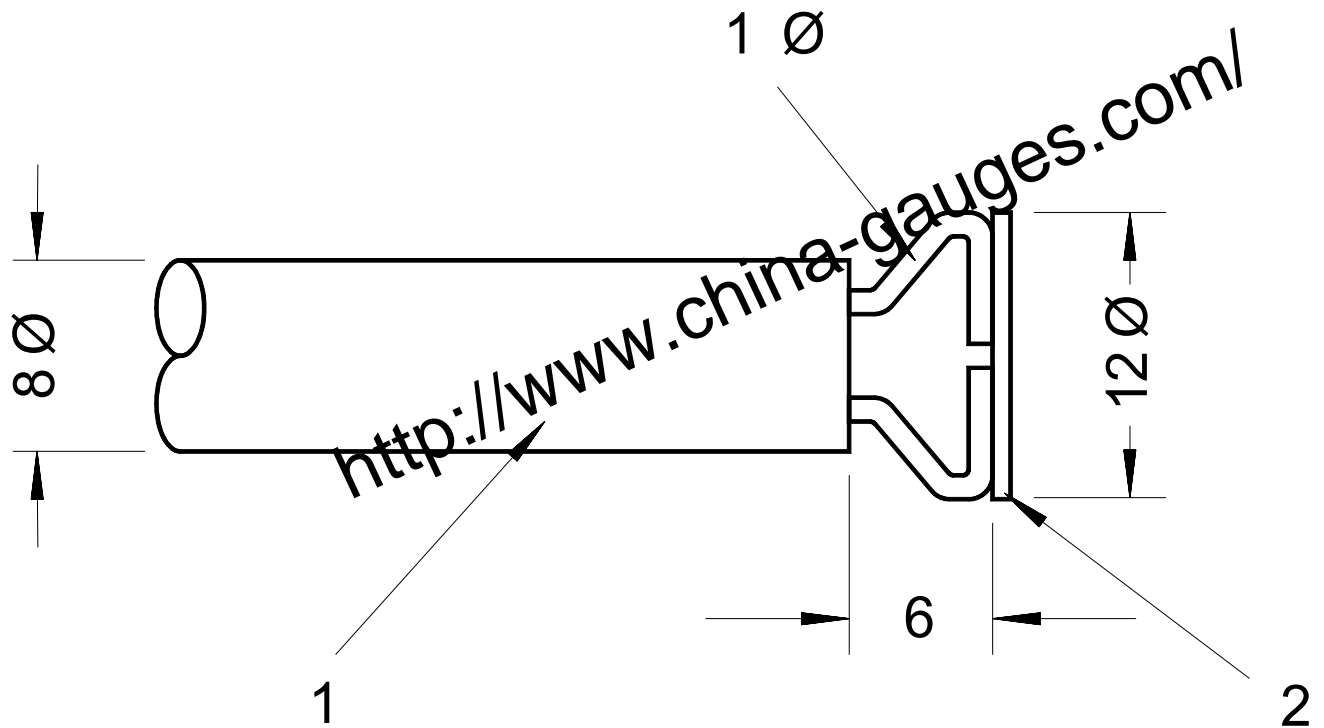

Key

- 1 twin bore ceramic carrier
- 2 0,5 mm thick copper disc

Figure 3 — Roving thermocouple assembly

Dimensions in millimetres

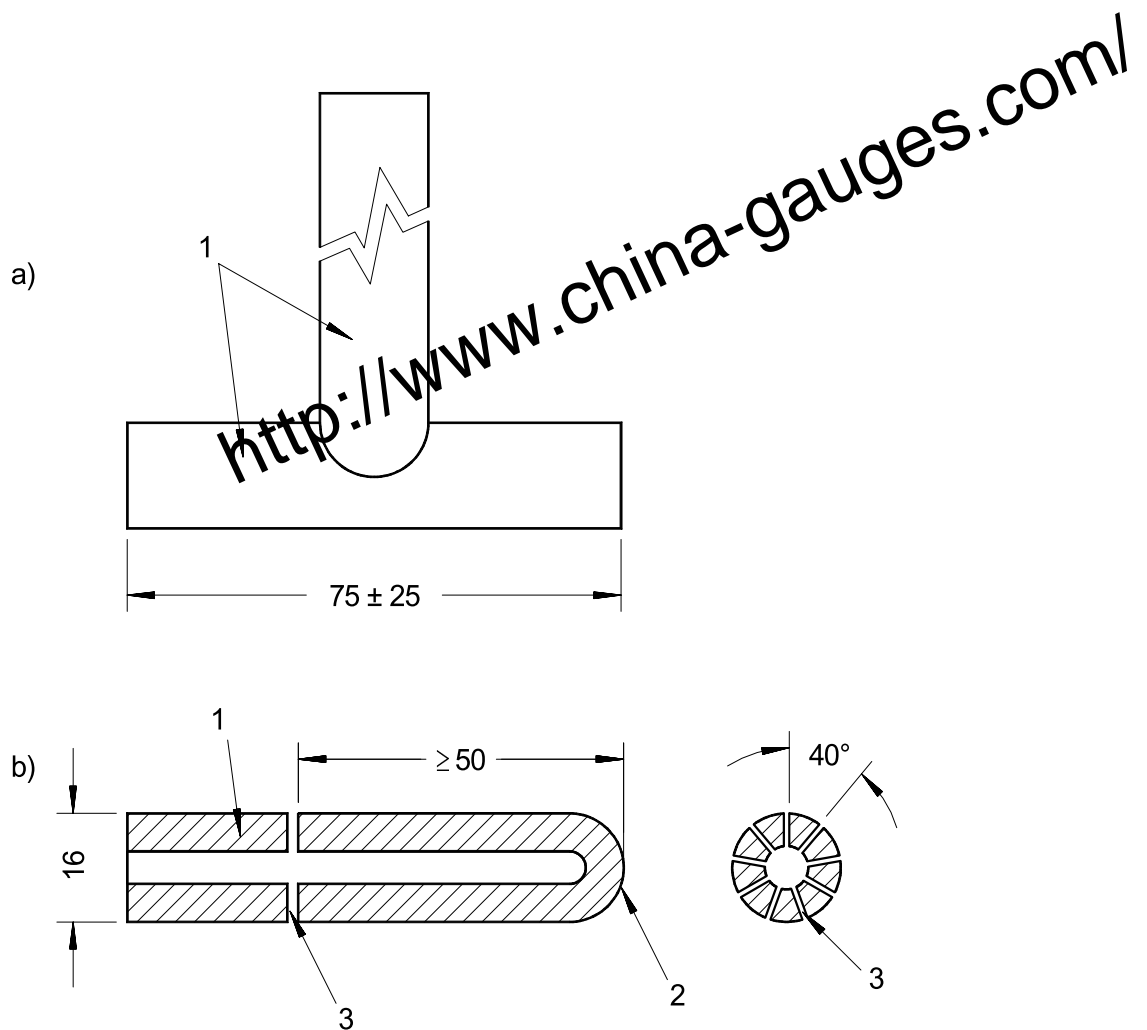

Key

- a) 'T' sensor
 - 1 stainless steel tube (inside diameter (7,5 ± 2,5) mm)
- b) tube sensor
 - 1 stainless steel pipe
 - 2 welded end
 - 3 1,2 mm diameter holes

Figure 4 — Pressure sensors

Dimensions in millimetres

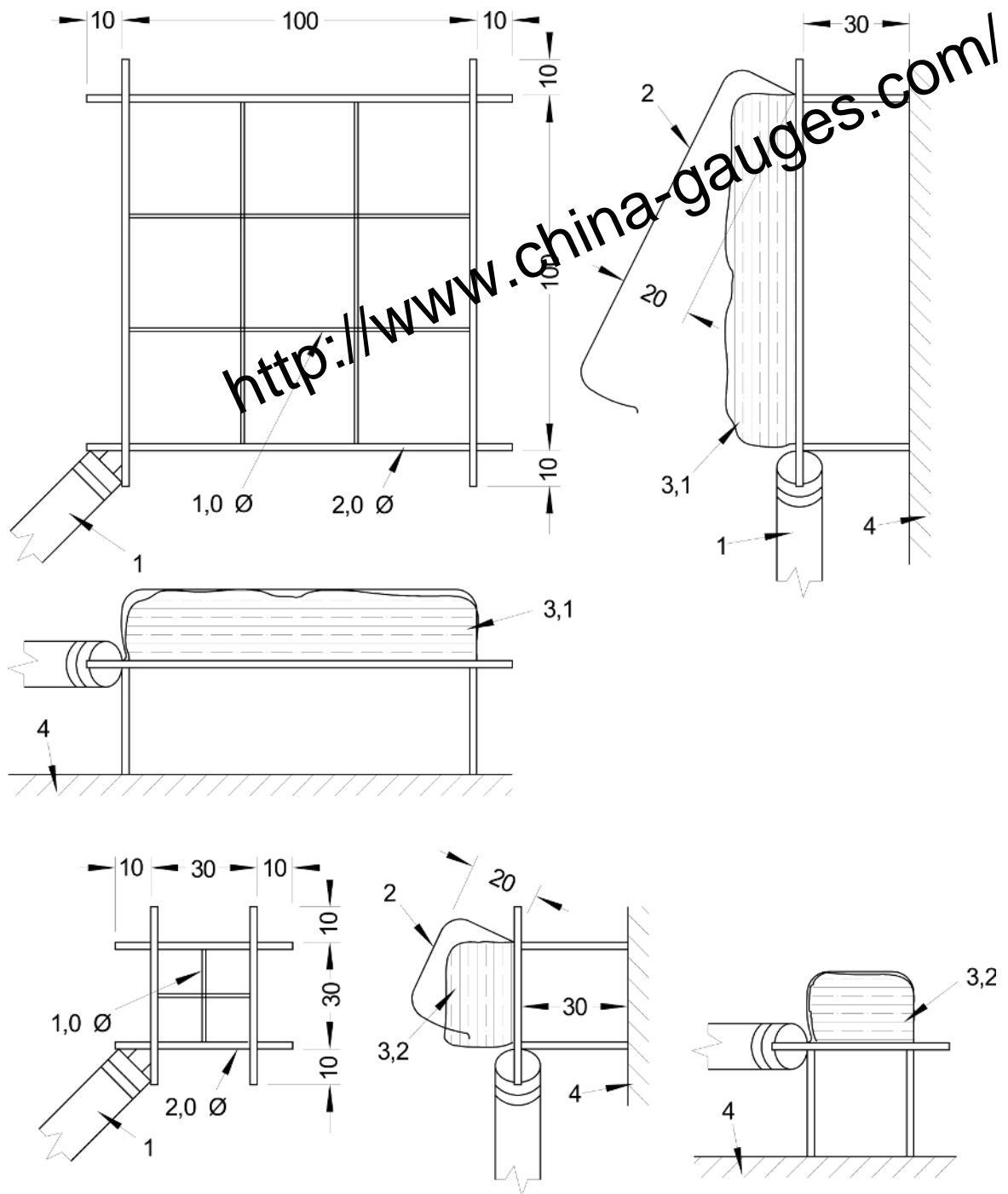

Key

- 1 handle
- 2 clip (open)
- 3.1 cotton pad 100 mm x 100 mm x 20mm, mass $(3,5 \pm 0,5)$ g
- 3.2 cotton pad 30 mm x 30 mm x 20 mm, mass $(0,3 \pm 0,1)$ g
- 4 surface of test specimen

Figure 5 — Frames for supporting the cotton pad

Dimensions in millimetres

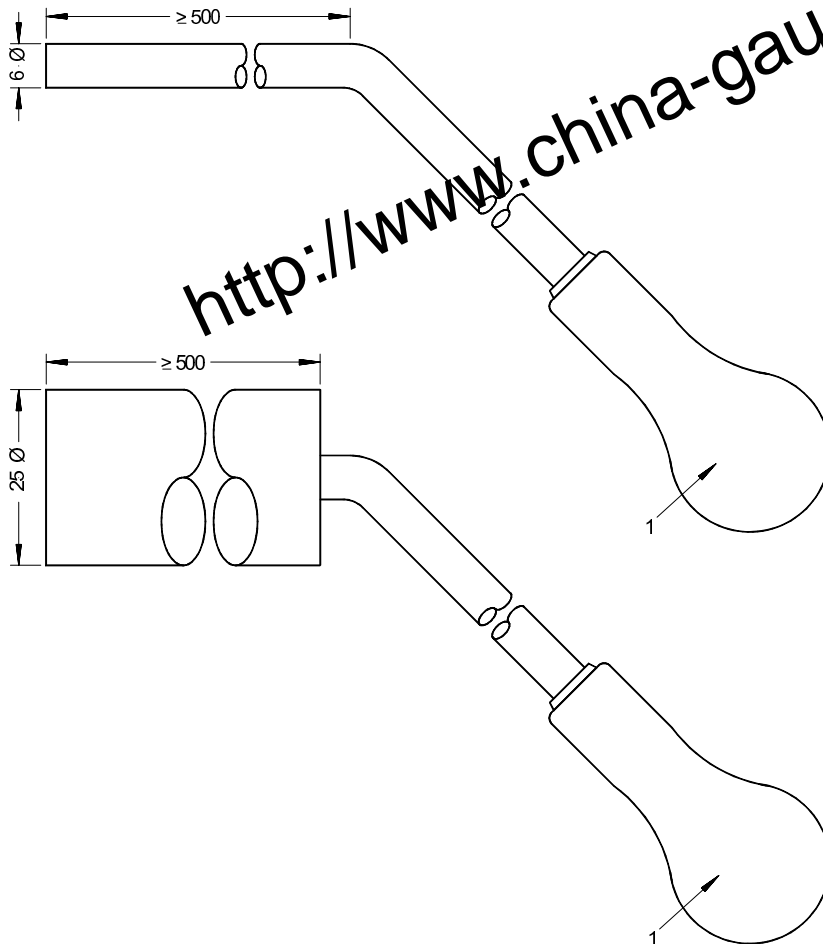

Key

1 insulated handle

Figure 6 — Example of gap gauges

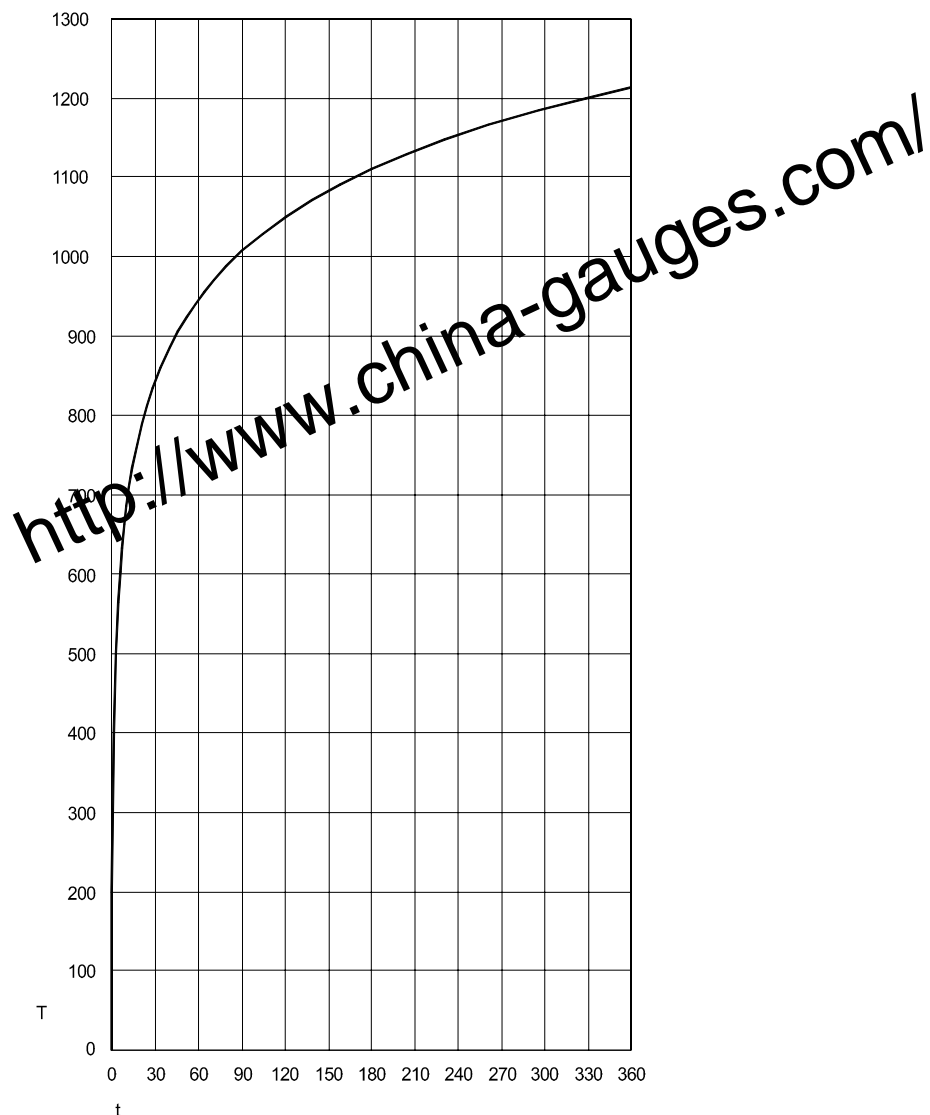

Key

T temperature °C
t time minutes

Time min	Furnace temperature °C	Time min	Furnace temperature °C
0	20	90	1006
5	576	120	1049
10	678	150	1082
15	738	180	1110
20	781	210	1133
30	842	240	1153
45	902	300	1186
60	945	360	1214

Figure 7 — Standard temperature/time curve

Dimensions in millimetres

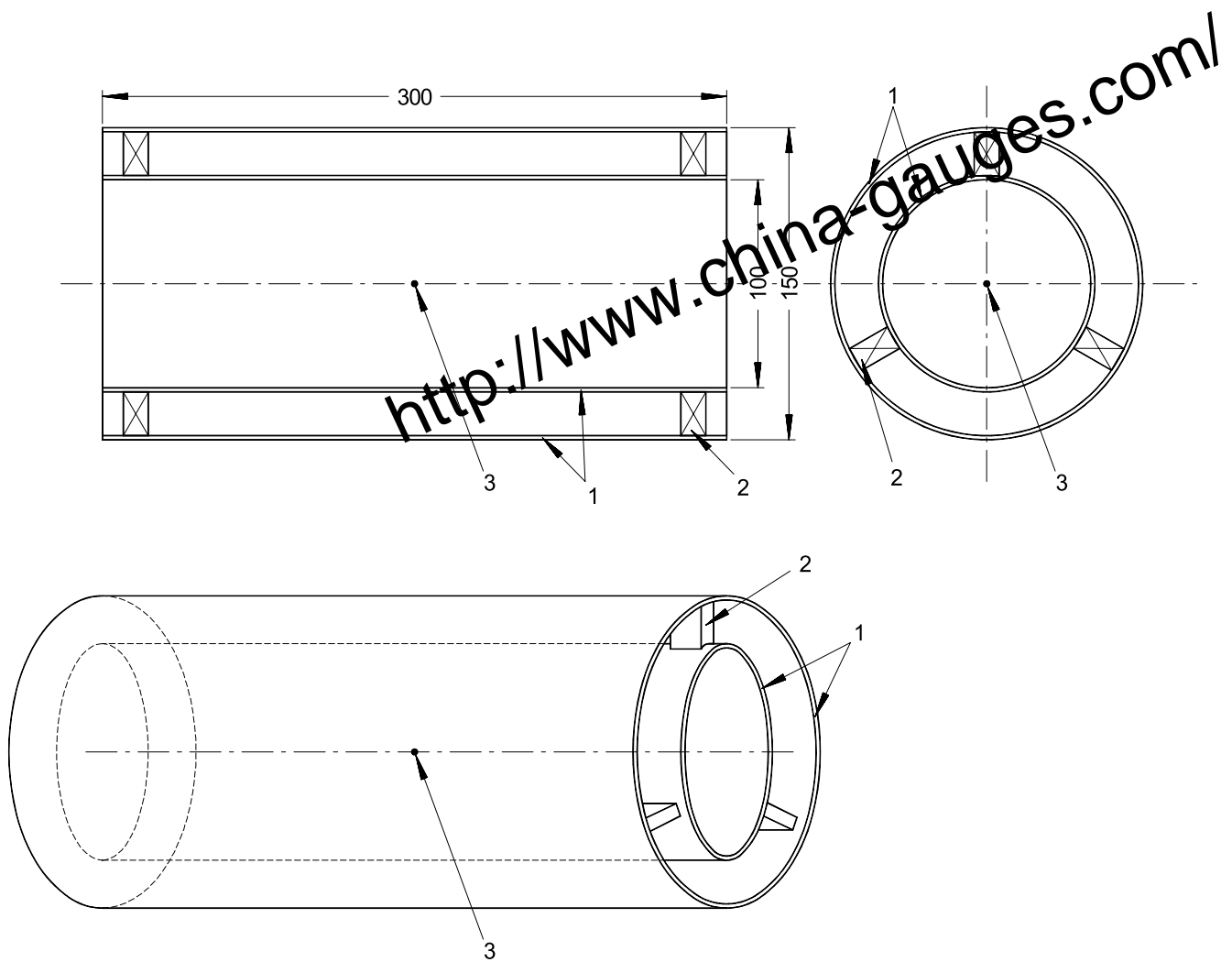

Key

- 1 concentric plastic pipes
- 2 spacer
- 3 position of ambient temperature measuring thermocouple

Figure 8 — Ambient temperature measuring device

Annex A (informative)

Field of application of test results

A.1 General

Most fire resisting products supplied by manufacturers are different from the specimens that were originally tested. Products are supplied in a wide variety of sizes, shapes and materials including finishes in order to satisfy the requirements of the market. It is impractical to test every variation of shape, size or material for each product. However, it is not acceptable, and it is often not permitted, for wide-sweeping variations of products to be supplied by the manufacturer without some form of recognised justification or approval. Therefore, there needs to be a mechanism by which variations from the tested specimen(s) can be accepted with a reasonable degree of confidence that such variants would perform equally well if they were subjected to the same test as the original test specimen.

A.2 Field of direct application

The extent to which a tested product may or may not be changed under the field of direct application is given in rules or guidelines which limit the permitted variation away from the test specimen without further evaluation or calculation. The field of direct application clause in each specific test method may relate to the more common forms of construction for which experience of testing has provided the knowledge that such variations can be safely accepted. The extent of the permitted variations are generally conservative as they are based on the minimum level of common agreement that can be achieved.

Such a series of rules allows building regulators and other bodies to accept the product without themselves having to make a judgement or request a professional opinion from a recognised authority. The variations that are permitted under direct application can be introduced automatically to manufactured products without additional assessment.

A.3 Extended application

There may be changes to the test specimen that cannot be dealt with by direct application. In addition, the types of rules given in direct application have been developed on the basis of individual test results and not on the concept of a series of tests on different sizes and/or variations of a product. Consequently, direct application does not cater for interpolation between results of different tests and will be of little use in extrapolation of a variable beyond the range of that tested.

Variations outside of the rules given in direct application and consideration of interpolation and extrapolation from a series of tests fall under the scope of extended application. This involves an in-depth review of the particular product design and performance in tests(s) by a recognised authority (Notified Body in the context of CE marking) that will produce an extended application report on the variation(s). The methodologies adopted in extended application are based on calculation methods or agreed expert opinions which are defined in extended application standards produced by CEN. Each extended application standard is written reflecting the philosophies employed in undertaking extended application for different elements.

Further information on direct and extended application reports can be found in EN 15725.

Annex B (informative)

The role of supporting constructions

B.1 General

Many elements that are tested for fire resistance are not mounted on the test furnace without being built into some type of construction between them and the furnace test frame. This may be because of their size: for example, most penetration seals and door assemblies are not large enough to close off the front or top opening of a furnace. In addition, the performance expected of an element is significantly influenced by the structure in which it is tested. For instance, in the case of doors, the performance of a door assembly mounted in a masonry or concrete wall is likely to be different (depending on the door type) than if it were mounted in a lightweight partition built from steel studs and boards.

It is necessary therefore to know the properties of these constructions in order to be able to determine the influence that they may have upon the element being tested. These constructions are known as supporting constructions because they support the test specimen in the test frame. They are normally divided into two types: standard supporting constructions and non-standard supporting constructions.

B.2 Standard supporting constructions

These are defined as forms of construction used to close off the furnace and support the test specimen being evaluated, which have a quantifiable influence on the heat transfer between the construction and the test specimen and which provide known resistance to thermally induced distortion. Examples of standard supporting constructions are lightweight plasterboard faced partitions, masonry walls and concrete walls. The standard supporting constructions are defined in 7.2.2. There may be more than one variety for each type of element being tested.

The standard supporting construction chosen for test will reflect the nature of the element being tested, the expected duration of the test and the field of direct application of the test result. For example, a four hour rolling shutter door designed for use in masonry or concrete walls would not be tested in a 30 min lightweight plasterboard standard supporting construction. Such a construction is unsuitable for supporting a rolling shutter door: it would fail soon after 30 min, rendering it insufficient for evaluating the performance of a four hour test specimen. The field of direct application for a test in a lightweight standard supporting construction does not automatically cover the test specimen for use in concrete or masonry constructions.

Some specific test methods have different standard supporting constructions. This is because the different methods evaluate the performance of the test specimen with respect to heat transfer between the construction and the test specimen, and resistance to thermally induced distortion in different ways.

B.3 Non-standard supporting constructions

These are defined as specific constructions in which the test specimen is to be installed in practice and which are not already covered by standard supporting constructions. Examples of non-standard supporting constructions are industrial pre-fabricated partitions, partitions faced with proprietary materials and special types of masonry wall.

The most important aspect of non-standard supporting constructions is that they are likely to have a much more restricted (if any) field of direct application than standard supporting constructions. This is because the influence on the heat transfer between the construction and the test specimen and the resistance to thermally

induced distortion are not known. These are the very properties of standard supporting constructions that allow a direct field of application for that type of supporting construction to be generated. Thus, tests in non-standard supporting constructions are of more limited value than those in standard supporting constructions.

<http://www.china-gauges.com/>

Annex C (informative)

General information on thermocouples

C.1 Furnace thermocouples (plate thermometers)

C.1.1 Maintenance

The plate thermometers specified in 4.5.1.1 are resistant to damage. They are nevertheless subject to damage by falling debris and deterioration in continued use, becoming slightly less sensitive with age. Before every test they should be inspected and checked for proper operation. If there is any evidence of damage, deterioration or improper operation they should not be used and should be replaced.

C.1.2 Positioning

Support for the plate thermometers should not penetrate or be attached to the specimen unless the specific requirements for the position of the measuring junction cannot otherwise be ensured. If the support for the measuring junction has penetrated or been attached to the specimen, it should be arranged so as to have minimal effect on the behaviour of the specimen in relation to the relevant failure criteria or the supplementary information being determined.

C.2 Internal thermocouples

C.2.1 General

Where information is required about the temperatures reached by individual components or parts of a specimen within its construction, thermocouples should be chosen of the appropriate type and design to suit the type of measurement to be made.

C.2.2 Specification

Internal thermocouples for measuring cavity temperatures within test specimens or of temperatures within materials such as concrete, steel, timber etc., should be made from double glass fibre insulated bare wire with wires of diameter 0,5 mm and crimped or welded junctions. The wires should remain insulated as close as possible to the junction. Any bare wires shall be kept as far apart as possible to minimise electrolytic effects. They should be used once only.

If the internal temperatures being measured are not likely to exceed 400 °C, then copper/constantan measuring junctions may be used; if higher temperatures are expected, the type K (chromel/alumel) junctions should be used.

C.2.3 Fixing methods and positioning

Appropriate methods should be adopted for fixing the measuring junctions securely to the components or the construction so that the thermal behaviour is not greatly disturbed.

For example, a junction can be peened to a heavy metal section by drilling a hole in the section only slightly larger in diameter than the thermocouple junction and deep enough to accommodate the junction below the surface. The junction can be inserted into the hole and burred over the edge of the hole with a punch to retain the wires in position. Alternatively, the hot junction can be welded to the section.

For light metal sections, the measuring junction can be placed under the head of a small bolt or rivet.

A similar junction can be attached to small metal components, such as screws or wires, by wrapping the tail around the component. In these applications, the first contact between the pair of thermocouple wires needs to be close to the surface whose temperature is being measured. The thermal contact can be improved by applying a little solder, which will remain effective even at temperatures above its melting point.

The thermal contact can be made by inserting the junction and the insulated leads into a hole with a suitable material of similar properties. Junctions and their leads may also be cast into materials such as concrete.

The wires from the junctions should, where possible, be taken along an isotherm for a distance of at least 50 mm and then to the outside of the specimen in such a way that they do not experience temperatures higher than the hot junction. There should be no joint or junction made in the wires until they emerge from the specimen.

The thermocouple wires should be protected against the following:

- a) excessive temperature rise;
- b) condensation;
- c) short circuiting by any aspect of the specimen construction or resulting from the heating conditions of test;
- d) damage resulting from the deformation of the specimen during the test.

C.3 Unexposed face thermocouples

C.3.1 General

Where a test specimen of a separating element is to be evaluated for its insulating properties, surface thermocouples will be fixed to its unexposed face in accordance with 9.1.2 and the detailed requirements in the specific test method.

C.3.2 Positioning

C.3.2.1 Flat surfaces

Mount the measuring junction on flat surfaces so that the whole of the surface of the copper disc is in intimate contact with the unexposed surface of the specimen. Fix the insulating pad to the surface of the specimen either by the use of a heat-resistant adhesive or by some mechanical means fixed through the area outside that covering the copper disc. Ensure that no adhesive gets between the disc and the surface of the specimen and that any mechanical device has an insignificant effect on the transmission of heat through the specimen to the copper disc.

On certain horizontal separating elements, especially those with visible insulation on the unexposed surface, this may not be suitable due to the fibrous or resilient nature of the materials in such situations. In these cases, a weight on the thermocouple or mechanical fixings, to keep the thermocouple in place, should be used in such a manner that air is free to circulate over the upper surface of the insulating pad.

C.3.2.2 Irregular surfaces

Where unexposed face copper disc thermocouples are to be attached to an irregular surface, a smooth surface of size 30 mm x 30 mm should be made to provide full contact. Where the surface cannot be smoothed, the thermocouple should be attached to the surface, around the edges of the disc only, by the use of a ceramic cement.

C.3.2.3 Small features

When it is required to apply a measuring junction to a small feature, do not apply the junction to a small feature, e.g. grooves or recesses, with a diameter less than 12 mm. Where the temperature of small features is to be measured, attach the thermocouple only where the small feature diameter is greater than 12 mm. If necessary, distort or cut the insulating pad but without affecting the part immediately over the disc.

C.3.3 Fixing to specific materials

C.3.3.1 General

In all cases of adhesive bonding, the adhesive should be applied in a thin film sufficient to give an adequate bond. There should be a sufficient lapse of time between the bonding of the thermocouples and the test for stable moisture conditions to be attained in the case of the ceramic adhesive and evaporation of the solvent in the case of the "contact adhesive".

C.3.3.2 Steel

The insulating pad with the thermocouple fitted should be bonded to the cleaned surface of the steel using a "water-based ceramic cement" produced by mixing the components to form a high temperature resistant adhesive. The adhesive should be of such a consistency that no mechanical aid is necessary for retention purposes during the drying process. Where difficulty in bonding is experienced, retention by adhesive tape may be employed provided that the tape is removed sufficiently long in advance of the test to allow complete drying of the adhesive. Care is required in the removal of the tape to ensure that the insulating pad is not damaged. If the thermocouple pad is damaged when the tape is removed then the thermocouple should be replaced.

C.3.3.3 Mineral wool

The thermocouples with insulating pads fitted should be arranged in such a way that if a surface wire mesh is present it may aid retention; and in all cases the bond to the fibrous surface should be made using a "contact adhesive". The nature of the adhesive necessitates a drying time before mating surfaces are put together thus avoiding the need for external pressure.

C.3.3.4 Mineral fibre spray

Thermocouples should not be fitted until the mineral fibre spray has reached a stable moisture condition. In all cases the bonding technique for steel should be used and where a surface wire mesh is present the thermocouples should be affixed to the insulation in such a way that the wire mesh aids retention.

C.3.3.5 Vermiculite/cement type spray

The technique specified for mineral fibrous spray should be employed.

C.3.3.6 Boards of fibrous or mineral aggregate composition

The bonding technique for steel should be used.

C.3.3.7 Timber

For many insulated timber constructions, the most practical way to fix thermocouples to the construction is to staple them through the pad into the timber. Care should be taken that the staples do not go through the disc or thermocouple wires or contact them in any way. Alternatively, a water based ceramic cement can be used as for attaching to steel constructions above.

C.3.3.8 Surfaces with applied finishes

Where a thermocouple is to be placed on a surface with a thin surface finish, e.g. paint, it is recommended that the surface finish first be removed with an abrasive before fixing the thermocouple.

<http://www.china-gauges.com/>

Annex D (informative)

Guidance on the basis for selection of the test load

D.1 General

The load applied to a test specimen during a fire test has a significant effect upon its performance as well as being an important consideration in the further application of the test data together with its relationship to data from other and similar tests. It is therefore the responsibility of the sponsor to inform on the service condition and agree the test load with the laboratory.

It is important to note that whatever method has been employed for developing the load during the fire test, it is desirable that it be related to the ultimate load of the test element before heating. Furthermore, it is essential that the basis for its development be clearly given in the test report as well as any other pertinent information such as material properties and stress levels which affect the significance and application of the test result. It should also be noted that the test load is not necessarily the same as that used in practice.

D.2 Options for selecting the test load

The widest application of test data is that which relates the determination of the test load (and hence the induced stresses) to the measured material properties of the actual structural members employed in the construction of the test specimen. At the same time, this causes material stresses to be developed in the critical areas of these members which are the maximum stresses permitted by the ultimate limit state design procedures in nationally recognized structural codes. This allows for the most severe application of the test load and provides a realistic basis for the extrapolation of test data and its use in calculation procedures.

In relating the required test load to the characteristic properties of the materials comprising the test specimen, the values may typically be provided by the material producer or may be obtained by reference to literature relating to the standard properties of the materials in question (usually given in a range). In most cases, this results in a low value for the test load, since actual values are generally higher than characteristic values. On the other hand, this practice relates more closely to typical national design procedures and the corresponding practices with regard to the specification of materials employed in building structures. The usefulness of the results obtained from such tests may be enhanced if the actual material properties are, nevertheless, determined and/or the actual stresses in the structural components of the fire test specimens are established during the fire test.

If the test load is related to a specific situation, its application to other situations is much more limited. The test load is invariably less than that which would normally be applied. Provided the structural members have been selected in consideration of their having to sustain normal design loads as provided by recognized structural codes, there will be a greater margin of safety and improved fire resistance when compared with the performance of test specimens loaded in accordance with the preceding paragraphs. Again, the usefulness of the test results may be improved if data can be obtained concerning the actual physical properties of the structural materials in the structural members and the stress levels obtaining in these members when loaded as prescribed.

Annex E (informative)

Boundary and support conditions

The boundary conditions may provide for restraint against expansion, contraction or rotation. Alternatively, the boundary conditions may offer freedom for movement to occur. A test specimen may be tested with one or another of these boundary conditions applied to all or only some of its edges. The choice of the conditions should be made on the basis of a careful analysis of the conditions that apply in practice.

Test specimens representative of elements with uncertain or variable boundary conditions in service should be supported at the edges or at the ends in such a manner as to provide conservative results.

If restraint is applied in the test, then the restraint conditions should be described with regard to the free movement of the element prior to encountering resistance to expansion, contraction or rotation. As far as possible, the external forces and moments which are transmitted to the element by restraint during the test should be recorded.

Restraint may be applied by the use of hydraulic or other loading systems. The restraining forces may be arranged so as to resist expansion and/or rotation. In such cases, the values of these restraining forces are useful information and should be measured at intervals throughout the test.

The requirements appropriate to each type of specimen are given in the specific test methods.

Annex F (informative)

Guidance on conditioning

F.1 General

The condition of the test specimen should, at the time of test, be similar with respect to its strength and moisture content as the element would be in normal service. This condition is considered as that which would be established at equilibrium resulting from storage in an ambient atmosphere of 50 % relative humidity at 23 °C.

The moisture content of any hygroscopic materials used in a construction has an influence when the specimen is exposed to fire conditions. High moisture contents can lead to the development of steam pockets which may cause delamination of board materials and spalling of concrete as well as producing unnaturally high moisture gradients, and hence distortions, in materials such as timber. Similarly, specimens with unrepresentatively low moisture contents can be affected by abnormal heat flow effects; in the case of jointed constructions there would be smaller shrinkage gaps than would be expected at higher moisture contents.

Under normal use conditions, it is anticipated that the moisture contents by mass of the common materials would be as specified below. It is recommended that these moisture levels with respect to dry weight as given in F.2 should exist in specimens being evaluated for internal use.

Timber:	All internal joinery applications	9 % to 12 %
	Structural loadbearing and non-loadbearing timber where the timber will be exposed or partially exposed to a heated or unheated internal environment	9 % to 12 %
	All other applications, including structural loadbearing and non-loadbearing timber where the timber will be insulated from the ambient internal conditions of the building	14 % to 18 %
Concrete and masonry:		1 % to 5 %
Gypsum based plasters:		Up to 2 %

Whilst these recommendations apply to the materials in the construction of the test specimen, the condition of the materials used in the construction of any associated construction or furnace closure may also influence the fire behaviour and hence some control should be exercised with respect to these components.

F.2 Guidance on procedures for conditioning

Any element will, if stored under constant temperature and moisture conditions, eventually come to an equilibrium. Therefore, if stored in 50 % relative humidity the moisture content in the pore system will correspond to that level of moisture content. As an example 50 % relative humidity for concrete corresponds to a moisture content of 1 % to 3 % and for wood of about 10 %. A moisture content of 5 % in concrete corresponds to a relative humidity of 100 %.

The water content can be measured by drying and weighing small pieces of the material. The relative humidity of a specimen can be measured easily in small holes in a test specimen (concrete, wood etc.) or by gathering pieces of the material in air tight plastic bags. Measurements of relative humidity can then be made when the air in the hole or in the bag respectively has reached an equilibrium with the material, typically within an hour.

In many cases, it is easier and more appropriate to determine the equilibrium moisture content by performing weighing operations on specially manufactured test pieces. These should be constructed so as to represent the loss of water vapour from the test specimen by having similar thicknesses and exposed faces. The test pieces should be conditioned to equilibrium as defined above.

Accelerated conditioning is permitted provided that the method does not alter the properties of component materials.

High temperature conditioning is permitted provided that the temperature is below critical temperatures for any of the materials in the test specimen.

An alternative to conditioning the complete test specimen is to assemble it from components previously conditioned in accordance with the requirements given above, provided that the assembly does not involve the use of hygroscopic materials.

The test methods for specific elements may contain additional or alternative guidance for obtaining moisture equilibrium.

F.3 Guidance on measurement techniques

F.3.1 Direct reading moisture meter

Direct reading moisture meters are a convenient method of determining the moisture content of finished specimens. The use of such meters is, however, subject to limitations in use. When meters are used for determining the moisture content of reinforced concrete, the steel reinforcement can easily cause errors in measurement due to the conductivity of the steel.

Similarly, composite timber materials such as plywood and glue laminated constructions will cause errors due to the conductivity of the glue lines. In these cases, insulated pin electrode meters should be used. While moisture meters are available for several materials they may not always determine the moisture content with sufficient accuracy. The use of meters should therefore be limited to those that have demonstrated a satisfactory correlation with oven drying techniques and even the use of these should be limited to homogeneous materials without composite construction. Where moisture meters are thought to be unsuitable, use should be made of oven drying techniques.

F.3.2 Oven drying techniques

When using oven drying techniques, the mean moisture content should be determined. In thick samples this will involve the removal of a core sample which extends from the surface to a point at mid-thickness. This sample should be weighed, and then dried in an oven operating at a temperature of $(105 \pm 5) ^\circ\text{C}$ (except for gypsum based products which should be dried at a temperature of $(50 \pm 5) ^\circ\text{C}$) until an equilibrium mass defined as when two successive weighings at 24 h intervals differ by less than 0,1% is reached. From the difference between two masses the moisture content can be calculated. Care should be taken that in the extraction of the core sample, the extraction process does not alter the moisture content of the core sample.

Annex G (informative)

Guidance on deflection measurements of vertical separating elements using a fixed datum

G.1 General

It is a requirement of 10.4.4.3 that horizontal deflection of test specimens is measured in order to present a history of the movement of the test specimen. This annex details a method for the measurement of horizontal deflection of vertical separating elements where deflection is not a failure criteria. This method does not prescribe the time interval between measurement or the locations at which measurements should be made. Details of these are given in the specific test methods.

G.2 Apparatus

The laboratory needs to provide a fixed datum positioned horizontally across the test specimen at the height at which the measurement is to be made. The datum may be a rigid bar, usually steel, or a wire under spring tension, (usually steel). The datum should be positioned some distance from the unexposed face of the test specimen to ensure that deflection away from the furnace by the test specimen does not result in it coming into contact with the datum. A distance of 150 mm is normally sufficient to ensure adequate clearance. The datum should also be such that it does not itself deform towards or away from the furnace due to heat emitted from the specimen.

The laboratory needs to provide a measuring device to determine the distance between the datum and the test specimen. A steel rule is usually sufficiently accurate for this.

G.3 Procedure

Before commencing test, the datum(s) should be fixed across the front of the test specimen at the height at which measurement is required. The specimen should be marked, e.g. with a series of letters A, B, C, etc, at the positions of measurement. In order to measure the values, the operator measures the distance between the datum and the specimen and records these as the time zero values. A table is a useful way of recording such data. Care should be taken not to damage the specimen during these measurements.

After commencement of the test, further readings should be made at suitable intervals in order to be able to provide a history of movement of the specimen. Care should be taken that the operator is not subjected to excessive heat due to close proximity to the test specimen. There are no fixed rules for these intervals but some suggestions are included below.

30 min test	-	Every 10 min up to 20 min. Every 5 min thereafter
60 min test	-	Every 10 min up to 50 min. Every 5 min thereafter
90 min test	-	Every 20 min up to 80 min. Every 5 min thereafter
120 min test	-	Every 20 min until 100 min. Every 10 min thereafter
180 min test	-	Every 30 min until 150 min. Every 10 min thereafter

240 min test Every 30 min until 210 min. Every 10 min thereafter

It may be advisable to reduce the time interval between measurements where it is observed that a specimen is failing before its anticipated failure time.

G.4 Reporting

Once all the measured values have been collected they need to be processed before they can be put into the report. It is important that the time zero measurements are subtracted from all other values to give the net movement. This may result in negative values - deflection away from the furnace - being produced. The values should be incorporated into the report in the form of a table or may be depicted graphically.

<http://www.china-gauges.com/>

Bibliography

- [1] ENV 1363-3, *Fire resistance tests — Part 3: Verification of furnace performance*
- [2] EN 15725, *Extended application reports on the fire performance of construction products and building elements*

<http://www.china-gauges.com/>

<http://www.china-gauges.com/>

British Standards Institution (BSI)

BSI is the independent national body responsible for preparing British Standards and other standards-related publications, information and services. It presents the UK view on standards in Europe and at the international level.

BSI is incorporated by Royal Charter. British Standards and other standardisation products are published by BSI Standards Limited.

Revisions

British Standards and PASs are periodically updated by amendment or revision. Users of British Standards and PASs should make sure that they possess the latest amendments or editions.

It is the constant aim of BSI to improve the quality of our products and services. We would be grateful if anyone finding an inaccuracy or ambiguity while using British Standards would inform the Secretary of the technical committee responsible, the identity of which can be found on the inside front cover. Similar for PASs, please notify BSI Customer Services.

Tel: +44 (0)20 8996 9001 Fax: +44 (0)20 8996 7001

BSI offers BSI Subscribing Members an individual updating service called PLUS which ensures that subscribers automatically receive the latest editions of British Standards and PASs.

Tel: +44 (0)20 8996 7669 Fax: +44 (0)20 8996 7001

Email: plus@bsigroup.com

Buying standards

You may buy PDF and hard copy versions of standards directly using a credit card from the BSI Shop on the website www.bsigroup.com/shop. In addition all orders for BSI, international and foreign standards publications can be addressed to BSI Customer Services.

Tel: +44 (0)20 8996 9001 Fax: +44 (0)20 8996 7001

Email: orders@bsigroup.com

In response to orders for international standards, BSI will supply the British Standard implementation of the relevant international standard, unless otherwise requested.

Information on standards

BSI provides a wide range of information on national, European and international standards through its Knowledge Centre.

Tel: +44 (0)20 8996 7004 Fax: +44 (0)20 8996 7005

Email: knowledgecentre@bsigroup.com

BSI Subscribing Members are kept up to date with standards developments and receive substantial discounts on the purchase price of standards. For details of these and other benefits contact Membership Administration.

Tel: +44 (0)20 8996 7002 Fax: +44 (0)20 8996 7001

Email: membership@bsigroup.com

Information regarding online access to British Standards and PASs via British Standards Online can be found at www.bsigroup.com/BSOL

Further information about British Standards is available on the BSI website at www.bsi-group.com/standards

Copyright

All the data, software and documentation set out in all British Standards and other BSI publications are the property of and copyrighted by BSI, or some person or entity that own copyright in the information used (such as the international standardisation bodies) has formally licensed such information to BSI for commercial publication and use. Except as permitted under the Copyright, Designs and Patents Act 1988 no extract may be reproduced, stored in a retrieval system or transmitted in any form or by any means – electronic, photocopying, recording or otherwise – without prior written permission from BSI. This does not preclude the free use, in the course of implementing the standard, of necessary details such as symbols, and size, type or grade designations. If these details are to be used for any other purpose than implementation then the prior written permission of BSI must be obtained. Details and advice can be obtained from the Copyright & Licensing Department.

Tel: +44 (0)20 8996 7070

Email: copyright@bsigroup.com

BSI

389 Chiswick High Road London W4 4AL UK

Tel +44 (0)20 8996 9001

Fax +44 (0)20 8996 7001

www.bsigroup.com/standards