

इंटरनेट

मानक

Disclosure to Promote the Right To Information

Whereas the Parliament of India has set out to provide a practical regime of right to information for citizens to secure access to information under the control of public authorities, in order to promote transparency and accountability in the working of every public authority, and whereas the attached publication of the Bureau of Indian Standards is of particular interest to the public, particularly disadvantaged communities and those engaged in the pursuit of education and knowledge, the attached public safety standard is made available to promote the timely dissemination of this information in an accurate manner to the public.

“जानने का अधिकार, जीने का अधिकार”

Mazdoor Kisan Shakti Sangathan

“The Right to Information, The Right to Live”

“पुराने को छोड़ नये के तरफ”

Jawaharlal Nehru

“Step Out From the Old to the New”

IS 302-2-6 (2009): Safety of household and similar electrical appliances, Part 2: Particular requirements, Section 6: Cooking Ranges, Hobs, Ovens and Similar Appliances [ETD 32: Electrical Appliances]



“ज्ञान से एक नये भारत का निर्माण”

Satyanarayan Gangaram Pitroda

“Invent a New India Using Knowledge”



“ज्ञान एक ऐसा खजाना है जो कभी चुराया नहीं जा सकता है”

Bhartrhari—Nitiśatakam

“Knowledge is such a treasure which cannot be stolen”

<http://www.china-gauges.com/>

<http://www.china-gauges.com/>

BLANK PAGE



भारतीय मानक

घरेलू और समान विद्युत साधित्रों की सुरक्षा

भाग 2 विशेष अपेक्षाएँ

अनुभाग 6 पकाने के रेंज, पकाने की मेज और अवन तथा समान साधित्र

(पहला पुनरीक्षण)

<http://www.china-gauges.com/>
Indian Standard

SAFETY OF HOUSEHOLD AND SIMILAR
ELECTRICAL APPLIANCES

PART 2 PARTICULAR REQUIREMENTS

Section 6 Cooking Ranges, Hobs, Ovens and Similar Appliances

(*First Revision*)

ICS 97.040.20; 13.020

© BIS 2009

BUREAU OF INDIAN STANDARDS
MANAK BHAVAN, 9 BAHADUR SHAH ZAFAR MARG
NEW DELHI 110002

FOREWORD

This Indian Standard (Part 2/Sec 6) (First Revision) was adopted by the Bureau of Indian Standards, after the draft finalized by the Electrical Appliances Sectional Committee had been approved by the Electrotechnical Division Council.

This standard was first published in 1993. This revision has been undertaken primarily to align the existing standard with corresponding latest International Standard and also to align with the revised version of Part 1 of this standard.

This standard covers the safety requirements of stationary cooking ranges, hobs, ovens and similar appliances, electric washing machines for household and similar use.

This standard does not cover the performance requirements. However, performance requirements of domestic electric cooking ovens are covered under a separate standard IS 5790 : 1985 'Domestic electric cooking ovens (*first revision*)' and single walled baking ovens are covered in IS 8985 : 1978 'Single walled baking ovens'.

It has been assumed in the formulation of this standard that the execution of its provisions is entrusted to appropriately qualified and experienced persons.

This standard recognizes the internationally accepted level of protection against hazards such as electrical, mechanical, thermal, fire and radiation of appliances when operated as in normal use taking into account the manufacturer's instructions. It also covers abnormal situations that can be expected in practice and takes into account the way in which electromagnetic phenomena can affect the safe operation of appliances.

This standard takes into account the requirements of IS 732 : 1989 'Code of practice for electrical wiring installations (*third revision*)' and SP 30 : 1985 'National electrical code' as far as possible so that there is compatibility with the wiring rules when the appliance is connected to the supply mains. However, national wiring rules may differ.

If an appliance within the scope of this standard also incorporates functions that are covered by another Part 2 of IS 302, the relevant Part 2 is applied to each function separately, as far as is reasonable. If applicable, the influence of one function on the other is taken into account.

This standard is a product family standard dealing with the safety of appliances and takes precedence over horizontal and generic standards covering the same subject.

An appliance that complies with the text of this standard will not necessarily be considered to comply with the safety principles of the standard if, when examined and tested, it is found to have other features that impair the level of safety covered by these requirements.

An appliance employing materials or having forms of construction differing from those detailed in the requirements of this standard may be examined and tested according to the intent of the requirements and, if found to be substantially equivalent, may be considered to comply with the standard.

This standard is to be read in conjunction with IS 302-1 (2008) 'Safety of household and similar electrical appliances: Part 1 General requirements'. For the sake of convenience, the clauses of this standard correspond to those of IS 302-1(2008), instead of reproducing full text of each clause, clauses of IS 302-1(2008) which are applicable (which means that relevant provisions of the clause apply) or not applicable and the subclauses or portion thereof which are not applicable are indicated as under:

- a) In case of a clause where it is applicable, the wording used is 'This clause of IS 302-1 (2008) is applicable/not applicable'; and
- b) In case of a subclause or part thereof 'Not applicable'.

(Continued on third cover)

(Continued from second cover)

Wherever a subclause of IS 302-1 (2008) is to be replaced by a new text, it has been indicated as under:

Replacement or Modification – followed by the new text.

Any addition to the existing provision of a subclause of IS 302-1 (2008) has been indicated as under:

Addition — followed by the text of the additional matter.

Clauses/Tables which are additional to those of IS 302-1 (2008) are numbered starting from 10 and additional subclauses are numbered with the main clause number followed by 101, 102, etc, for example 7.101.

Should, however, any deviation exist between IS 302-1 (2008) and this standard, the provisions of the latter shall apply.

This standard is based on IEC 60335-2-6 (2004) 'Safety of household and similar electrical appliances — Part 2-6: Particular requirements for stationary cooking ranges, hobs, ovens and similar appliances' issued by the International Electrotechnical Commission except for the following modification:

- a) The leakage current value is more stringent as compared to IEC Publication,
- b) Ambient test conditions are based on National conditions, and
- c) Schedule of type and acceptance test added.

Following changes have been incorporated in this revision:

- a) Additional requirements in **7.12** on marking and instruction included,
- b) Transient overvoltage (*see 14*) test added,
- c) Additional test for mechanical test added (*see 21.1*), and
- d) Additional requirements added in **22** (*see 22.120* and *22.121*).

For the purpose of deciding whether a particular requirement of this standard is complied with, the final value, observed or calculated, expressing the result of a test, shall be rounded off in accordance with IS 2 : 1960 'Rules for rounding off numerical values (*revised*)'. The number of significant places retained in the rounded off value should be the same as that of the specified value in this standard.

Indian Standard

SAFETY OF HOUSEHOLD AND SIMILAR ELECTRICAL APPLIANCES

PART 2 PARTICULAR REQUIREMENTS

Section 6 Cooking Ranges, Hobs, Ovens and Similar Appliances

(First Revision)

1 SCOPE

This clause of Part 1 is replaced by the following:

This standard deals with the safety of electric cooking ranges, hobs, ovens and similar appliances for household use, their rated voltage being not more than 250 V for single-phase appliances connected between one phase and neutral, and 480 V for other appliances.

NOTE 101 — Examples of appliances that are within the scope of this standard are:

- griddles,
- grills,
- induction hobs,
- pyrolytic self-cleaning ovens, and
- steam ovens.

As far as is practicable, this standard deals with the common hazards presented by appliances that are encountered by all persons in and around the home. However, in general, it does not take into account:

- the use of appliances by young children or infirm persons without supervision, and
- playing with the appliance by young children.

NOTE 102 — Attention is drawn to the fact that:

- for appliances intended to be used in vehicles or on board ships or aircraft, additional requirements may be necessary; and
- in many countries additional requirements are specified by the national health authorities, the national authorities responsible for the protection of labour, the national water supply authorities and similar authorities.

NOTE 103 — This standard does not apply to:

- appliances intended for commercial catering,
- appliances intended to be used in locations where special conditions prevail, such as the presence of a corrosive or explosive atmosphere (dust, vapour or gas),
- grills, toasters and similar portable cooking appliances (IS 302-2-9), and
- microwave ovens (IS 302-2-35).

2 REFERENCES

This clause of Part 1 is applicable except as follows:

Addition

IS No.	Title
IS/IEC 60584-1	Thermocouples — Part 1: Reference tables

3 TERMINOLOGY

This clause of Part 1 is applicable except as follows:

3.1.6 Addition

NOTE 101 — For appliances having more than three heating units per phase, a diversity factor is applied to the rated current or rated power input when determining the current used to establish the size of the terminals and the nominal cross-sectional area of the supply cord. The diversity factor F is calculated from the following formula, where N is the number of heating units per phase that can be energized together:

$$F = 0.35 + \frac{0.65}{\sqrt{N}}$$

3.1.9 Replacement

Normal Operation — Operation of the appliance as specified in **3.1.9.101** to **3.1.9.107**.

3.1.9.101 Hob elements, other than induction hob elements, are operated with vessels containing cold water. The vessel is made of unpolished commercial quality aluminium, has a flat bottom and is covered with a lid. Thermal controls are adjusted to their highest setting until the water boils and then adjusted so that the water boils gently. Water is added to maintain the level during boiling.

NOTE 1 — The lid is positioned so that steam does not affect the test.

In case of doubt, vessels as specified in Fig. 101 are used.

Induction hob elements are operated with vessels as specified in Fig. 102 that contain approximately half their capacity of cooking oil at room temperature.

Thermal controls are adjusted to their highest setting until the oil temperature reaches $180^{\circ}\text{C} \pm 4^{\circ}\text{C}$ and then adjusted so that this temperature is maintained.

For all hob elements the diameter of the bottom of the vessel is approximately equal to the diameter of the cooking zone and the quantity of liquid is specified in Table 101. The vessel is positioned centrally on the cooking zone.

NOTE 2 — If several cooking zones are marked for one hob element, the most unfavourable zone is used for the test.

NOTE 3 — For non-circular cooking zones, the smallest non-circular vessel is used which will cover the cooking zone as far as possible, taking into account the hob rim and the other vessels. The quantity of liquid is determined on the basis of the minor diameter of the cooking zone.

3.1.9.102 Ovens are operated empty with the door closed. Thermal controls are adjusted so that the mean temperature in the centre of the oven is maintained at:

- a) $220^{\circ}\text{C} \pm 4^{\circ}\text{C}$ for ovens with forced air circulation and
- b) $240^{\circ}\text{C} \pm 4^{\circ}\text{C}$ for other ovens.

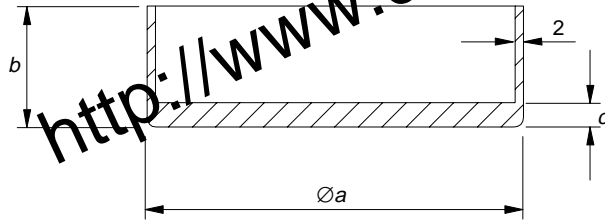

All dimensions in millimetres.

Diameter of Cooking Zone	Approximate Dimension		
	a	b	c
≤ 110	110	140	8
$>110 \leq 145$	145	140	8
$>145 \leq 180$	180	140	9
$>180 \leq 220$	220	120	10
$>220 \leq 300$	300	100	10

NOTE — The maximum concavity of the base of the vessel is to be not more than 0.05 mm. The base of the vessel is not to be convex.

FIG. 101 VESSEL FOR TESTING HOB ELEMENTS

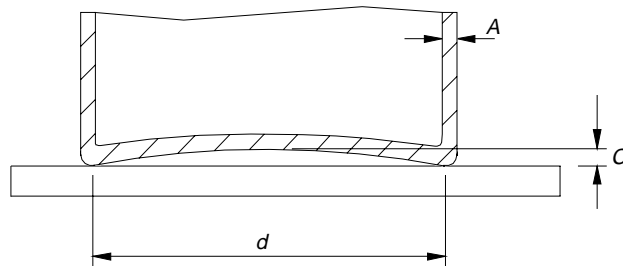

Key
 A = base and wall thickness, $2 \text{ mm} \pm 0.5 \text{ mm}$
 C = maximum concavity
 d = diameter of the flat area of the base

NOTE — The vessel is made of low carbon steel having a maximum carbon content of 0.08 percent. It is cylindrical without metallic handles or protrusions. The diameter of the flat area of the base of the vessel is to be at least the diameter of the cooking zone. The maximum concavity of the base of the vessel is $0.006 d$. The base of the vessel is not to be convex.

FIG. 102 VESSEL FOR TESTING INDUCTION HOB ELEMENTS

Table 101 Quantity of Liquid in the Vessel
(Clause 3.1.9.101)

Sl No.	Diameter of Cooking Zone	Quantity of Water or Oil
	mm	l
(1)	(2)	(3)
i)	≤ 110	0.6
ii)	> 110 and ≤ 145	1.0
iii)	> 145 and ≤ 180	1.5
iv)	> 180 and ≤ 220	2.0
v)	> 220 and ≤ 300	3.0

NOTE — If the temperature cannot be attained, the thermal control is adjusted to its highest setting.

Ovens without thermal controls are switched on and off so that the temperature in the centre of the oven is maintained at $240^{\circ}\text{C} \pm 15^{\circ}\text{C}$.

Steam ovens are operated in accordance with the instructions. Controls are adjusted to their highest setting until the cooking temperature is reached and then adjusted to the lowest setting that maintains this temperature.

Steam generators intended to be filled by hand are filled according to the instructions, water being added to maintain the steam generation.

Steam generators intended to be filled automatically are connected to a water supply, the pressure of which is set according to the instructions.

The supply water has a temperature of:

- $15^{\circ}\text{C} \pm 5^{\circ}\text{C}$ for appliances to be connected to a cold water supply; and
- $60^{\circ}\text{C} \pm 5^{\circ}\text{C}$ or the temperature indicated in the instructions, whichever is the higher, for appliances to be connected to a hot water supply.

Steam ovens are also operated while generating steam but with the thermal controls adjusted as for operation without steam.

3.1.9.103 Grills are operated empty with the grill pan and food supports in the most unfavourable position for normal use, the door and any other accessories being positioned in accordance with the instructions. In the absence of such instructions, the door and other accessories are placed in the most unfavourable position in which they may be left. Thermal controls are adjusted to their highest setting. However, if the instructions for grills incorporated in ovens specify a lower setting, this setting is used. Any reflectors intended to be placed above heating elements are in position.

3.1.9.104 Rotating spits in ovens or grills are operated

with the load on the rotating spit as shown in Fig. 103. The appliance is operated taking into account the instructions with regard to:

- the heating elements to be operated,
- the setting of the thermal control, and
- the position of the door and grill pan.

In the absence of such instructions, the control is adjusted to its highest setting and the door is fully open or is placed in the most unfavourable intermediate position in which it may be left.

Any grill pan is placed in its lowest position.

3.1.9.105 Warming drawers and similar compartments are operated in the closed position with their controls adjusted to the highest setting.

3.1.9.106 Griddles are operated so that the temperature at the centre of the heated surface is maintained at $275^{\circ}\text{C} \pm 15^{\circ}\text{C}$ by adjusting their thermal controls or by switching the supply on or off.

3.1.9.107 Cooking ranges are operated with their individual heating units being operated under their stated conditions of normal operation.

3.101 Oven — Appliance having a heated cavity with a door and constructed so that food, which may be in a container, can be placed on a shelf.

3.102 Grill — Heating unit constructed so that the food is supported on a grid or spit and is cooked by radiant heat.

NOTE — The cooking operation in a grill is known as grilling or broiling.

3.103 Hob — Appliance that incorporates a hob surface and one or more hob elements, and is built in or part of a cooking range.

3.104 Cooking Range — Appliance incorporating a hob and an oven and which may incorporate a grill or griddle.

3.105 Pyrolytic Self-Cleaning Oven — Oven in which cooking deposits are removed by heating the oven to a temperature exceeding 350°C .

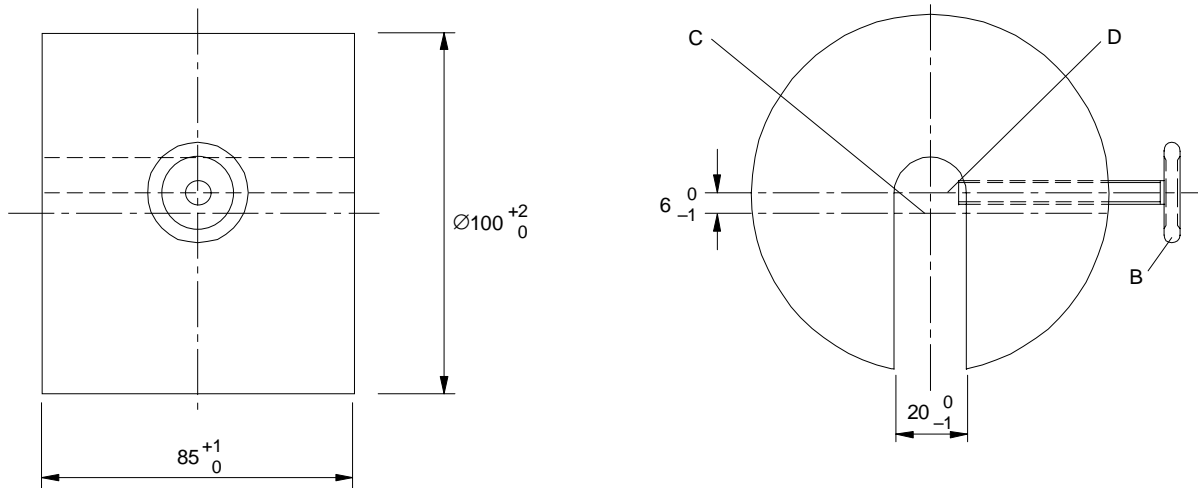
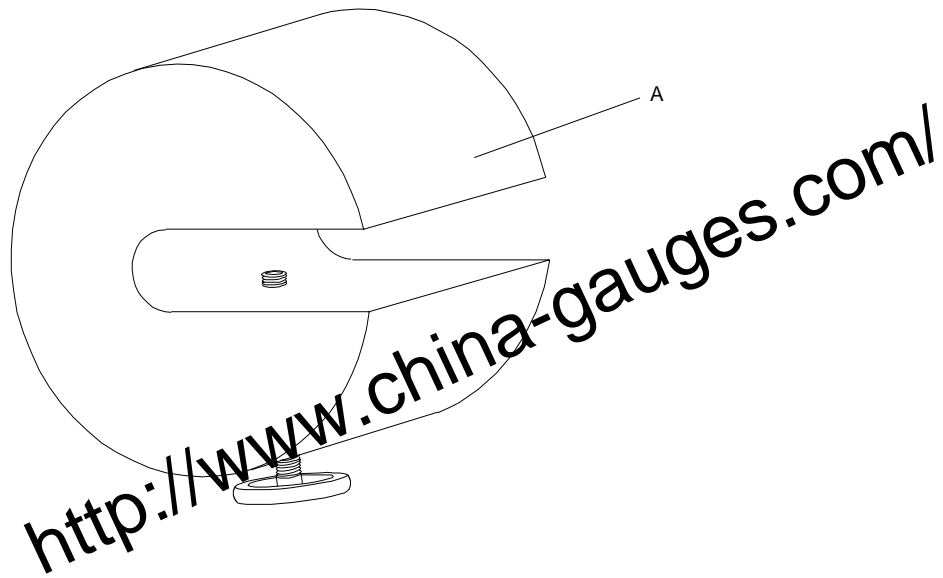

Key

A = load, mass approximately 4.5 kg
 B = fixing screw

C = axis of load
 D = axis of fixing screw

NOTE — The load is positioned on the rotary spit so that the fixing screw contacts the diameter of the spit.

All dimensions in millimetres.

FIG. 103 LOAD FOR TESTING ROTATING SPITS

3.106 Steam Oven — Oven intended for cooking food by steam generated at atmospheric pressure in the appliance.

3.107 Griddle — Heating unit having a surface on which the food is placed directly for cooking.

3.108 Induction Hob — Hob containing at least one induction hob element.

3.109 Heating Unit — Any part of the appliance that fulfils an independent cooking or warming function.

NOTE — Examples are hob elements, ovens, grills and warming drawers.

3.110 Hob Surface — Horizontal part of the appliance on which vessels can be placed.

3.111 Hob Element — Heating unit attached to the hob surface or positioned below the cooking zone.

3.112 Induction Hob Element — Hob element that heats metallic vessels by means of eddy currents.

NOTE — The eddy currents are induced in the bottom of the vessel by the electromagnetic field of a coil.

3.113 Pan Detector — Device incorporated in a hob element that prevents its operation unless a vessel is placed on the cooking zone.

3.114 Cooking Zone — Area marked on a hob surface where the vessel is placed for heating food.

NOTE — When a hob element protrudes above the hob surface, its surface is the cooking zone.

3.115 Touch Control — Control actuated by contact or proximity of a finger, with little or no movement of the contact surface.

3.116 Temperature-Sensing Probe — Device that is inserted into the food to measure its temperature and which is a part of an oven control.

3.117 Rated Water Pressure — Water pressure assigned to the appliance by the manufacturer.

4 GENERAL REQUIREMENTS

This clause of Part 1 is applicable.

5 GENERAL CONDITIONS FOR THE TESTS

This clause of Part 1 is applicable except as follows:

5.3 Addition

For pyrolytic self-cleaning ovens, the tests of **22.108** to **22.111** are carried out before the tests of **19**.

5.4 Addition

Appliances that also use gas are supplied with gas at the appropriate rated pressure. Vessels having a diameter of approximately 220 mm are filled with 2 litres of water, covered with a lid and placed on the hob burners. The controls are adjusted to their highest setting until the water boils. They are then adjusted so that the water simmers, water being added when necessary to maintain the level.

5.101 Class III temperature-sensing probes are only subjected to the tests of **19**.

6 CLASSIFICATION

This clause of Part 1 is applicable except as follows:

6.1 Modification

Appliances shall be class I, class II or class III.

7 MARKING AND INSTRUCTIONS

This clause of Part 1 is applicable except as follows:

7.1 Addition

The total rated power input or rated current of induction hob elements shall be marked.

If a cooking range incorporates a socket-outlet protected by means of fuses, other than D-type fuses, it shall be marked with the rated current of the relevant fuse. When a miniature fuse-link is provided, this marking shall indicate that the fuse-link is to have a high breaking capacity.

7.6 Addition

 ON/OFF (push-push)

7.10 Addition

The off position of touch controls for hobs shall be marked by the Fig. O and the on position by the Fig. I. If there is no touch control for the hob, this requirement applies to the touch controls for each hob element.

NOTE **101** — If the same touch control is used for switching on and off, symbol as given in **7.6** may be used.

7.12 Addition

If the hob surface is of glass-ceramic or similar material and protects live parts, the instructions shall include the substance of the following:

WARNING — If the surface is cracked, switch off the appliance to avoid the possibility of electric shock.

The instructions for cooking ranges and ovens shall include the substance of the following:

‘During use the appliance becomes hot. Care should be taken to avoid touching heating elements inside the oven’.

The instructions for ovens shall state the substance of the following:

WARNING — Accessible parts may become hot during use. Young children should be kept away.

The instructions for ovens having doors with glass panels shall include the substance of the following:

Do not use harsh abrasive cleaners or sharp metal scrapers to clean the oven door glass since they can scratch the surface, which may result in shattering of the glass.

If during the test of **11**, the temperature rise at the centre of the internal bottom surface of a storage drawer exceeds that specified for handles held for short periods in normal use, the instructions shall state that these surfaces can get hot.

The instructions for pyrolytic self-cleaning ovens shall state that excess spillage shall be removed before

cleaning and shall specify which utensils can be left in the oven during cleaning.

If, for cleaning, the manufacturer instructs the user to set the controls to a position higher than for normal cooking purposes, the instructions shall state that under such conditions the surfaces may get hotter than usual and children should be kept away.

The instructions for ovens incorporating a fan with a guard that can be removed for cleaning shall state that the oven shall be switched off before removing the guard and that, after cleaning, the guard shall be replaced in accordance with the instructions.

The instructions for ovens provided with a facility to use a temperature-sensing probe shall include the substance of the following:

‘Only use the temperature probe recommended for this oven’.

The instructions for cooking ranges, hobs and ovens shall state that a steam cleaner is not to be used.

The instructions for induction hobs shall include the substance of the following:

‘Metallic objects such as knives, forks, spoons and lids should not be placed on the hob surface since they can get hot’.

The instructions for hobs incorporating a lid shall state that any spillage should be removed from the lid before opening. They shall also state that the hob surface should be allowed to cool before closing the lid.

The instructions for hobs incorporating halogen lamps shall warn the user not to stare at the hob elements.

The instructions for hobs incorporating a pan detector shall include the substance of the following:

‘After use, switch off the hob element by its control and do not rely on the pan detector.’

If the appliance incorporates a lamp for illumination, and does not incorporate a switch providing full disconnection under overvoltage category III conditions, the instructions shall include the substance of the following:

WARNING — Ensure that the appliance is switched off before replacing the lamp to avoid the possibility of electric shock.

7.12.1 Addition

The installation instructions for cooking ranges that are placed on the floor shall state that if the range is placed on a base, measures have to be taken to prevent the appliance slipping from the base.

NOTE 101 — This statement is not required if the instructions specify that the range should not be placed on a base.

The installation instructions for appliances intended to be connected to the water mains shall include the maximum rated water pressure in megapascals.

7.12.3 Addition

If a cooking range does not have a supply cord, the instructions shall state the type of cord to be used, taking into account the temperature of the rear surface of the appliance.

7.12.4 Addition

The instructions for built-in appliances having separate control panels shall state that the control panel is only to be connected to the heating units specified in order to avoid a possible hazard.

7.15 Addition

When it is not practical for the marking of fixed appliances to be visible after the appliance has been installed, the relevant information shall be included in the instructions or on an additional label that can be fixed near the appliance after installation.

NOTE 101 — An example of such an appliance is a built-in hob.

The marking for the rated current of the fuse protecting a socket-outlet shall be placed on or near the socket-outlet.

7.101 Steam generators intended to be filled manually shall be marked with the maximum water level, which shall be visible during filling.

Compliance is checked by inspection.

7.102 The cooking zone of hob surfaces shall be identified by appropriate marking unless it is obvious.

Compliance is checked by inspection.

7.103 BIS Certification Marking

The appliances may also be marked with the Standard Mark.

7.103.1 The use of the Standard Mark is governed by the provisions of the *Bureau of Indian Standards Act*, 1986 and the Rules and Regulations made thereunder. The details of conditions under which the licence for the use of the Standard Mark may be granted to manufacturers or producers may be obtained from the Bureau of Indian Standards.

8 PROTECTION AGAINST ACCESS TO LIVE PARTS

This clause of Part 1 is applicable except as follows:

8.1.2 Addition

Test probe 12 of IS 1401 is applied without appreciable force to parts liable to be touched accidentally in normal use by a fork or similar pointed object. It shall not be possible to touch live parts.

8.1.3 Modification

The use of test probe 41 instead of test probe B and test probe 13 is only allowed when visibly glowing heating elements are situated at the top of an oven or grilling compartment.

9 STARTING OF MOTOR-OPERATED APPLIANCES

This clause of Part 1 is not applicable.

10 POWER INPUT AND CURRENT

This clause of Part 1 is applicable except as follows:

10.1 Addition

The power input of induction hob elements is measured separately and the tolerances for motor-operated appliances apply.

The contribution of a socket-outlet to the power input is considered to be 1 kW.

NOTE 101 — Socket-outlets are not loaded during the test.

10.2 Addition

The current of induction hob elements is measured separately and the tolerances for motor-operated appliances apply.

The contribution of a socket-outlet to the current is considered to be 1 kW divided by the rated voltage.

NOTE 101 — Socket-outlets are not loaded during the test.

11 HEATING

This clause of Part 1 is applicable except as follows:

11.1 Addition

For cooking ranges and ovens, compliance is also checked by the test of 11.101.

11.2 Addition

For appliances intended to stand on the floor, a closed rectangular box is placed as close as possible to the free side of the appliance and against the rear wall of the test corner. The box is made of dull black painted plywood 10 mm thick. It has a width of 150 mm, its top being level with the hob surface and its front flush with the front surface of the appliance.

Appliances having a lid to cover the hob surface are tested with the lid open. Lids that can be removed without the aid of a tool are removed, unless the hob element cannot operate with the lid removed.

Temperature-sensing probes are placed in the oven in any position likely to occur during normal use. They are not connected to control the oven temperature. The

test for pyrolytic self-cleaning ovens is carried out with temperature-sensing probes in position, unless otherwise specified in the instructions.

Detachable parts that are intended to be used to reduce the temperature of control panels are removed.

NOTE 101 — A retractable part is not considered to be a detachable part.

11.3 Addition

The temperature of the centre of the oven and the temperature rises of the surface of the rectangular box are determined using the thermocouples specified for the walls of the test corner.

NOTE 101 — If the magnetic field of an induction hob element unduly influences the results, the temperature rises can be determined using platinum resistances with twisted connecting wires or any equivalent means.

11.4 Addition

Induction hob elements are supplied separately and operated as specified for motor-operated appliances.

Cooking ranges are operated at 1.15 rated power input under normal operation. The supply voltage is measured when the power input has stabilized. This voltage is used to supply the heating units of the cooking range during the tests.

11.6 Replacement

Combined appliances are operated as specified for heating appliances.

If the temperature rise limits are exceeded in appliances incorporating motors, transformers or electronic circuits, and the power input is lower than the rated power input, the test is repeated with the appliance supplied at 1.06 times rated voltage.

11.7 Replacement

Appliances are operated for the duration specified in 11.7.101 to 11.7.106.

NOTE 101 — Steady conditions are considered to be established if the temperature does not rise by more than 1 K in 15 min.

11.7.101 Induction hob elements are operated for 30 min. Other hob elements are operated for 60 min.

11.7.102 Ovens are operated for 60 min. If a rotating spit is provided, it is in operation.

NOTES

- 1 Steam ovens are operated in each mode of operation.
- 2 Lamps in ovens are not manually switched on.

If an appliance incorporates two ovens that can be energized simultaneously, they are tested together.

Pyrolytic self-cleaning ovens are also operated under

the cleaning conditions specified in the instructions for the maximum time allowed by the control or until steady conditions are established, whichever is shorter. During this period, other heating units that can be energized are operated under normal operation.

11.7.103 Grills are operated for 30 min. However, grills having means to reduce the power input are operated for 15 min with their controls adjusted to the highest setting and then for 15 min at a setting which reduces the average power input by approximately 50 percent.

Grills provided with a rotating spit are also operated with the spit rotating for 60 min.

11.7.104 Griddles incorporating a thermal control are operated until steady conditions are established. Other griddles are operated for 30 min after the centre of the heating surface attains a temperature of 275°C.

11.7.105 Warming drawers and similar compartments are operated for 30 min.

11.7.106 For cooking ranges, combinations of heating units that can be energized simultaneously are tested together for the durations specified in **11.7.101** to **11.7.105**, heating units that have a test duration of 30 min being operated for the last 30 min of the test.

NOTE — For example, the sequence of tests for a cooking range incorporating a grill in the oven and a rotating spit is as follows:

- Operation of the hob and oven and, if possible, with the spit rotating, for 60 min;
- Cooling down to approximately room temperature;
- Operation of the hob for 60 min, the grill being operated simultaneously for the last 30 min;
- Cooling down to approximately room temperature; and
- Operation of the hob and grill with the spit rotating, for 60 min.

11.7.107 If the appliance incorporates a socket-outlet, an appropriate plug complying with IS 1293 is engaged. The plug is connected to a 1 kW resistive load by means of an ordinary polyvinyl chloride sheathed flexible cord as per IS 694 having a cross-sectional area of 0.75 mm². The temperature rise of the plug is determined during the last 30 min of the test.

11.8 Modification

Instead of the temperature rises stated in Table 3 for wood, the following applies.

Temperature rises of the floor and walls of the test corner, wooden cabinets and the rectangular box shall not exceed the following values:

- | | |
|--|------|
| a) Appliances intended to stand on a table | 65 K |
| b) Grills | 75 K |
| c) Other appliances | 70 K |

The temperature rise of parts of the underside of built-in hobs, accessible to a 75 mm diameter probe having a hemispherical end, shall not exceed 70 K unless the instructions specify that a board is to be installed underneath the hob.

Addition

The temperature rise of handles of inner glass doors, grill pans, temperature-sensing probes and rotating parts in ovens or grills is not limited.

During an additional test for pyrolytic self-cleaning ovens, the temperature rise of the surface of knobs, handles and levers shall not exceed the following values:

- | | |
|-------------------------------------|------|
| a) Metal | 55 K |
| b) Porcelain or vitreous material | 65 K |
| c) Moulded material, rubber or wood | 80 K |

The temperature rises of knobs, handles and levers associated with functions that cannot be performed during the cleaning operation are not determined.

The temperature rise limits of motors, transformers and components of electronic circuits, including parts directly influenced by them, may be exceeded when the appliance is operated at 1.15 times rated power input.

The temperature rise of the plug, measured 2 mm below the surface at the centre of the engagement face, shall not exceed 45 K.

11.101 Cooking ranges and ovens are placed as specified in **11.2**. However, appliances intended to stand on the floor are positioned with their backs against one of the walls of the test corner and away from the other wall. A rectangular box as specified in **11.2** is placed against one of the sides of the appliance. The appliance is supplied at rated voltage and operated under normal operation.

All heating units, other than grills, that can be connected to the supply mains at the same time during normal use are switched on.

Ovens are operated without accessories. The mean temperature in the centre of the oven is maintained at 200°C ± 4°C.

Hob elements and griddles are operated in accordance with **11.7**.

Warming drawers and similar compartments are operated with the controls adjusted to the highest setting.

The appliance is operated for 60 min or until steady conditions are established, whichever is shorter.

Temperature rises of the front and side surfaces are measured using the probe of Fig. 104. The probe is applied with a force of $4\text{ N} \pm 1\text{ N}$ to the surface in such a way that the best possible contact between the probe and the surface is ensured.

NOTE 1 — Any measuring instrument giving the same results as the probe may be used.

Temperature rises are not measured on:

- a) surfaces that are inaccessible to a 75 mm diameter probe having a hemispherical end, unless they are protected by a detachable guard;
- b) surfaces of cooking ranges that are within 25 mm below the level of the hob surface or are above the hob surface;
- c) small parts such as oven vents, hinges and trim where the width of the accessible surface is less

than 10 mm; and

- d) surfaces within 10 mm of the edge of the oven door.

During the test, the temperature rise of surfaces shall not exceed the values specified in Table 102.

NOTE 2 — If the door is protected by a guard, the temperature rises specified for the front surface of oven doors apply to the guard.

However, for oven doors the temperature rise limits specified for other parts apply to:

- a) parts protected by a detachable guard,
- b) those parts of the door of built-in ovens situated more than 850 mm above the floor after installation of the oven, and
- c) ovens intended to be used on a working surface.

Table 102 Temperature Rise Limits for Accessible Surfaces
(Clause 11.101)

Sl No.	Surface	Temperature Rise, K	
		Front Surfaces of Oven Doors	Other Parts
(1)	(2)	(3)	(4)
i)	Metal and painted metal	45	60
ii)	Vitreous-enamelled metal	50	65
iii)	Glass and ceramic	60	80
iv)	Plastic having a thickness exceeding 0.3 mm	80	100

NOTES
1 The temperature rise limit of 100 K also applies for plastic material having a metal finish of thickness less than 0.1 mm.
2 When the thickness of the plastic coating does not exceed 0.3 mm, the temperature rise limits of the supporting material apply.

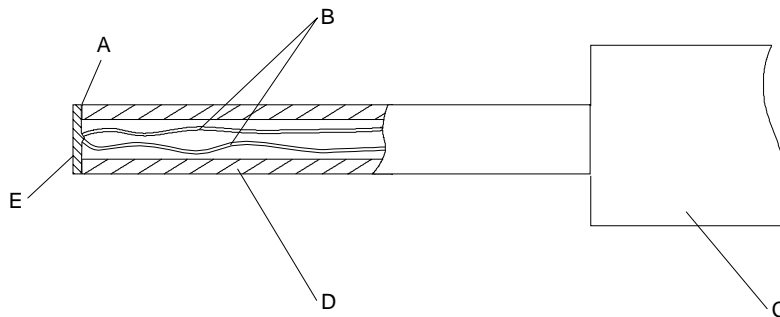

Key

- A = adhesive
- B = thermocouple wires 0.3 mm diameter (chrome alumel)
- C = handle arrangement permitting a contact force of $4\text{ N} \pm 1\text{ N}$
- D = polycarbonate tube: inside diameter 3 mm, outside diameter 5 mm
- E = tinned copper disc: 5 mm diameter, 0.5 mm thick

NOTE — The contact face of the disc is to be flat.

FIG. 104 PROBE FOR MEASURING SURFACE TEMPERATURES

If the oven can be used for grilling and the instructions state that for grilling the door should be closed, the test is repeated but with the oven operating in the grilling mode with the controls set according to the instructions. The grill is operated for 30 min in accordance with **11.7.103**. However, if the oven has a rotating spit, the duration of the test is 60 min, with the controls set to give the most unfavourable conditions specified in the instructions. The measurements are only carried out on surfaces for which temperature rises for the front surface of oven doors apply.

12 VOID

13 LEAKAGE CURRENT AND ELECTRIC STRENGTH AT OPERATING TEMPERATURE

This clause of Part 1 is applicable except as follows:

13.1 Addition

If a grill is incorporated in the oven, either the oven or the grill is operated, whichever is more unfavourable.

For hobs, the tests are carried out with a vessel filled as specified in **3.1.9.101** placed on each cooking zone.

Induction hob elements are tested as specified for motor-operated appliances.

13.2 Modification

After the appliance has been operated for the duration specified in **11.7**, the controls are adjusted to their highest setting and the leakage current is measured within 10 s of it attaining its highest value.

For stationary class I appliances, the leakage current shall not exceed the following values:

- a) For appliances with heating elements that are detachable or can be switched off separately 1 mA, or 1 mA kW power input for each element with a limit of 10 mA, whichever is higher. If the appliance has more than three heating units, only 75 percent of the measured leakage current is taken into account
- b) For other appliances 1 mA, or 1 mA per kW rated power input with a limit of 10 mA, whichever is higher

If there is earthed metal between live parts and the surface of glass-ceramic or similar material of hobs, the leakage current is measured between live parts and each vessel in turn connected to the earthed metal. If there is no earthed metal, the leakage current, measured between live parts and each of the vessels in turn, shall not exceed 0.25 mA.

13.3 Addition

If there is earthed metal between live parts and the surface of glass-ceramic or similar material of hobs, a test voltage of 1 000 V is applied between live parts and all the vessels connected to the earthed metal. If there is no earthed metal, a test voltage of 3 000 V is applied between live parts and the vessels.

14 TRANSIENT OVERVOLTAGES

This clause of Part 1 is applicable.

15 MOISTURE RESISTANCE

This clause of Part 1 is applicable except as follows:

15.2 Addition

Cooking ranges and hobs are positioned so that the hob surface is horizontal. A vessel having the largest diameter shown in Fig. 101, which does not exceed the diameter of the cooking zone, is completely filled with water containing approximately 1 percent sodium chloride (NaCl) and positioned centrally over the cooking zone. A further quantity of 0.5 litre of the solution is poured steadily into the vessel over a period of 15 s. The test is carried out on each cooking zone in turn, after removing any residual solution from the appliance.

For hob elements incorporating a switch or a thermal control, 0.02 litre of the saline solution is poured over the hob element so that it flows over the switch or control. A vessel is then placed on the hob element to depress any movable part. If controls are mounted below the hob surface, 0.5 litre of the saline solution is poured steadily over the top of the hob near the controls over a period of 15 s. If the controls are mounted in the hob surface, the saline solution is poured over them.

For hobs having ventilating openings in the hob surface, 0.2 litre of the saline solution is poured steadily through a funnel onto the ventilating openings. The funnel has an outlet diameter of 8 mm and is positioned vertically with the outlet 200 mm above the hob surface. The funnel is positioned above the ventilating openings so that the solution enters the appliance in the most unfavourable way.

NOTE 101 — If the opening is protected, the funnel is positioned so that the solution falls onto the hob surface as close as possible to the opening.

NOTE 102 — Care is to be taken to ensure that the saline solution is not poured over controls located close to ventilating openings.

For ovens and grills, 0.5 litre of the saline solution is

poured over the floor of the oven or grilling compartment.

For appliances having a drip tray or similar receptacle, the receptacle is filled with the saline solution. A further quantity of the solution, equal to 0.01 litre per 100 cm² of the area of the top surface of the receptacle, is poured onto the receptacle through openings in the hob surface. However, the total quantity of solution shall not exceed 3 litres.

For hobs having a lid, 0.5 litre of the saline solution is poured uniformly over the closed lid. When the solution has run off, the surface is dried and a further 0.125 litre of the solution is poured steadily from a height of approximately 50 mm onto the centre of the lid over a period of 15 s. The lid is then opened as in normal use.

Steam generators intended to be connected to the water mains are supplied at rated water pressure. Control devices for the supply of water are held open. Water is allowed to flow for 1 min after the first evidence of overflow, unless the inflow stops automatically.

NOTE 103 — Only one device is held open at a time.

15.101 Temperature-sensing probes shall be constructed so that their insulation is not affected by water.

Compliance is checked by the following test.

The probe is completely immersed in water containing approximately 1 percent NaCl and having a temperature of 25°C ± 5°C. The water is heated to the boiling point in approximately 15 min. The probe is then removed from the boiling water and immersed in water having a temperature of 25°C ± 5°C for 30 min.

This procedure is carried out five times after which the probe is removed from the water. All traces of liquid are then removed from the surface.

The probe shall then withstand the leakage current test of 16.2.

NOTE — Detachable temperature-sensing probes are not connected to the appliance for this test. Non-detachable temperature-sensing probes are tested in the oven, the probe being immersed as much as possible.

16 LEAKAGE CURRENT AND ELECTRIC STRENGTH

This clause of Part 1 is applicable except as follows:

16.1 Addition

For hobs, the tests are carried out with a vessel filled as specified in 3.1.9.101 placed on each cooking zone.

Induction hob elements are tested as specified for motor-operated appliances.

16.2 Modification

For stationary class I appliances, the leakage current shall not exceed the following values:

- a) For appliances with heating elements that are detachable or can be switched off separately, 1 mA, or 1 mA per kW with heating power input for each element with a limit of 10 mA, whichever is higher if the appliance has more than three heating units, only 75 percent of the measured leakage current is taken into account
- b) For other appliances 1 mA, or 1 mA per kW rated power input with a maximum of 10 mA, whichever is higher

NOTE 101 — If the oven incorporates a grill, or if the appliance incorporates a means to limit the total power input, only the leakage current of those elements that can be switched on at the same time is taken into consideration.

If there is earthed metal between live parts and the surface of glass-ceramic or similar material of hobs, the leakage current is measured between live parts and each vessel in turn connected to the earthed metal. If there is no earthed metal, the leakage current, measured between live parts and each of the vessels in turn, shall not exceed 0.25 mA.

16.3 Addition

If there is earthed metal between live parts and the surface of glass-ceramic or similar material of hobs, a test voltage of 1 250 V is applied between live parts and all the vessels connected to the earthed metal. If there is no earthed metal, a test voltage of 3 000 V is applied between live parts and the vessels.

17 OVERLOAD PROTECTION OF TRANSFORMERS AND ASSOCIATED CIRCUITS

This clause of Part 1 is applicable.

18 ENDURANCE

This clause of Part 1 is not applicable.

19 ABNORMAL OPERATION

This clause of Part 1 is applicable except as follows.

19.1 Addition

For induction hobs, compliance is also checked by the tests of 19.101 and 19.102, but 19.4 is not applicable.

Temperature-sensing probes are placed in the oven in any position likely to occur during normal use except

that they are not connected to control the oven temperature.

19.2 Addition

Hob elements are operated without a vessel, pan detectors being rendered inoperative. Oven doors are open or closed, whichever is more unfavourable. Hob lids are closed unless the hob elements are interlocked with the lid or an indicator lamp shows that a hob element is switched on.

NOTE 101 — A lamp that is switched on and off by a thermostat or energy regulator does not show that the hob element is switched on.

For appliances incorporating more than one heating unit, the test is only carried out with the heating unit resulting in the most unfavourable conditions, its control being adjusted to the highest setting. If the appliance incorporates an oven without an indicator lamp to show that the oven is switched on, the oven is also operated, its control being adjusted to the highest setting.

NOTE 102 — A lamp used for illuminating the oven, visible through the door and which is automatically switched on and off together with the oven, is considered to be an indicator lamp.

If an induction hob element has a metallic lid, a force of 30 N is applied to the closed lid in the most unfavourable place by means of test probe B of IS 1401.

Pyrolytic self-cleaning ovens are also operated under cleaning conditions, motors that operate during cleaning being switched off or disconnected in turn.

NOTE 103 — Examples are motors of fans and timers.

Induction hob elements are operated under the conditions of 11 but with empty vessels, the controls being adjusted to the highest setting.

Steam ovens are operated without water.

Doors of separate grill compartments incorporated in a cooking range are open or closed, whichever is more unfavourable.

19.9 Not applicable

19.11.2 Addition

During simulation of the fault conditions, it shall be possible to switch off any energized hob element.

The fault conditions are also simulated with all hob elements switched off, the appliance being supplied at rated voltage. If a pan detector is incorporated, a suitable vessel is placed on the cooking zone.

The hob elements shall not become energized.

19.13 Addition

The temperature rise limit of 150 K also applies to wooden cabinets and rectangular boxes.

The temperature in the centre of pyrolytic self-cleaning ovens during the test of 19.4 shall not exceed 425 °C whenever the oven door can be opened.

The temperature rise of the windings of induction hob elements shall not exceed the values specified in 19.7.

The electric strength test of induction hob elements is carried out immediately after switching off the appliance.

Glass in oven doors shall not be damaged.

19.101 Induction hob elements are supplied at rated voltage and operated with a steel disc placed on the centre of the cooking zone. The disc has a thickness of 6 mm and the smallest diameter, rounded up to the nearest centimetre that allows the hob element to operate.

19.102 Induction hob elements are supplied at rated voltage and operated under normal operation but with thermal controls short-circuited.

The temperature rise of the oil shall not exceed 270 K.

20 STABILITY AND MECHANICAL HAZARDS

This clause of Part 1 is applicable except as follows:

20.101 Cooking ranges and ovens shall have adequate stability when the open door is subjected to a load.

Compliance is checked by the following test.

Appliances with horizontally hinged doors are placed on a horizontal surface and a mass is placed on the centre of the open door. For non-rectangular doors, the mass is placed on the part farthest from the hinge where it could be placed in normal use.

For appliances normally placed on the floor the mass is:

- a) 22.5 kg, for oven doors; and
- b) 7 kg, for other doors.

For appliances normally placed on a table, the mass is 7 kg.

For appliances normally placed on the floor and having vertically hinged doors, a mass of 15 kg is placed in the most unfavourable position on the open door.

NOTE 1 — The oven shelves are placed in the most unfavourable position.

NOTE 2 — A sandbag may be used for the load.

NOTE 3 — For an appliance having more than one door, the test is carried out on each door separately.

For cooking ranges incorporating a storage compartment adjacent to the oven and in which the shelves are pulled out simultaneously, the shelves are also loaded. The shelves are placed in the most unfavourable position and loaded with a uniformly distributed mass. The mass, in grams, is equal to the area of the shelf in square centimetres multiplied by:

- a) 7.5, if the free height above the shelf does not exceed 20 cm; and
- b) 15, if the free height above the shelf exceeds 20 cm.

The appliance shall not tilt.

NOTE 4 — Damage and deformation of doors and hinges are neglected.

21 MECHANICAL STRENGTH

This clause of Part 1 is applicable except as follows:

21.1 Addition

If the appliance has glass doors, three blows are applied to the centre of the glass, the door being in the closed position. If the door has horizontal hinges, the blows are also applied to the inside of the door when it is in the open position.

The glass shall not fracture.

If the appliance incorporates visibly glowing heating elements enclosed in glass tubes, the blows are applied to the tubes as mounted in the appliance if they are:

- a) located at the top of the oven and accessible to test probe 41 of IS 1401, and
- b) located elsewhere in the oven and accessible to test probe B of IS 1401.

For hob surfaces of glass-ceramic or similar material, three blows are applied to parts of the surfaces that are not exposed to impacts during the test of **21.102**, the impact energy being increased to $0.70 \text{ J} \pm 0.05 \text{ J}$. The blows are not applied to surfaces within 20 mm of knobs.

NOTE 101 — If the hob surface comprises a single piece of material except for the outer frame, this test is not carried out.

NOTE 102 — Additional support is not provided for the door in the open position.

After the test, temperature-sensing probes are subjected to one cycle of the procedure described in **15.101** and shall then withstand the leakage current test of **16.2**.

21.101 Oven shelves and their supports shall have adequate mechanical strength.

Compliance is checked by the following test.

A vessel filled with sand or shot is placed on the oven shelf. The total mass, in kilograms, is equal to 220 times

the volume of the useful oven space in cubic metres, or 24 kg, whichever is less.

The shelf, with the vessel placed centrally on it, is inserted into the oven and moved as close as possible to one of the side walls. It is left in this position for 1 min and then withdrawn. It is then reinserted, moved as close as possible to the other side wall and left for 1 min.

The test is repeated for each supporting position of the shelf. The shelf and supports shall show no distortion impairing their further use and the shelf shall not fall from the supports.

21.102 Hob surfaces of glass-ceramic or similar material shall withstand the stresses liable to occur in normal use.

Compliance is checked by the following test.

Each hob element is operated at rated power input with its control adjusted to the maximum setting. Induction hob elements are operated as specified in **11**. When steady conditions are established, the hob element is switched off and a loaded vessel is dropped flat 10 times from a height of 150 mm onto the cooking zone.

The vessel has a flat copper or aluminium base over a diameter of $120 \text{ mm} \pm 10 \text{ mm}$, its edges being rounded with a radius of at least 10 mm. It is uniformly filled with at least 1.3 kg of sand or shot so that the total mass is $1.80 \text{ kg} \pm 0.01 \text{ kg}$.

After subjecting each cooking zone in turn to this impact, the vessel is removed and all hob elements are operated simultaneously until steady conditions are established.

A quantity of $1^{+0.1}_0$ litre of water having a temperature of $20^\circ\text{C} \pm 5^\circ\text{C}$ and containing approximately 1 percent NaCl is poured steadily over the hob surface. The appliance is then disconnected from the supply. After 15 min all excess water is removed and the appliance allowed to cool to approximately room temperature. The same quantity of the saline solution is poured over the hob surface after which excess water is removed again.

The hob surface shall not crack and the appliance shall withstand the electric strength test of **16.3**.

21.103 Temperature-sensing probes shall be constructed so that they are not damaged when trapped in the oven door.

Compliance is checked by the following test.

The probe is connected as in normal use and the sensing part or cord allowed to rest in any position likely to occur. The oven door is closed against the sensing part

or cord and a force of 90 N is applied to the door in the most unfavourable place for 5 s.

The probe shall then comply with **8.1**, **15.101** and **29**.

NOTE — The oven is not operated during this test.

21.104 Glass panels of horizontally hinged oven doors shall withstand the thermal shock liable to occur in normal use.

Compliance is checked by the following test.

The appliance is operated as specified in **11**. The door is then opened and 0.2 l of water having a temperature of $20^{\circ}\text{C} \pm 5^{\circ}\text{C}$ is poured within 5 s onto the centre of the glass panel.

The glass shall not fracture.

NOTE — The test is not carried out after the cleaning cycle of pyrolytic self-cleaning ovens.

22 CONSTRUCTION

This clause of Part 1 is applicable except as follows:

22.21 Addition

NOTE **101** — Magnesium oxide and mineral ceramic fibres used for the electrical insulation of heating elements are not considered to be hygroscopic materials.

22.101 Hobs shall be constructed so that hob elements are prevented from rotating about a vertical axis and are adequately supported in all positions of adjustment of their supports.

NOTE — If a hob element is clamped by a nut on a central stud, an additional means is required to prevent its rotation.

Hobs with detachable hob elements shall be constructed so that damage is unlikely to occur while the hob elements are being removed or replaced.

Compliance is checked by inspection.

22.102 Timers intended to delay the operation of a heating element shall not control a radiant grill, unless the grill is thermally controlled and incorporated in an oven or other compartment.

Compliance is checked by inspection.

22.103 Oven vents shall be constructed so that any moisture or grease discharged through them cannot affect clearances and creepage distances between live parts and other parts of the appliance.

Compliance is checked by inspection.

22.104 Steam ovens shall be constructed so that steam vents and ducts are unlikely to become blocked during normal use.

Compliance is checked by inspection.

22.105 Built-in ovens shall only be vented through the

front, unless provision is made for venting through a duct.

Compliance is checked by inspection.

22.106 Grills shall be constructed so that grill pans can be easily positioned without jamming.

The grill pans shall not fall from the support when moved sideways.

Compliance is checked by inspection and by manual test.

22.107 Pyrolytic self-cleaning ovens shall switch off automatically at the end of the cleaning process and require a manual operation to start another cleaning cycle.

Compliance is checked by inspection.

22.108 Pyrolytic self-cleaning ovens shall be constructed so that opening and closing of the door does not impair the interlock system or damage the door seal.

Compliance is checked by the following test.

The door is opened at least 10 cm and is then closed by applying a force of 90 N to the handle. This operation is carried out 5 000 times. Every 1 000 cycles, the interlock system for the self-cleaning function is operated.

After the test, the interlock system shall be fit for further use and the door seal shall not be damaged.

22.109 Pyrolytic self-cleaning ovens shall incorporate an interlock so that access to the oven cannot be gained when the temperature in the centre of the oven exceeds 350°C , even if the interlock is defective.

Compliance is checked by inspection and by the following test.

The oven is supplied at rated voltage and operated under cleaning conditions, after which it is allowed to cool. While the temperature in the centre of the oven exceeds 350°C , a force of 90 N is applied to levers and handles, and a torque of 2 Nm is applied to rotary knobs. It shall not be possible to open the door.

The test is repeated with any defect that may be expected in normal use applied to the interlock system, including interruption of the supply, only one defect being simulated at a time.

NOTE **1** — Examples of defects are the breakage of a spring, or a gravity-operated part failing to drop into position.

NOTE **2** — Fault conditions applied during the tests of **19** are not repeated.

22.110 Pyrolytic self-cleaning ovens shall be

constructed so that ignitable gases cannot be discharged through vents during the cleaning process.

Compliance is checked by the following test.

A mixture of 30 g of gravy and 15 g of hydrogenated oil shortening is spread evenly over the interior of the oven, including the door. The oven is operated for 3 h at the maximum setting of the thermostat.

NOTE 1 — The gravy consists of two-thirds by mass of beef extract and one-third water.

The oven is then operated under cleaning conditions and attempts are made to ignite gases that may be discharged through vents by bursts of sparks. The sparks are approximately 3 mm long, each spark having an energy of at least 0.5 J.

The sparks are applied when the temperature in the centre of the oven reaches 300°C and at each subsequent temperature rise of 50 K.

NOTE 2 — The electrodes used to produce the sparks are moved in and around the vents through which gases may be discharged.

There shall be no continuous burning of gases.

If the oven incorporates a heating element intended to eliminate smoke, the test is repeated with this heating element disconnected if the temperature in the centre of the oven exceeds 450°C under cleaning conditions.

22.111 Pyrolytic self-cleaning ovens shall be constructed so that there is no risk of emission of flames during the cleaning process.

Compliance is checked by the following test.

A suitable vessel containing 100 g of salt-free butter is placed on the centre of the oven floor.

The electrodes of a spark generator are positioned approximately 7.5 cm above the surface of the butter.

The oven is then operated under cleaning conditions and bursts of sparks are produced. The sparks are approximately 3 mm long, each spark having an energy of at least 0.5 J. The sparks are generated when the temperature in the centre of the oven reaches 300°C and at each subsequent temperature rise of 50 K.

There shall be no emission of flames through door seals, vents or other openings.

22.112 Hobs shall be constructed so that hinged lids cannot close accidentally.

Compliance is checked by inspection and by manual test.

NOTE — This requirement may be met if the hinge incorporates a click stop or similar means, or if the lid can be opened through an angle of at least 100°C, when the appliance is placed against a wall.

22.113 Hobs shall be constructed so that inadvertent operation of touch controls is unlikely if this could give rise to a hazardous situation due to:

- a) spillage of liquids, including that caused by vessel boiling over; and
- b) a damp cloth placed on the control panel.

Compliance is checked by the following test, the appliance being supplied at rated voltage. The test is carried out with each hob element energized in turn and then without energizing any hob elements.

Sufficient water to completely cover the control panel to a depth not exceeding 2 mm, with a minimum of 140 ml, is poured steadily over the control panel so that bridging occurs between combinations of touch pads.

A cloth having a mass between 140 g/m² and 170 g/m², and dimensions approximately 400 mm × 400 mm, is folded four times into a square pad, saturated with water and placed over the control panel in any position.

There shall be no operation of any hob element for longer than 10 s.

During the test, it shall be possible to switch off the energized hob element by operating the touch controls, unless it switches off automatically.

22.114 Hobs having touch controls shall require at least two manual operations to switch on a hob element but only one operation to switch it off. However, additional hob elements may be switched on by a single manual operation. In this case, 1 min after all the hob elements have been switched off, two manual operations are required to re-energize one hob element.

NOTE — Touching the contact surface at the same point twice is not considered to be two operations.

Hobs having touch controls shall incorporate visual means to indicate when each hob element is energized.

Compliance is checked by inspection and by manual test.

22.115 Induction hob elements, and other hob elements incorporating a pan detector, shall be constructed so that the hob element can only be operated when a vessel is placed on the cooking zone.

Compliance is checked by the following test, the appliance being supplied at rated voltage.

An iron bar 2 mm thick, having dimensions approximately 100 mm × 20 mm is placed in the most unfavourable position on each cooking zone in turn. The controls are adjusted to their highest setting.

For induction hob elements, the temperature rise of the bar shall not exceed 35 K. Other hob elements shall not operate.

22.116 Hob elements incorporating a pan detector shall be constructed so that the hob element is not switched on by the vessel if it has been removed for more than 10 min.

Compliance is checked by manual test.

22.117 In appliances incorporating a pan detector, a signal lamp shall indicate when the control for the hob element is not switched to the off position.

Compliance is checked by inspection.

22.118 It shall not be possible to operate a grill while the plug of a supply cord is engaged in a socket-outlet located directly above the door.

Compliance is checked by inspection and by manual test.

22.119 Cooking ranges incorporating a retractable deflector to prevent excessive temperatures on control knobs shall be constructed so that the user is unlikely to touch hot surfaces of the deflector when operating the controls.

Compliance is checked by measuring the distance between the deflector in its extended position and that part of the control knob touched in normal use. It shall be at least 25 mm, or the temperature rise of those parts within 25 mm of the knob shall not exceed the limits for handles, knobs, grips and similar parts held for short periods only, as specified in Table 3.

22.120 Outer glass panels of oven doors shall be made from glass that breaks into small pieces when it fractures.

Compliance is checked by carrying out the test specified in 8.10 of ISO 15717. There shall be at least 60 pieces in any 50 mm × 50 mm area.

22.121 Outer glass panels of oven doors that are intended to be removed by the user for cleaning shall be constructed so that they cannot be fixed in an incorrect orientation.

Compliance is checked by inspection and by manual test.

23 INTERNAL WIRING

This clause of Part 1 is applicable except as follows:

23.3 Addition

The requirement also applies if parts of a cooking range are folded onto the hob surface, or separated from their normal position, for transportation purposes.

24 COMPONENTS

This clause of Part 1 is applicable except as follows:

24.1.3 Addition

Switches controlling hob elements are subjected to 30 000 cycles of operation.

NOTE — This does not apply to switches having only one closed position.

24.1.4 Addition

- a) Energy regulators
 - 1) for automatic action 100 000
 - 2) for manual action 10 000
- b) Self-resetting thermal cut-outs:
 - 1) for heating elements of glass-ceramic hobs 100 000
 - 2) for heating elements of other hobs 10 000
- c) Thermostats controlling the cleaning process in pyrolytic self-cleaning ovens 3 000

24.101 Thermostats and energy regulators incorporating an off position shall not switch on as a result of variations in ambient temperatures.

Compliance is checked by the following test that is carried out on three samples of the control.

The control, adjusted to the off position, is placed for 2 h in an ambient temperature of -20_{-5}^0 °C, and then at:

- a) t °C, where t is the temperature according to the T-marking; and
- b) 55°C, for controls without a T-marking.

During the test, the off position shall be maintained.

A test voltage of 500 V is applied across the contacts for 1 min. No breakdown shall occur.

24.102 Socket-outlets incorporated in cooking ranges shall be single-phase, incorporate an earthing contact and have a rated current not exceeding 16 A. Both poles shall be protected by fuses or miniature circuit-breakers having a rated current not exceeding the rated current of the socket-outlet. They shall be placed behind a non-detachable cover. However, if the cooking range is intended to be permanently connected to fixed wiring or is fitted with a polarized plug, the neutral pole need not be protected.

Compliance is checked by inspection.

NOTE 1 — The actuating member of miniature circuit-breakers may be accessible.

NOTE 2 — A non-detachable cover is not required if fuses become accessible after opening a drawer or other compartment.

25 SUPPLY CONNECTION AND EXTERNAL FLEXIBLE CORDS

This clause of Part 1 is applicable except as follows:

25.3 Addition

Hobs, built-in ranges and built-in ovens may be connected to the supply mains before the appliance is installed.

25.14 Addition

For temperature-sensing probes, the total number of flexing is 5 000. Probes with circular-section cords are turned through 90° after 2 500 flexings.

26 TERMINALS FOR EXTERNAL CONDUCTORS

This clause of Part 1 is applicable.

27 PROVISION FOR EARTHING

This clause of Part 1 is applicable.

28 SCREWS AND CONNECTIONS

This clause of Part 1 is applicable.

29 CLEARANCES, CREEPAGE DISTANCES AND SOLID INSULATION

This clause of Part 1 is applicable except as follows:

29.2 Addition

The microenvironment is pollution degree 3 unless the insulation is enclosed or located so that it is unlikely to be exposed to pollution during normal use of the appliance.

29.3 Addition

This requirement does not apply to the sheath of a visibly glowing heating element inaccessible to test probe 41 of IS 1401.

30 RESISTANCE TO HEAT AND FIRE

This clause of Part 1 is applicable except as follows:

30.2 Addition

For grills and griddles that do not incorporate a timer, **30.2.2** is applicable. For other appliances, **30.2.3** is applicable.

31 RESISTANCE TO RUSTING

This clause of Part 1 is applicable.

32 RADIATION, TOXICITY AND SIMILAR HAZARDS

This clause of Part 1 is applicable except as follows:

32.101 Pyrolytic self-cleaning ovens shall be constructed so that carbon monoxide is not discharged in hazardous quantities during cleaning.

Compliance is checked by the following test.

Twice the quantity of the mixture specified in **22.110** is spread evenly over the interior of the oven, including the door. The oven is supplied at rated voltage and operated for 3 h at the maximum setting of the thermostat.

The oven is then allowed to cool to room temperature and placed in a closed test room having a volume of 20 m³ to 25 m³, in which the air is circulated by a low-speed fan. The oven is operated under cleaning conditions and the concentration of carbon monoxide is measured 1 m above the centre of the floor.

The concentration of carbon monoxide shall not exceed 0.015 percent.

If the oven incorporates a heating element intended to eliminate smoke, the test is repeated with this heating element disconnected, unless the cleaning process can only be performed when the heating element is in circuit.

101 TESTS**101.1 Type Tests**

The tests specified in Table 103 shall constitute the type tests and shall be carried out on a sample selected preferably at random from regular production lot (*see 5.3*). Before commencement of the tests, the irons shall be visually examined and inspected of components, parts and their assembly, constructions, mechanical hazards, marking provision of suitable terminals for supply connections, earthing and the effectiveness screws and connection. The external surface finish shall be even and free from finishing defects.

101.1.1 Criteria of Acceptance

Sample shall successfully pass all the type tests for proving conformity with the requirements of the standard. If the sample fails in any of the type tests, the testing authority, at its discretion, may call for fresh samples not exceeding twice the original number and subject them again to all tests or to the test(s) in

which failure(s) had occurred. No failure should be permitted in the repeat test(s).

Table 103 Schedule of Type Tests
(Clause 101.1)

Sl No.	Tests	Clause Reference
(1)	(2)	(3)
i)	Protection against access to live parts	8
ii)	Power input and current	10
iii)	Heating	11
iv)	Leakage current and electric strength at operating temperature	13
v)	Transient overvoltages	14
vi)	Moisture resistance	15
vii)	Leakage current and electric strength	16
viii)	Overload protection of transformers and associated circuits	17
ix)	Abnormal operation	19
x)	Stability and mechanical hazards	20
xi)	Mechanical strength	21
xii)	Construction	22
xiii)	Internal wiring	23
xiv)	Components	24
xv)	Supply connection and external flexible cords	25
xvi)	Terminals for external conductors	26
xvii)	Provision for earthing	27
xviii)	Screws and connections	28
xix)	Clearances, creepage distances and solid insulation	29
xx)	Resistance to heat and fire	30
xxi)	Resistance to rusting	31
xxii)	Radiation, toxicity and similar hazards	32

101.2 Acceptance Tests

The following shall constitute the acceptance tests:

Test	Clause Reference
(1)	(2)
a) Protection against access to live parts	8
b) Power input and current	10
c) Heating	11
d) Leakage current and electric strength at operating temperature	13
e) Moisture resistance	15
f) Leakage current and electric strength	16
g) Provision for earthing	27

NOTE — For the purpose of acceptance tests, the humidity treatment shall be done for 24 h while conducting the test for moisture resistance (15).

101.2.1 A recommended sampling procedure for acceptance tests is given in Annex J of IS 302-1.

101.3 Routine Tests

The following shall constitute the routine tests:

Test	Clause Reference
(1)	(2)
a) Protection against access to live parts	8
b) High voltage	13.3.2 of IS 302-1
c) Provision for earthing	27

ANNEXES

The Annexes of Part 1 are applicable.

Bureau of Indian Standards

BIS is a statutory institution established under the *Bureau of Indian Standards Act, 1986* to promote harmonious development of the activities of standardization, marking and quality certification of goods and attending to connected matters in the country.

Copyright

BIS has the copyright of all its publications. No part of these publications may be reproduced in any form without the prior permission in writing of BIS. This does not preclude the free use, in the course of implementing the standard, of necessary details, such as symbols and sizes, type or grade designations. Enquiries relating to copyright be addressed to the Director (Publications), BIS.

Review of Indian Standards

Amendments are issued to standards as the need arises on the basis of comments. Standards are also reviewed periodically; a standard along with amendments is reaffirmed when such review indicates that no changes are needed; if the review indicates that changes are needed, it is taken up for revision. Users of Indian Standards should ascertain that they are in possession of the latest amendments or edition by referring to the latest issue of 'BIS Catalogue' and 'Standards : Monthly Additions'.

This Indian Standard has been developed from Doc No.: ETD 32 (5972).

Amendments Issued Since Publication

Amend No.	Date of Issue	Text Affected

BUREAU OF INDIAN STANDARDS

Headquarters:

Manak Bhavan, 9 Bahadur Shah Zafar Marg, New Delhi 110002
Telephones : 2323 0131, 2323 3375, 2323 9402 Website: www.bis.org.in

Regional Offices:

	Telephones
Central : Manak Bhavan, 9 Bahadur Shah Zafar Marg NEW DELHI 110002	{ 2323 7617 2323 3841
Eastern : 1/14 C.I.T. Scheme VII M, V. I. P. Road, Kankurgachi KOLKATA 700054	{ 2337 8499, 2337 8561 2337 8626, 2337 9120
Northern : SCO 335-336, Sector 34-A, CHANDIGARH 160022	{ 60 3843 60 9285
Southern : C.I.T. Campus, IV Cross Road, CHENNAI 600113	{ 2254 1216, 2254 1442 2254 2519, 2254 2315
Western : Manakalaya, E9 MIDC, Marol, Andheri (East) MUMBAI 400093	{ 2832 9295, 2832 7858 2832 7891, 2832 7892

Branches: AHMEDABAD. BANGALORE. BHOPAL. BHUBANESHWAR. COIMBATORE. DEHRADUN. FARIDABAD. GHAZIABAD. GUWAHATI. HYDERABAD. JAIPUR. KANPUR. LUCKNOW. NAGPUR. PARWANOO. PATNA. PUNE. RAJKOT. THIRUVANANTHAPURAM. VISAKHAPATNAM.