

Safety of transportable motor-operated electric tools —

Part 2-4: Particular requirements for bench grinders

The European Standard EN 61029-2-4:2003, with the incorporation of amendment A1:2003, has the status of a British Standard

ICS 25.140.20; 25.080.50

National foreword

This British Standard is the official English language version of EN 61029-2-4:2003, including Corrigendum April 2003 and amendment A1:2003. It was derived by CENELEC from IEC 61029-2-4:1993.

The common modifications have been implemented by CENELEC and are indicated in the text by a vertical line in the left margin.

The UK participation in its preparation was entrusted by Technical Committee CPL/61, Safety of household and similar electrical appliances, to Subcommittee CPL/61/6, Portable motor-operated tools, which has the responsibility to:

- aid enquirers to understand the text;
- present to the responsible international/European committee any enquiries on the interpretation, or proposals for change, and keep the UK interests informed;
- monitor related international and European developments and promulgate them in the UK.

A list of organizations represented on this subcommittee can be obtained on request to its secretary.

Cross-references

The British Standards which implement international or European publications referred to in this document may be found in the *BSI Catalogue* under the section entitled “International Standards Correspondence Index”, or by using the “Search” facility of the *BSI Electronic Catalogue* or of British Standards Online.

This publication does not purport to include all the necessary provisions of a contract. Users are responsible for its correct application.

Compliance with a British Standard does not of itself confer immunity from legal obligations.

This British Standard was published under the authority of the Standards Policy and Strategy Committee on 4 April 2003

Summary of pages

This document comprises a front cover, an inside front cover, the EN title page, pages 2 to 25 and a back cover.

The BSI copyright notice displayed in this document indicates when the document was last issued.

Amendments issued since publication

Amd. No.	Date	Comments
14502 Corrigendum No. 1	11 July 2003	Change to subclause 13.2.4
14858	12 January 2004	Incorporation of amendment A1:2003

© BSI 12 January 2004

ISBN 0 580 41508 2

<http://www.china-gauges.com/>

EUROPEAN STANDARD

NORME EUROPÉENNE

EUROPÄISCHE NORM

EN 61029-2-4

January 2003

+ A1

September 2003

ICS 25.140.20; 25.080.50

English version

Safety of transportable motor-operated electric tools
Part 2-4: Particular requirements for bench grinders
(including amendment A1:2003)
(IEC 61029-2-4:1993, modified)

Sécurité des machines-outils
électriques semi-fixes
Partie 2-4: Règles particulières
pour les tourets à meuler
(inclut l'amendement A1:2003)
(CEI 61029-2-4:1993, modifiée)

Sicherheit transportabler
motorbetriebener Elektrowerkzeuge
Teil 2-4: Besondere Anforderungen
für Tischschleifmaschinen
(enthält Änderung A1:2003)
(IEC 61029-2-4:1993, modifiziert)

This European Standard was approved by CENELEC on 2002-03-05. Amendment A1 was approved by CENELEC on 2003-03-01. CENELEC members are bound to comply with the CEN/CENELEC Internal Regulations which stipulate the conditions for giving this European Standard the status of a national standard without any alteration.

Up-to-date lists and bibliographical references concerning such national standards may be obtained on application to the Central Secretariat or to any CENELEC member.

This European Standard exists in three official versions (English, French, German). A version in any other language made by translation under the responsibility of a CENELEC member into its own language and notified to the Central Secretariat has the same status as the official versions.

CENELEC members are the national electrotechnical committees of Austria, Belgium, Czech Republic, Denmark, Finland, France, Germany, Greece, Hungary, Iceland, Ireland, Italy, Lithuania, Luxembourg, Malta, Netherlands, Norway, Portugal, Slovakia, Spain, Sweden, Switzerland and United Kingdom.

CENELEC

European Committee for Electrotechnical Standardization
Comité Européen de Normalisation Electrotechnique
Europäisches Komitee für Elektrotechnische Normung

Central Secretariat: rue de Stassart 35, B - 1050 Brussels

© 2003 CENELEC - All rights of exploitation in any form and by any means reserved worldwide for CENELEC members.

Ref. No. EN 61029-2-4:2003 + A1:2003 E

<http://www.china-gauges.com/>

Foreword

The text of the International Standard IEC 61029-2-4:1993, prepared by SC 61F, Safety of hand-held motor-operated electric tools, of IEC TC 61, Safety of household and similar electrical appliances, together with the common modifications prepared by the Technical Committee CENELEC TC 61F, Safety of hand-held and transportable electric motor-operated tools, was submitted to the Unique Acceptance Procedure and was approved by CENELEC as EN 61029-2-4 on 2002-03-05.

A draft for an amendment (prAA) was submitted to the formal vote and was approved by CENELEC for incorporation into EN 61029-2-4 on 2002-03-05.

The following dates were fixed:

- latest date by which the EN has to be implemented at national level by publication of an identical national standard or by endorsement (dop) 2003-08-01
- latest date by which the national standards conflicting with the EN have to be withdrawn (dow) 2005-03-01

In this document the common modifications to the International Standard are indicated by a vertical line in the left margin of the text.

This European Standard is divided into two parts:

Part 1 General requirements which are common to most transportable electric motor operated tools (for the purpose of this standard refer

red to simply as tools) which could come within the scope of this standard;

Part 2 Requirements for particular types of tool which either supplement or modify the requirements given in part 1 to account for the particular hazards and characteristics of these specific tools.

This European Standard has been prepared under a mandate given to CEN/CENELEC by the European Commission and the European Free Trade Association and supports the essential health and safety requirements of the Machinery Directive.

Compliance with the relevant clauses of part 1 together with this part 2 provides one means of conforming with the specified essential health and safety requirements of the Directive.

For noise and vibration this standard covers the requirements for their measurement, the provision of information arising from these measurements and the provision of information about the personal protective equipment required. Specific requirements for the reduction of the risk arising from noise and vibration through the design of the tool are not given as this reflects the current state of the art.

As with any standard, technical progress will be kept under review so that any developments can be taken into account.

Warning: Other requirements and other EC Directives can be applicable to the products falling within the scope of this standard.

Part 2-4 is to be used in conjunction with EN 61029-1:2000.

Part 2-4 supplements or modifies the corresponding clauses of EN 61029-1, so as to convert it into the European Standard: Safety requirements for transportable bench grinders.

Where a particular subclause of part 1 is not mentioned in this part 2-4, that subclause applies as far as is reasonable. Where this part 2-4 states "addition", "modification" or "replacement", the relevant text of part 1 is to be adapted accordingly.

Subclauses, tables and figures which are additional to those in part 1 are numbered starting from 101. Subclauses, tables and figures which are additional to those in IEC 61029-2-4 are prefixed "Z".

NOTE In this European Standard the following print types are used:
- Requirements proper;
- *Test specifications*;
- Explanatory matter.

Foreword to amendment A1

The text of amendment 1:2001 to the International Standard IEC 61029-2-4:1993, prepared by SC 61F, Safety of hand-held motor-operated electric tools, of IEC TC 61, Safety of household and similar electrical appliances, together with the common modifications prepared by the Technical Committee CENELEC TC 61F, Safety of hand-held and transportable motor-operated electric tools, was submitted to the Unique Acceptance Procedure and was approved by CENELEC as amendment A1 to EN 61029-2-4:2003 on 2003-03-01.

The following dates were fixed:

- latest date by which the amendment has to be implemented at national level by publication of an identical national standard or by endorsement (dop) 2004-04-01
- latest date by which the national standards conflicting with the amendment have to be withdrawn (dow) 2006-03-01

In this document, the common modifications to the International Standard are indicated by a vertical line in the left margin of the text.

Contents

1	Scope	5
2	Definitions	5
3	General requirement	6
4	General notes on tests	6
5	Rating	6
6	Classification	6
7	Marking	6
8	Protection against electric shock	7
9	Starting	7
10	Input and current	7
11	Heating	8
12	Leakage current	8
13	Environmental requirements	8
14	Protection against ingress of foreign bodies and moisture resistance	8
15	Insulation resistance and electric strength	9
16	Endurance	9
17	Abnormal operation	9
18	Stability and mechanical hazards	9
19	Mechanical strength	14
20	Construction	14
21	Internal wiring	15
22	Components	15
23	Supply connection and external flexible cables and cords	15
24	Terminals for external conductors	15
25	Provision for earthing	15
26	Screws and connections	15
27	Creepage distances, clearances and distance through insulation	15
28	Resistance to heat, fire and tracking	15
29	Resistance to rusting	15
30	Radiation	15
	Figures	16
	Annex A (normative) Normative references	25

1 Scope

This clause of part 1 is applicable except as follows:

1.1 *Addition:*

This International Standard applies to transportable bench grinders (Figure 101) and combined bench grinders (Figure 107) with a wheel diameter and brush diameter not exceeding 200 mm and a peripheral speed not exceeding 50 m/s, as defined in 2.101 and 2.114.

The requirements for bonded abrasive products (wheel) are given in EN 12413. The requirements for brushes are given in EN 1083.

2 Definitions

This clause of part 1 is applicable except as follows:

2.21 *Replacement:*

2.21

normal load

the load to obtain rated input

2.101

bench grinder

tool designed to grind metal or similar materials by means of one or two rotating abrasive wheels fixed on the tool spindle, the work piece being held by hand (see Figure 101)

2.102

accessory

device or piece other than a grinding wheel intended to be mounted on the bench grinder spindle

2.103

tool spindle

motor spindle of the bench grinder or of the combined bench grinder which supports the brush and/or grinding wheels and transports the rotation to them

2.104

nozzle for dust collection

device allowing the connection of a bench grinder or a combined bench grinder to a dust collection system

2.105

guard for wheel

device which partially encloses the abrasive wheel in order to protect the user against accidental contact with the wheel in normal use and against ejection of fragments of the wheel in the protected area in case of breakage of the wheel

2.106

flange assembly

means provided to clamp an abrasive wheel to the tool spindle

2.107

work rest

surface or device intended to support or guide the piece to be worked

2.112

working speed

linear peripheral speed of the wheel or of the brush while working

2.114

combined bench grinder

tool designed to grind metal or similar materials or to clean, polish or deburr metal or similar materials by means of an abrasive wheel and a brush fixed on opposite ends of the tool spindle, and which is located in a proper workplace and where pieces are held by hand

3 General requirement

This clause of part 1 is applicable.

4 General notes on tests

This clause of part 1 is applicable.

5 Rating

This clause of part 1 is applicable.

6 Classification

This clause of part 1 is applicable.

7 Marking

This clause of part 1 is applicable except as follows:

7.1 *Addition:*

- the rated no-load speed in rev/min;
- the maximum diameter D of the wheel to be used;
- indication of the direction of rotation of the grinding wheel.
- for combined bench grinders, the maximum diameter D of the brush to be used;
- for combined bench grinders/brushes, a warning near to the brush holder spindle never to use a grinding wheel on the brush side of the machine;
- a warning to wear safety glasses or the relevant symbol.

7.6 *Addition:*

The direction of rotation of the wheel shall be indicated on the tool by an arrow raised or sunk or by any other means not less visible and indelible.

7.13 *Addition:*

The handbook or information sheet shall include all the necessary information for safe working with the bench grinder or combined bench grinder, such as method of operation, wheel and brush changing, maintenance, assembly, transportation, etc.

The substance of the following instructions shall also be given:

- wear protective glasses;
- do not use damaged or misshapen wheels or brushes;
- use only grinding wheels recommended by the manufacturer which have a marked speed equal to or greater than the speed marked on the nameplate of the tool;
- adjust the spark arrestor frequently so as to compensate for wear of the wheel, keep the distance between the spark arrestor and the wheel as small as possible and in any case not greater than 2 mm;
- instruction for the safe use, handling and storage of abrasive wheels taking into account the requirements of the CEN standard for abrasive products for the type of tool covered by this standard. It is assumed that wheels will not be dressed. If wheel dressing is intended then suitable precautions should be taken;
- if the grinder is intended to be bolted down, an instruction requesting it to be secured to a suitable work surface.
- for combined bench grinders, do always keep the brush assembled on the spindle in order to limit the risk of contact with the rotating spindle;

The following information shall also be given:

- how to connect the dust collection device, if any;
- details of the grinding wheel(s) recommended, the maximum thickness of the wheel and the diameter of the hole in the wheel;
- the maximum wear of the wheel allowed before replacement;
- description of residual risks.
- for bench grinders and combined bench grinders equipped with straight-sided flanges, the recommended values of the thickness T and the diameter of the hole.

NOTE Sketches may be used to illustrate the modes of operation.

8 Protection against electric shock

This clause of part 1 is applicable.

9 Starting

This clause of part 1 is applicable.

10 Input and current

This clause of part 1 is applicable.

11 Heating

This clause of part 1 is applicable.

12 Leakage current

This clause of part 1 is applicable.

13 Environmental requirements

This clause of part 1 is applicable except as follows:

13.1 This subclause is not applicable.

13.2.1 Addition:

The most important sources of noise are:

- abrasive wheels,
- workpieces.

13.2.4 Replacement:

Bench grinders are tested under load under the conditions shown in Table Z101.

Table Z101 – Noise test conditions for bench grinders

Wheels	New wheels as recommended by the manufacturer for grinding of firmer chisel
Work piece	Flat firmer chisel, 30 mm wide
Feed-speed	Sufficient to perform finish-grind
Test position	To be used on a test bench above reflecting plane as shown in Figure 12 of part 1.
Test cycle	To consider the influence of different wheels the measurements shall be performed as follows: <ul style="list-style-type: none"> - 3 measurements with grinding wheel; - 3 measurements with finishing wheel. Each measurement shall take at least 60 s.

The highest mean value of the three equivalent measurements has to be given in the manual.

The tool shall be used in such a manner as to correspond to normal use.

13.3 This subclause is not applicable.

14 Protection against ingress of foreign bodies and moisture resistance

This clause of part 1 is applicable.

15 Insulation resistance and electric strength

This clause of part 1 is applicable.

16 Endurance

This clause of part 1 is applicable.

17 Abnormal operation

This clause of part 1 is applicable.

18 Stability and mechanical hazards

This clause of part 1 is applicable except as follows:

18.1 *Addition:*

Bench grinders and combined bench grinders shall be equipped with an adequate guarding system, which cannot be removed without the aid of a tool.

The guarding system shall comply with the requirements of 18.1.101.

18.1.101 Guard for wheel

Bench grinders and combined bench grinders shall be equipped with guards which leave uncovered only a portion of the wheel as allowed in 18.1.101.2 and indicated in Figure 103. Guards shall be designed to have mechanical resistance to accidental breaking of the wheels.

On straight-sided wheels the side guard shall cover the flanges and the end of the tool spindle.

The guard shall be designed so that the tool cannot be fitted with a wheel greater than 1,07 times the maximum diameter marked on the tool.

18.1.101.1 Strength of guards

Guards for straight sided wheels shall either

- a) have a thickness as given in Table Z102 or Table Z103, provided the guard is made of material in accordance with Table Z104, or,
- b) meet the requirements of 18.1.101.1.1.

Guards for cup wheels shall either

- a) have a thickness as given in Table Z102 or Table Z103, provided the guard is made of material in accordance with Table Z104, or,
- b) if the bench grinder is also fitted with a straight sided wheel and that guard meets the requirements of 18.1.101.1.1, be of the same material and thickness as the guard for the straight sided wheel.

Table Z102 - Guard thickness for steel

Material (see Table Z104)	Peripheral speed m/s	Wheel thickness mm	Wheel diameter in mm					
			≤ 125		≤ 200		≤ 250	
			P	J	P	J	P	J
1, 2 & 3	32	50	1,5	1,5	2	1,5	3	2
1, 2 & 3	40	25	1,5	1,5	2	1,5	2,5	2
		50	1,5	1,5	2	1,5	3,5	2
1, 2 & 3	50	25	1,5	1,5	2	1,5	3	2
		50	2	1,5	3	2	4,5	3

Table Z103 - Guard thickness for aluminium

Material (See Table Z104)	Peripheral speed m/s	Wheel thickness mm	Wheel diameter in mm					
			≤ 125		≤ 200		≤ 250	
			P	J	P	J	P	J
7	32	10	5,5	5	6,5	5	8	6
		20	6	5	8	6	10	8
		32	6,5	5	9	7	12	10
	50	10	6	5	8,5	7	10,5	9
		20	7	6	10	8	13	11
6	40	10	2,5	2,5	3,5	3,5	4	4
		20	3	3	4	4	5	5
		32	3,5	3,5	4,5	4,5	6	5
	50	10	3	3	4	4	5	5
		20	3,5	3,5	4,5	4,5	6	5
		32	4	4	5	5	7	6

Table Z104 - Material specifications

Reference No.	Material	ISO or EN	Ultimate tensile strength N/mm ²	Elastic strength N/mm ²	Elongation %
1	Steel	ISO 3574 EN 10130	270	140	28
2	Steel	ISO 4997 ISO 6316	300	220	18
3	Steel	ISO 1052 EN 10025	340	215	17
4	Steel	ISO 3755	450	230	22
6	Aluminium	ISO 6361	310	260	10
7	Aluminium	ISO 3522	200	-	3

18.1.101.1.1 Strength test

The tool shall be assembled as for normal use, the guard shall be equipped with any attachments for which it is designed.

The tool shall be fitted with a grinding wheel of the same dimensions as recommended for normal use and shall be rotating at maximum speed. A projectile shall be made to impact the wheel as close as possible to the flange so as to cause a complete breakage of the wheel, care being taken that the projectile does not itself affect the outcome of the test (see Figure 102).

This test is dangerous and must only be carried out in a properly constructed and equipped test facility. The test must be carried out in a fully protected enclosure which can contain all the wheel fragments and other debris.

Compliance is checked by test and inspection. After the test the wheel guard shall remain attached to the tool, remain effective and shall show no visible crack when examined by a recognised method of crack detection. Minor deformations and superficial damage are acceptable. Any fixing devices such as guard clamps, bolts etc. shall remain effective.

18.1.101.2 Openings in the guard

18.1.101.2.1 For straight-sided wheels the opening angle in the guard shall not exceed 65° above the horizontal plane passing through the centre of the wheel.

Under this plane the opening height H shall be smaller than $0,2 D$ (see Figure 103) but in any case the total opening shall not exceed 90° .

18.1.101.2.2 For straight-sided cup wheels the height of the opening in the guard shall not be greater than $0,4 D$ above the horizontal plane passing through the axis of the wheel (see Figure 104a).

The opening in the guard H , below the horizontal plane passing through the axis of the wheel, shall not be greater than $0,2 D$ (see Figure 104b).

The width of the opening in the guard periphery shall not be more than is sufficient to allow the use of the wheel until it is worn out.

18.1.101.2.3 The side clearance between the wheel and the guard shall be as small as possible.

Compliance with 18.1.101.2 is checked by inspection and measurement.

18.1.101.3 Spark arrestor

Bench grinders and combined bench grinders equipped with straight-sided wheels shall have a spark arrestor to limit the ejection of sparks and pieces of wheel from the wheel guard. Its aim is also to improve the collection of dust.

The spark arrestor shall be situated at the upper part of the wheel guard in line with the periphery of the wheel and cover all the width of the wheel guard.

The spark arrestor shall be adjustable to within 2 mm of the surface of the wheel for all diameters of wheel from the maximum wheel diameter to the minimum recommended by the manufacturer.

Compliance is checked by inspection.

18.1.101.4 Work rest

Bench grinders and combined bench grinders shall be equipped with work rests. This requirement does not apply to the brush side of the combined bench grinder.

The work rest shall be adjustable to within 2 mm of the surface of the wheel for all diameters of wheel from the maximum wheel diameter to the minimum recommended by the manufacturer.

The work rest shall be easy to adjust, shall cover at least the width of the wheel guard and the fixings shall ensure a firm position of the rest.

When the bench grinder and/or the grinder side of the combined bench grinder is fitted with an inclinable work rest, the inclination shall only be possible downwards and the tilting upwards of the work rest shall be made impossible (Figure 105).

Compliance is checked by inspection.

18.1.102 Flange

18.1.102.1 Flange for wheel

Table 101 gives minimal dimensions of flanges made in steel or other material of adequate strength with minimal tensile strength of 430 N/mm² or sintered powder metal with minimal tensile strength of 500 N/mm² in relation to the diameter of the wheel and for a wheel thickness not exceeding 0,15 times the diameter.

Table 101 – Flange dimensions for wheel (see Figure 108)

<i>D</i>	<i>d_f</i>	<i>r</i>	<i>E</i>	<i>F</i>	<i>T</i>
100	34	6	5	3,2	1,5
125	42	8	6	3,2	1,5
150	52	9	10	5	1,5
200	68 ¹⁾	12 ¹⁾	10 ¹⁾	5 ¹⁾	1,5 ¹⁾

1) These values are valid for flanges to be used on wheels with 200 mm nominal diameter and 30 mm thickness.

Cast iron flanges shall not be used.

18.1.102.2 Flange for brush

Table 102 gives minimal dimensions of flanges made in steel or other material of adequate strength with minimal tensile strength of 430 N/mm² or sintered powder metal with minimal tensile strength of 500 N/mm² in relation to the diameter of the brush.

Table 102 – Flange dimensions for brush (see Figure 109)

<i>D</i>	<i>d_f</i>	<i>r</i>	<i>E</i>	<i>F</i>	<i>T</i>
100	34	5	1,5	1,5	1,5
125	42	5	2	2	1,5
150	52	5	2,5	2,5	1,5
200	68	5	2,5	2,5	1,5

| Cast iron flanges shall not be used.

18.1.102.Z3 Torque test for flanges

Flanges which do not fulfil the minimal dimensions or the minimal tensile strength specified in 18.1.102.1.1 and 18.1.102.1.2 shall be checked by the following test:

The abrasive wheel shall be replaced by a steel disc having the same dimensions.

The clamping nut shall be tightened with a first test torque according to Table Z105. A feeler gauge of thickness 0,05 mm shall be used to check whether the flanges are in contact with the disc all around the circumference. It shall not be possible to push the feeler gauge between the flange and the surface of the disc.

The clamping nut shall then be tightened to the second test torque according to Table Z105. It shall not be possible to push the feeler gauge between the flange and the surface of the disc by more than 1 mm at any point around the circumference of the flange.

Table Z105 - Test torque for flanges

Thread		First test torque Nm	Second test torque Nm
Metric	UNC		
8		2	8
10	3/8	4	15
12	1/2	7,5	30
14		11	45
16	5/8	17,5	70
	3/4	35	140

18.1.103 Transparent screens

18.1.103.1 Transparent screen characteristics

The bench grinders and combined bench grinders shall be fitted with transparent screens designed to prevent projection of particles towards the eyes and the face of the operator.

The transparent screens shall be adjustable and of such dimensions that in normal positions of grinding and polishing, including in a vertical plane above the wheel or the brush, the operator shall see the working part of the wheel or of the brush only through the screen.

The operation of adjusting the screen shall not modify the adjustment of other parts of the bench grinder or combined bench grinder.

The screen shall be made of transparent material having an appropriate resistance against shocks and abrasion. Ply glass and polycarbonate are recommended. Other plastic materials used must have an impact and resistance similar to ply glass and polycarbonate.

18.1.103.2 Minimal dimension of the transparent part of rectangular or trapezoidal transparent screens

The minimal dimensions of the transparent part of screens for bench grinders equipped with straight-sided cup wheels are identical to those of screens for bench grinders or combined bench grinders equipped with straight-sided wheels. However, for bench grinders and for the grinder side of the combined bench grinders, the thickness of straight-sided wheels shall be replaced by the width of the working part of the straight-sided cup wheel.

For all bench grinders and combined bench grinders, the screens shall be mounted in such a way that the symmetrical axis of the screen coincides with the vertical median plane of the working part of the wheel or the brush (Figure 106).

18.1.104 Protection of the free extremity of the rotative shaft in the combined bench grinder

The shaft part on the brush side, when not fitted with a brush, shall be protected in order to avoid accidental contacts.

Compliance is checked by applying the test pin in Figure 2 of Part 1.

NOTE A possible solution for satisfying this requirement is shown in Figure 110.

18.2 Addition:

Bench grinders and combined bench grinders shall have provisions to be fixed on a support.

19 Mechanical strength

This clause of part 1 is applicable except as follows:

19.Z101 The wheel guards, including their fixing, shall have adequate mechanical strength to withstand the loading applied during handling.

Compliance is checked by the following test:

The grinder guards have to be supported in such a way that no other parts of the grinder are supported, neither by the supporting means nor by the bench, see Figure Z101.

A vertical downward force equal to the weight of the grinder is applied over the centre of the tool for 1 min.

There shall be no visible deformation of the guard during and after the test.

20 Construction

This clause of part 1 is applicable except as follows:

20.18 Replacement:

Switches shall be so located that accidental operation is unlikely to occur.

Compliance is checked by applying a sphere with a diameter of 100 mm \pm 1 mm to the switch.

It shall not be possible to start the tool by means of the sphere.

20.20 *Addition:*

Bench grinders are not considered to give rise to danger on restoration of the voltage supply.

21 Internal wiring

This clause of part 1 is applicable.

22 Components

This clause of part 1 is applicable.

23 Supply connection and external flexible cables and cords

This clause of part 1 is applicable

24 Terminals for external conductors

This clause of part 1 is applicable.

25 Provision for earthing

This clause of part 1 is applicable.

26 Screws and connections

This clause of part 1 is applicable.

27 Creepage distances, clearances and distance through insulation

This clause of part 1 is applicable.

28 Resistance to heat, fire and tracking

This clause of part 1 is applicable.

29 Resistance to rusting

This clause of part 1 is applicable.

30 Radiation

This clause of part 1 is not applicable.

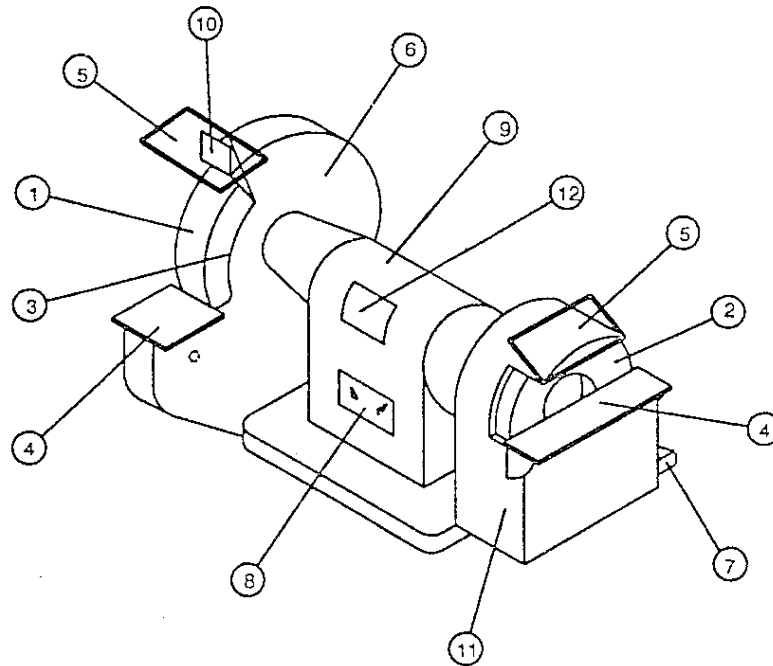

- 1 = straight-sided grinding wheel
- 2 = straight-sided cup wheel
- 3 = flange
- 4 = work rest
- 5 = transparent screen
- 6 = guard for straight-sided wheel

- 7 = nozzle for dust
- 8 = on/off device
- 9 = motor housing
- 10 = spark arrestor
- 11 = cup wheel guard
- 12 = marking plate

Figure 101 – Bench grinder

This drawing is given as a guide only

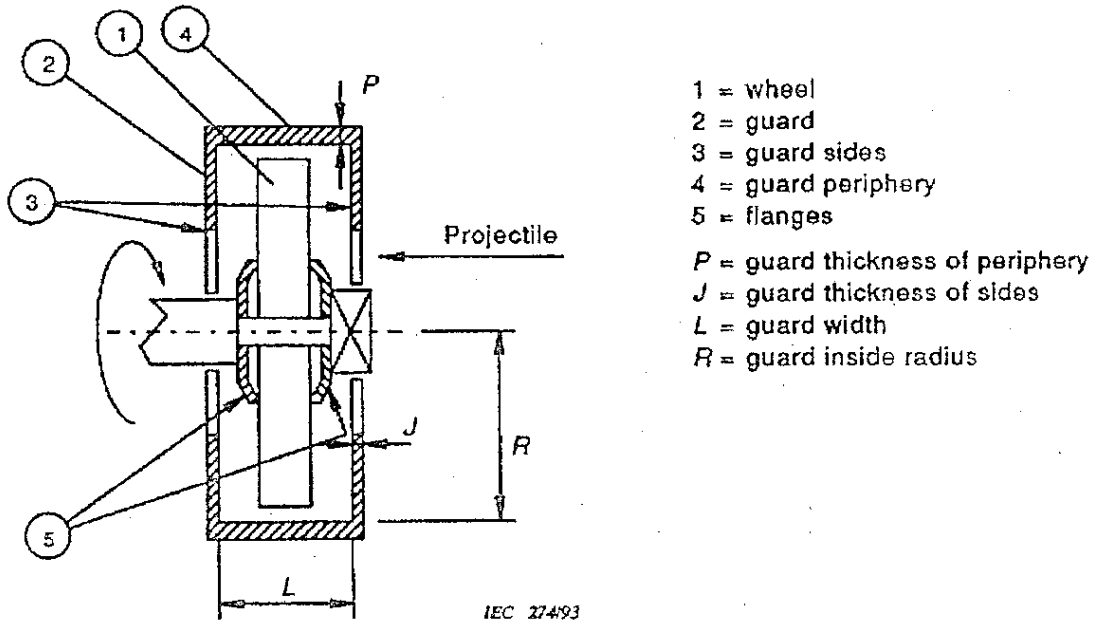
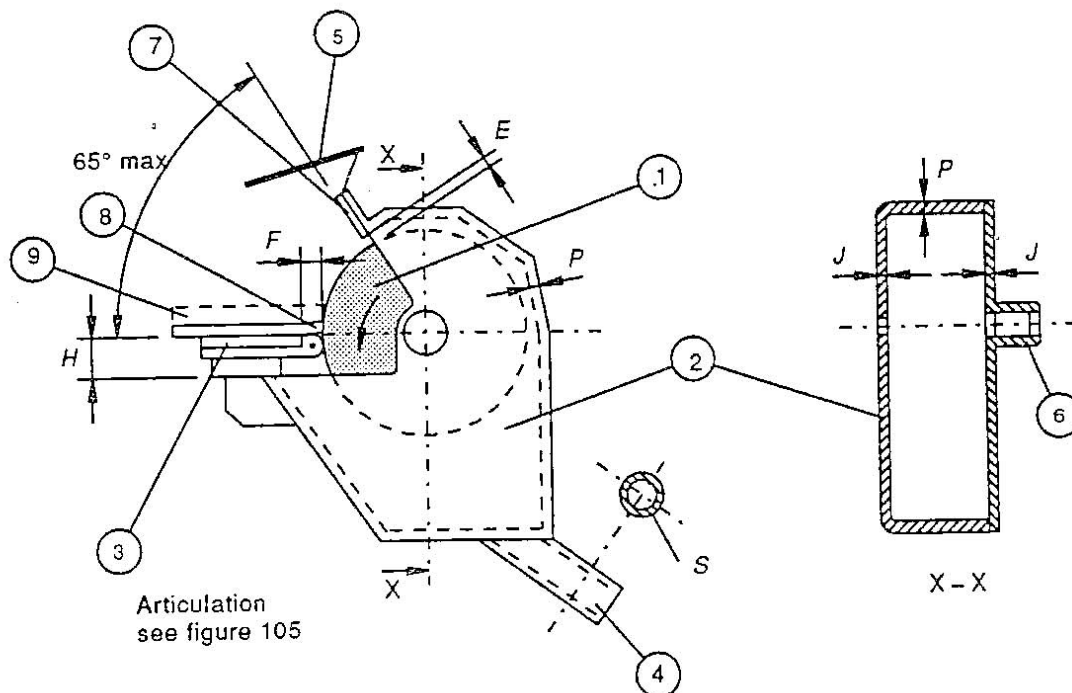

Figure 102 – Schema



- 1 = grinding wheel
 2 = guard of the wheel
 3 = work rest
 4 = nozzle for dust
 5 = transparent screen
 6 = guard for axis
 7 = spark arrestor
 8 = working area of the wheel
 9 = workpiece

- P* = thickness of the periphery of the guard
J = thickness of the sides of the guard
S = internal section of the nozzle
D = maximal external diameter of the wheel
E = clearance between spark arrestor and wheel
F = clearance between work rest and wheel

Figure 103 – Guard

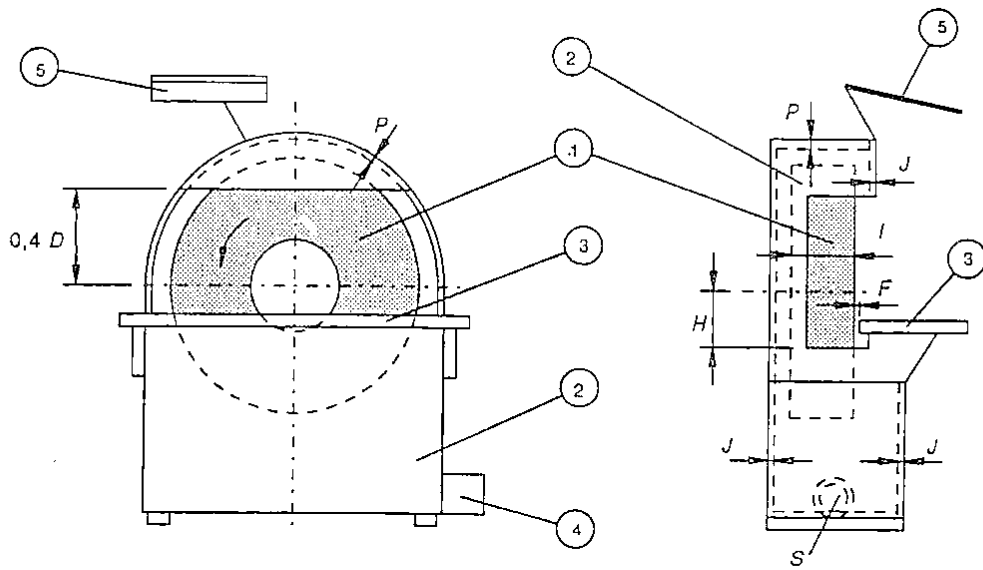

Figure 104a

Figure 104b

- 1 = grinding wheel
- 2 = guard of the wheel
- 3 = work rest
- 4 = nozzle for suction device
- 5 = transparent screen

- P = thickness of the periphery of the guard
- J = thickness of the sides of the guard
- S = internal section of the nozzle
- D = maximal external diameter of the wheel
- F = clearance between work rest and wheel
- I = thickness of the wheel

Figure 104 – Bench grinder equipped with straight-sided cup wheels

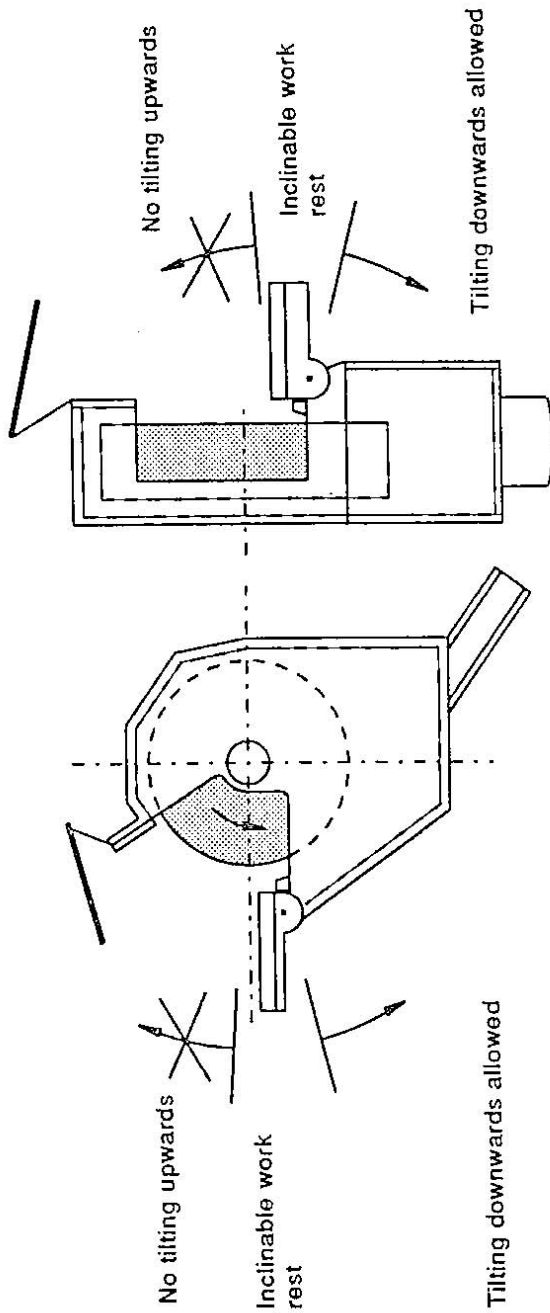

Figure 105 – Bench grinder with inclinable work rest

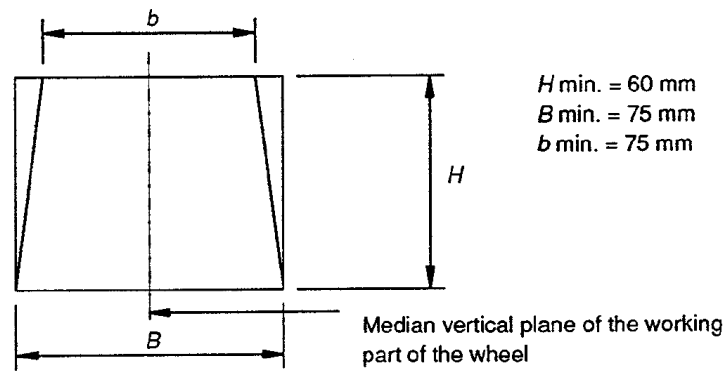
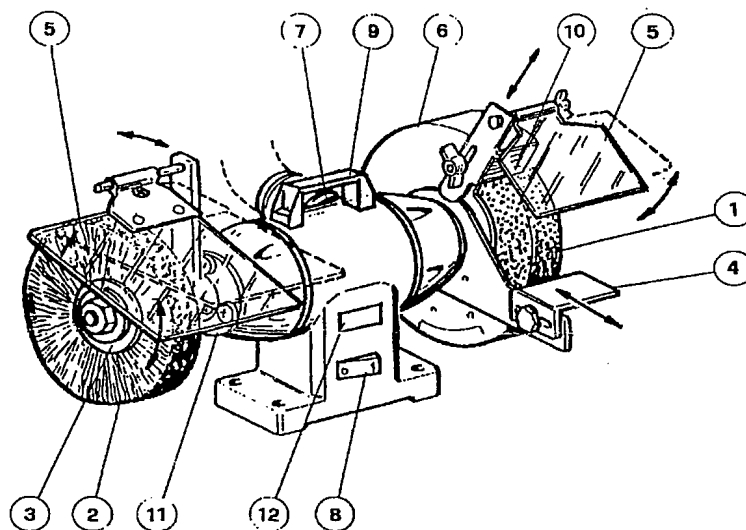

Figure 106 – Transparent screen



- | | |
|------------------------------------|----------------------|
| 1 - straight-sided grinding wheel | 7 - nozzle for dust |
| 2 - brush | 8 - on/off device |
| 3 - flange | 9 - handle |
| 4 - work rest | 10 - spark arrestor |
| 5 - transparent screen | 11 - cup shaft guard |
| 6 - guard for straight-sided wheel | 12 - marking plate |

Figure 107 – Combined bench grinder

NOTE The drawings are given as a guide only.

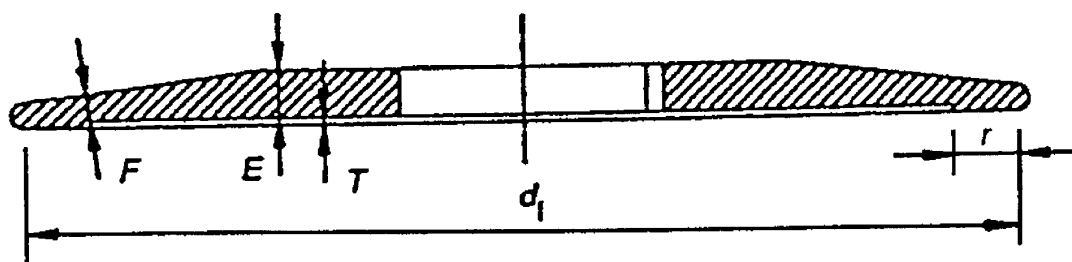

Dimensions in millimetres

- D Wheel nominal diameter
- d_f Minimal external diameter of flanges
- r Minimal width of contact surface
- E Minimal flange thickness on flat surface
- F Minimal flange thickness on inclined surface
- T Minimal depth of recess

Figure 108 – Flange dimensions for wheel

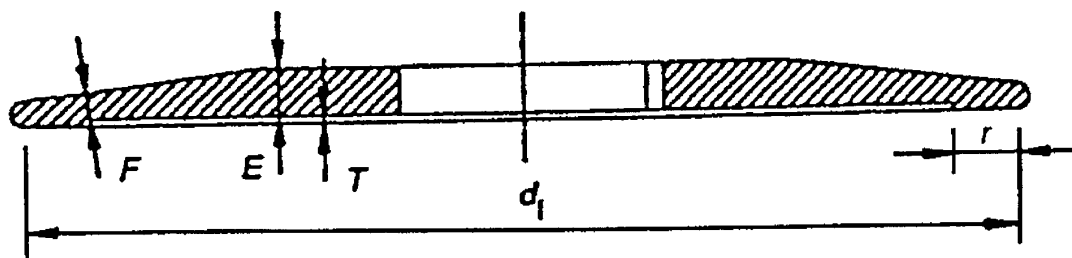

Dimensions in millimetres

- D Brush nominal diameter
- d_f Minimal external diameter of flanges
- r Minimal width of contact surface
- E Minimal flange thickness on flat surface
- F Minimal flange thickness on inclined surface
- T Minimal depth of recess

Figure 109 – Flange dimensions for brush

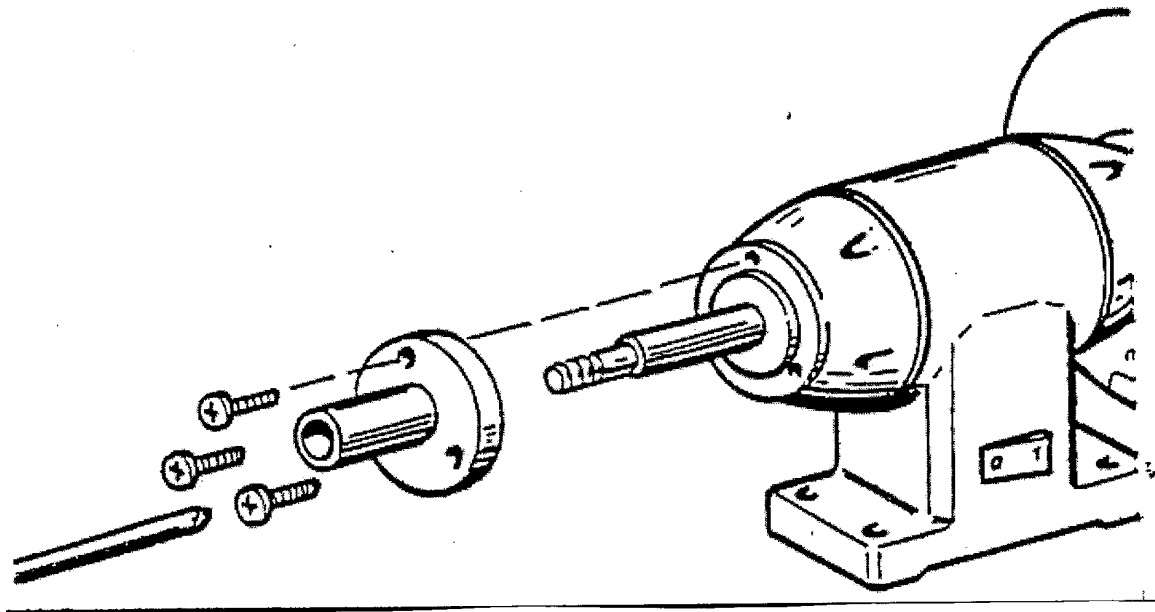
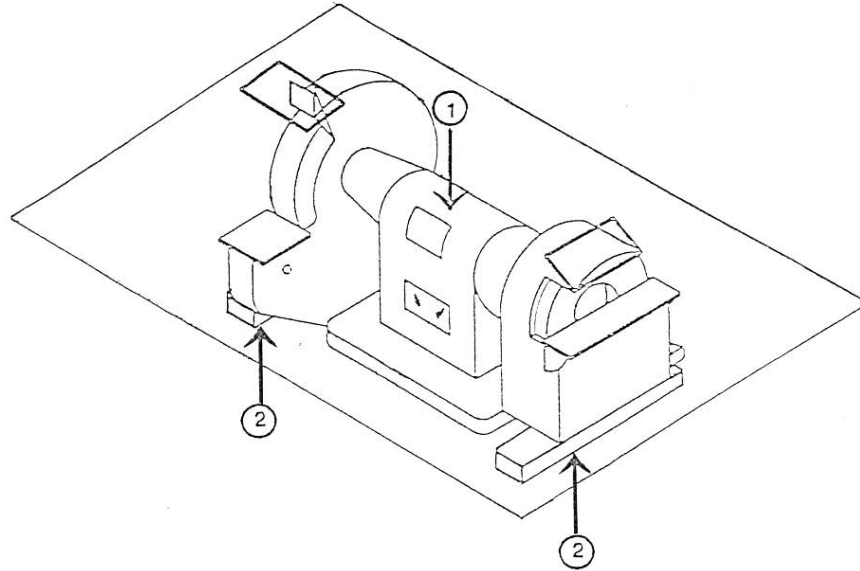

Figure 110



- 1 Vertical load equal to the weight of the grinder
- 2 Support to the guard

Figure Z101 – Mechanical strength

Annexes

The annexes of part 1 are applicable except as follows:

Annex A
(normative)

Normative references

Addition:

<u>Publication</u>	<u>Date</u>	<u>Title</u>
EN 10025	1990	Hot rolled products of non-alloy structural steels - Technical delivery conditions
EN 10130	1991	Cold rolled low carbon steel flat product for cold forming - Technical delivery conditions
EN 12413	1999	Safety requirements for bonded abrasive products
ISO 1052	1982	Steels for general engineering purposes
ISO 3522	1984	Cast aluminium alloys - Chemical composition and mechanical
ISO 3574	1999	Cold-reduced carbon steel sheet of commercial and drawing qualities
ISO 3755	1991	Cast carbon steels for general engineering purposes
ISO 4997	1999	Cold-reduced steel sheet of structural quality
ISO 6361	Series	Wrought aluminium and aluminium alloy sheets, strips and plates
ISO 6316	2000	Hot-rolled steel strip of structural quality

BSI — British Standards Institution

BSI is the independent national body responsible for preparing British Standards. It presents the UK view on standards in Europe and at the international level. It is incorporated by Royal Charter.

Revisions

British Standards are updated by amendment or revision. Users of British Standards should make sure that they possess the latest amendments or editions.

It is the constant aim of BSI to improve the quality of our products and services. We would be grateful if anyone finding an inaccuracy or ambiguity while using this British Standard would inform the Secretary of the technical committee responsible, the identity of which can be found on the inside front cover. Tel: +44 (0)20 8996 9000. Fax: +44 (0)20 8996 7400.

BSI offers members an individual updating service called PLUS which ensures that subscribers automatically receive the latest editions of standards.

Buying standards

Orders for all BSI, international and foreign standards publications should be addressed to Customer Services. Tel: +44 (0)20 8996 9001. Fax: +44 (0)20 8996 7001. Email: orders@bsi-global.com. Standards are also available from the BSI website at <http://www.bsi-global.com>.

In response to orders for international standards, it is BSI policy to supply the BSI implementation of those that have been published as British Standards, unless otherwise requested.

Information on standards

BSI provides a wide range of information on national, European and international standards through its Library and its Technical Help to Exporters Service. Various BSI electronic information services are also available which give details on all its products and services. Contact the Information Centre. Tel: +44 (0)20 8996 7111. Fax: +44 (0)20 8996 7048. Email: info@bsi-global.com.

Subscribing members of BSI are kept up to date with standards developments and receive substantial discounts on the purchase price of standards. For details of these and other benefits contact Membership Administration. Tel: +44 (0)20 8996 7002. Fax: +44 (0)20 8996 7001. Email: membership@bsi-global.com.

Information regarding online access to British Standards via British Standards Online can be found at <http://www.bsi-global.com/bsonline>.

Further information about BSI is available on the BSI website at <http://www.bsi-global.com>.

Copyright

Copyright subsists in all BSI publications. BSI also holds the copyright, in the UK, of the publications of the international standardization bodies. Except as permitted under the Copyright, Designs and Patents Act 1988 no extract may be reproduced, stored in a retrieval system or transmitted in any form or by any means – electronic, photocopying, recording or otherwise – without prior written permission from BSI.

This does not preclude the free use, in the course of implementing the standard, of necessary details such as symbols, and size, type or grade designations. If these details are to be used for any other purpose than implementation then the prior written permission of BSI must be obtained.

Details and advice can be obtained from the Copyright & Licensing Manager. Tel: +44 (0)20 8996 7070. Fax: +44 (0)20 8996 7553. Email: copyright@bsi-global.com.

BSI
389 Chiswick High Road
London
W4 4AL